

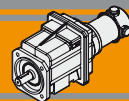

Neodymium

Motoriduttori CC ad ingranaggi cilindrici DC helical in-line gearmotors





Indice	Index	Pag. Page
Caratteristiche tecniche	<i>Technical features</i>	C2
Designazione	<i>Classification</i>	C3
Sensi di rotazione	<i>Direction of rotation</i>	C3
Lubrificazione	<i>Lubrication</i>	C3
Simbologia	<i>Symbols</i>	C4
Carichi radiali	<i>Radial loads</i>	C4
Dati tecnici per servizio S2	<i>Technical data for S2 duty</i>	C5
Motori applicabili	<i>IEC Motor adapters</i>	C6
Dimensioni	<i>Dimensions</i>	C7

Questa sezione annulla e sostituisce ogni precedente edizione o revisione. Qualora questa sezione non Vi sia giunta in distribuzione controllata, l'aggiornamento dei dati ivi contenuto non è assicurato. **In tal caso la versione più aggiornata è disponibile sul nostro sito internet www.transtecno.com**

This section replaces any previous edition and revision. If you obtained this catalogue other than through controlled distribution channels, the most up to date content is not guaranteed. In this case the latest version is available on our web site www.transtecno.com

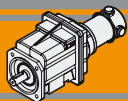

Caratteristiche tecniche

Le caratteristiche principali dei motoriduttori CC ad ingranaggi cilindrici a magneti permanenti in neodimio NDCMG sono:

- Alimentazione in bassa tensione 12/24 Vcc
- Possibilità di montaggio encoder
- Potenze motore disponibili da 160 a 250W S2
- Magneti in Neodimio
- Carcasse dei riduttori in pressofusione di alluminio
- Lubrificazione permanente con olio sintetico
- Ingranaggi sempre rettificati

Technical features

The main features of NDCMG neodymium permanent magnets DC helical in-line gearmotors range are:

- Low voltage power supply 12/24 Vdc
- Suitable for encoder assembly
- Motor power ratings available from 160 to 250W S2
- Neodymium magnets
- Die-cast aluminum housing
- Permanent synthetic oil long-life lubrication
- Ground helical gears

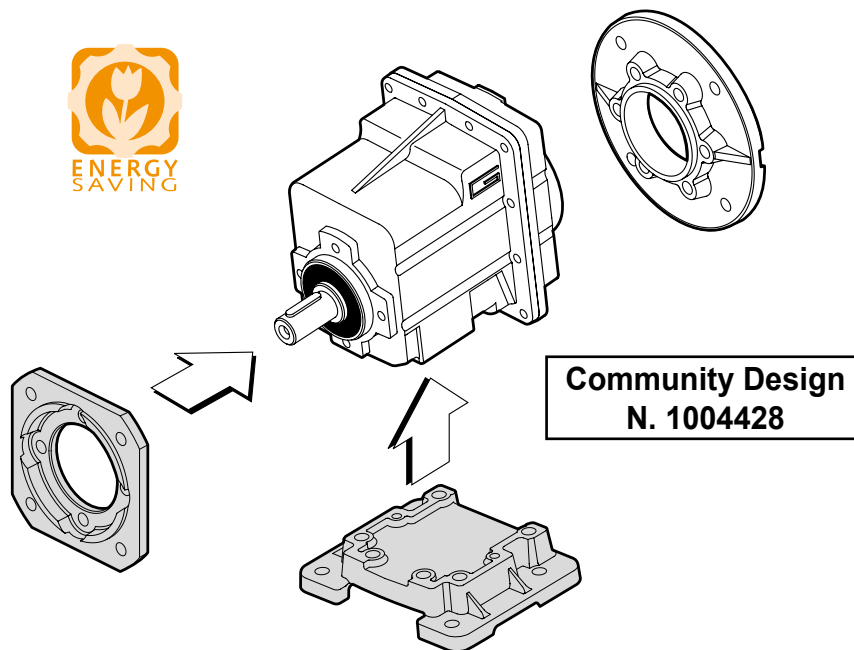

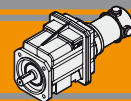

Designazione

Classification

NDCMG

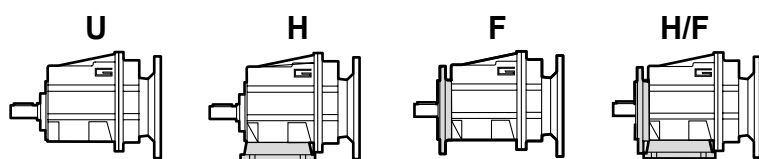

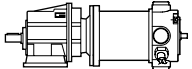
MOTORIDUTTORE / GEARMOTOR						
NDCMG	120/002		U	8.99	D20	240
Tipo Type	Grandezza Size		Versione Version	Rapporto Ratio	Albero uscita Output shaft	Versione motore Motor version
NDCMG 	120/002 120/012 120/013 120/022 120/023 120/033 120/043	180/002 180/012 180/013 180/022 180/023 180/033 180/043	U... H... F... H.../F...	vedi tabelle see tables	vedi tabelle see tables	120 240

Sensi di rotazione

Direction of rotation

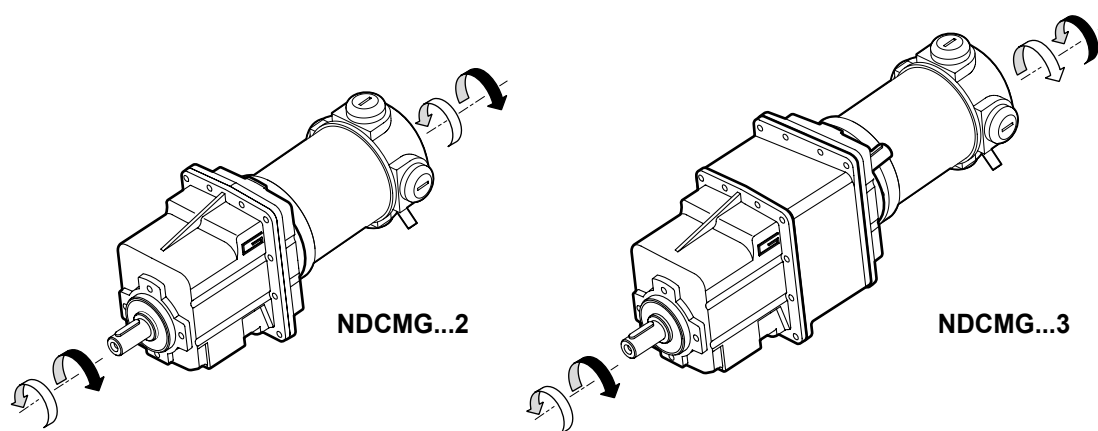

Lubrificazione

Lubrication

Tutti i riduttori nelle taglie 002 sono forniti completi di lubrificante sintetico viscosità 320, pertanto possono essere installati in qualunque posizione di montaggio e non necessitano di manutenzione.

Permanent synthetic oil long-life lubrication (viscosity grade 320) makes it possible to use sizes 002 in all mounting positions; for this reason they can be installed in any assembly position and do not require maintenance.

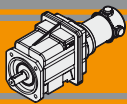

Simbologia

Symbols

n_1	[min ⁻¹]	Velocità in ingresso / <i>Input speed</i>
n_2	[min ⁻¹]	Velocità in uscita / <i>Output speed</i>
i		Rapporto di riduzione / <i>Ratio</i>
P_1	[kW]	Potenza in entrata / <i>Input power</i>
M_2	[Nm]	Coppia nominale in uscita in funzione di P_1 / <i>Output torque referred to P_1</i>
sf		Fattore di servizio / <i>Service factor</i>
R_2	[N]	Carico radiale ammissibile in uscita / <i>Permitted output radial load</i>
A_2	[N]	Carico assiale ammissibile in uscita / <i>Permitted output axial load</i>

Carichi radiali

Radial loads

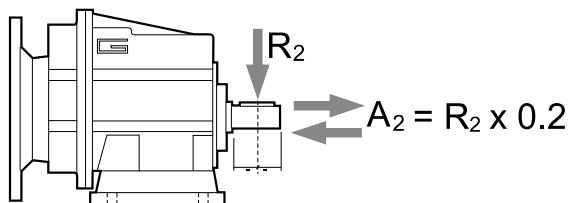

n_2 [min ⁻¹]	R_2 [N]				
	CMG 00	CMG 01	CMG 02	CMG 03	CMG 04
700	416	764	1529	1987	2379
600	437	805	1609	2092	2504
500	465	855	1710	2223	2661
400	501	921	1842	2395	2866
250	586	1077	2154	2801	3353
180	653	1323	2554	3321	3897
150	748	1406	2714	3529	4244
120	806	1631	3467	3801	4572
100	958	1842	3684	4507	5234
80	1032	1984	3969	5042	5991
60	1136	2184	4368	5549	6594
40	1300	2500	5000	6500	8000
10	1300	2500	5000	6500	8000

Quando il carico radiale risultante non è applicato sulla mezzeria dell'albero occorre calcolare quello effettivo con la seguente formula:

When the resulting radial load is not applied on the centre line of the shaft it is necessary to calculate the effective load with the following formula:

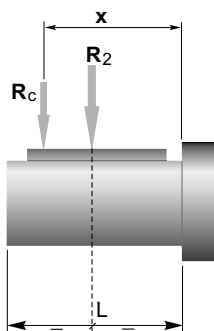

	CMG 00	CMG 01	CMG 02	CMG 03	CMG 04
a	73	104	117	132	150
b	53	84	92	102	115
R_{2MAX}	1300	2500	5000	6500	8000

$$R_c = \frac{R_2 \cdot a}{(b + x)} \leq R_{2MAX}$$

a, b = valori riportati nella tabella
 a, b = values given in the table

$$R \leq R_c$$

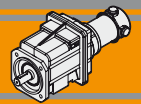

Dati tecnici per servizio S2

Technical data for S2 duty

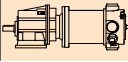
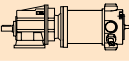
P_1 [W]	n_2 [min ⁻¹]	M_2 [Nm]	sf	i		Versione motore Motor version	P_1 [W]	n_2 [min ⁻¹]	M_2 [Nm]	sf	i		Versione motore Motor version
160							250						
(3000 min ⁻¹)	596	2.5	12.6	5.03	120/002	120/240	(3000 min ⁻¹)	596	3.8	8.1	5.03	180/002	120/240
	492	3.0	10.4	6.10				492	4.7	6.7	6.10		
	401	3.7	8.5	7.49				401	5.7	5.4	7.49		
	334	4.4	8.9	8.99				334	6.9	5.7	8.99		
	295	5.0	7.9	10.16				295	7.8	5.0	10.16		
	249	5.9	6.6	12.07				249	9.2	4.2	12.07		
	224	6.6	8.4	13.40				224	10	5.4	13.40		
	198	7.4	7.4	15.14				198	12	4.8	15.14		
	165	8.9	6.2	18.17				165	14	4.0	18.17		
	139	11	5.2	21.58				139	17	3.3	21.58		
	128	12	4.8	23.51				128	18	3.1	23.51		
	120	12	4.5	25.10				120	19	2.9	25.10		
	111	13	4.2	27.08				111	21	2.7	27.08		
	92	16	3.5	32.49				92	25	2.2	32.49		
	71	21	2.7	42.04				71	32	1.7	42.04		
	67	22	2.5	44.89				67	34	1.6	44.89		
	61	24	2.3	48.86				61	37	1.5	48.86		
	54	27	2.0	55.10									
	85	17	5.4	35.47	120/012	120/240		127	18	5.2	23.56	180/012	120/240
	65	22	4.2	45.89				101	23	4.2	29.56		
	61	24	3.9	49.00				85	27	3.5	35.47		
	56	26	3.6	53.33				65	35	2.7	45.89		
	50	29	3.2	60.15				61	37	2.5	49.00		
								56	41	2.3	53.33		
								50	46	2.0	60.15		
	47	30	3.1	63.22	120/013	120/240		47	47	2.0	63.22	180/013	120/240
	40	36	2.6	75.08				40	56	1.7	75.08		
	34	43	2.2	89.17				34	67	1.4	89.17		
	27	54	1.7	113.05				27	85	1.1	113.05		
	22	64	1.5	134.27				22	100	0.9	134.27		
	17	83	1.1	173.72				17	130	0.7	173.72		
	15	97	1.0	202.16				15	134	0.7	202.16		
	11	125	0.8	261.57				11	134	0.7	261.57		
	10	134	0.7	304.00				10	134	0.7	304.00		
	7.6	134	0.7	393.33				7.6	134	0.7	393.33		
	6.8	134	0.7	443.59				6.8	134	0.7	443.59		
	33	43	3.6	90.29	120/023	120/240		65	35	4.4	46.46	180/022	120/240
	26	55	2.8	114.46				60	38	4.1	49.61		
	22	65	2.4	135.95				56	41	3.8	54.00		
	17	84	1.9	175.89				49	47	3.4	60.90		
	15	98	1.6	204.69									
	11	127	1.2	264.84									
	10	147	1.1	307.80									
	7.5	191	0.8	398.25									
	6.7	215	0.7	449.14									
	17	83	2.8	174.26	120/033	120/240							
	13	108	2.2	225.47									
	11	125	1.9	262.05									
	9.2	156	1.5	325.79									
	7.9	181	1.3	378.64									
	7.0	204	1.1	427.03									
	11	125	3.1	262.05	120/043	120/240							
	9.2	156	2.5	325.79									
	7.9	181	2.2	378.64									
	7.0	204	1.9	427.03									

NDCMG

N.B.
Verificare sempre che la coppia M2 utilizzata non ecceda il valore indicato nelle caselle in grigio
N.B.
Please check that the output torque M2 does not exceed the value in the grey areas

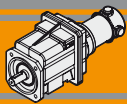

Dati tecnici per servizio S2

Technical data for S2 duty

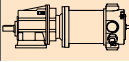
P_1 [W]	n_2 [min ⁻¹]	M_2 [Nm]	sf	i		Versione motore Motor version
250						
(3000 min ⁻¹)	47	48	3.3	64.01	180/023	120/240
	39	57	2.7	76.02		
	33	68	2.3	90.29		
	26	86	1.8	114.46		
	22	102	1.5	135.95		
	17	132	1.2	175.89		
	15	153	1.0	204.69		
	11	198	0.8	264.84		
	10	223	0.7	307.80		
	7.5	223	0.7	398.25		
	6.7	223	0.7	449.14		

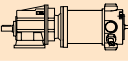
P_1 [W]	n_2 [min ⁻¹]	M_2 [Nm]	sf	i		Versione motore Motor version
250						
(3000 min ⁻¹)	41	54	4.3	72.83	180/033	120/240
	31	73	3.2	97.45		
	26	87	2.7	115.74		
	21	105	2.2	140.81		
	17	130	1.8	174.26		
	13	169	1.4	225.47		
	11	196	1.2	262.05		
	9.2	244	1.0	325.79		
	7.9	283	0.8	378.64		
	7.0	319	0.7	427.03		
	21	105	3.7	140.81	180/043	120/240
	17	130	3.0	174.26		
	13	169	2.3	225.47		
	11	196	2.0	262.05		
	9.2	244	1.6	325.79		
	7.9	283	1.4	378.64		
	7.0	319	1.2	427.03		

N.B.
Verificare sempre che la coppia M_2 utilizzata non ecceda il valore indicato nelle caselle in grigio
N.B.
Please check that the output torque M_2 does not exceed the value in the grey areas

Motori applicabili

IEC Motor adapters

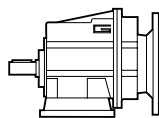
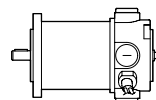

		ND	
		120.120 120.240	180.120 180.240
CMG	002	5.03 - 55.10	
	012	3.82 - 60.15	
	013	63.22 - 443.59	
	022	3.66 - 60.9	
	023	64.01 - 449.14	
	033	72.83 - 427.03	
	043	72.83 - 427.03	

5.03 - 55.10

Rapporti di riduzione i
Ratio i

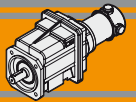

Dimensioni

Dimensions

NDCMG..U

NDCMG120/002 U
NDCMG180/002 U

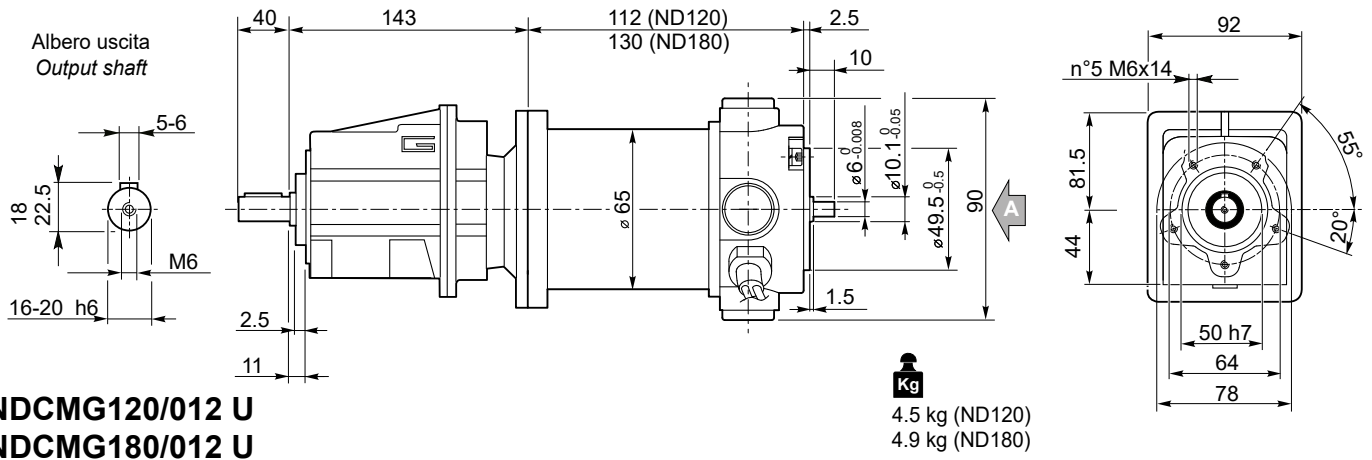

NDCMG120/012 U
NDCMG180/012 U

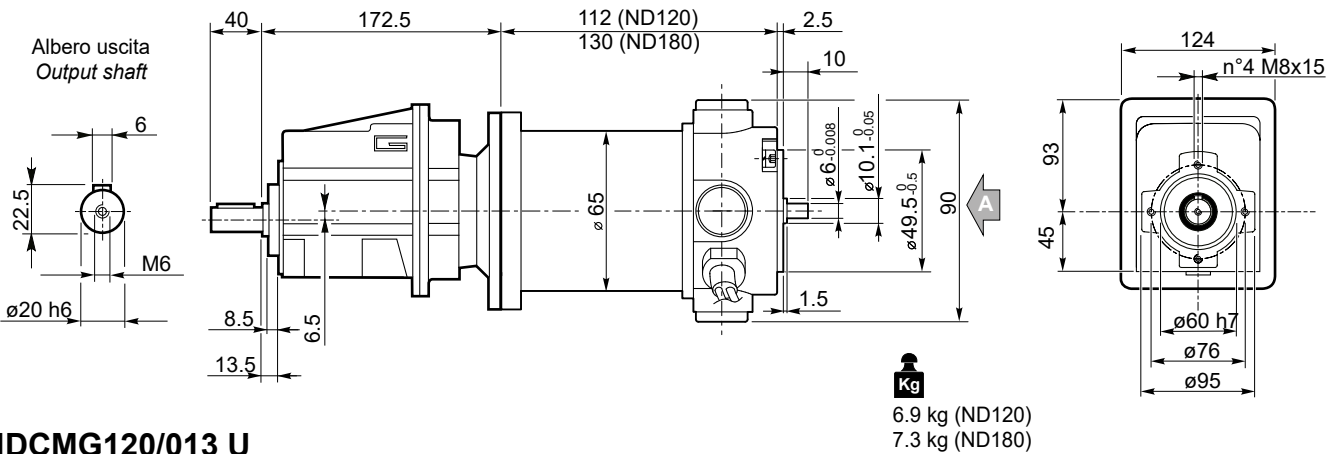

NDCMG120/013 U
NDCMG180/013 U

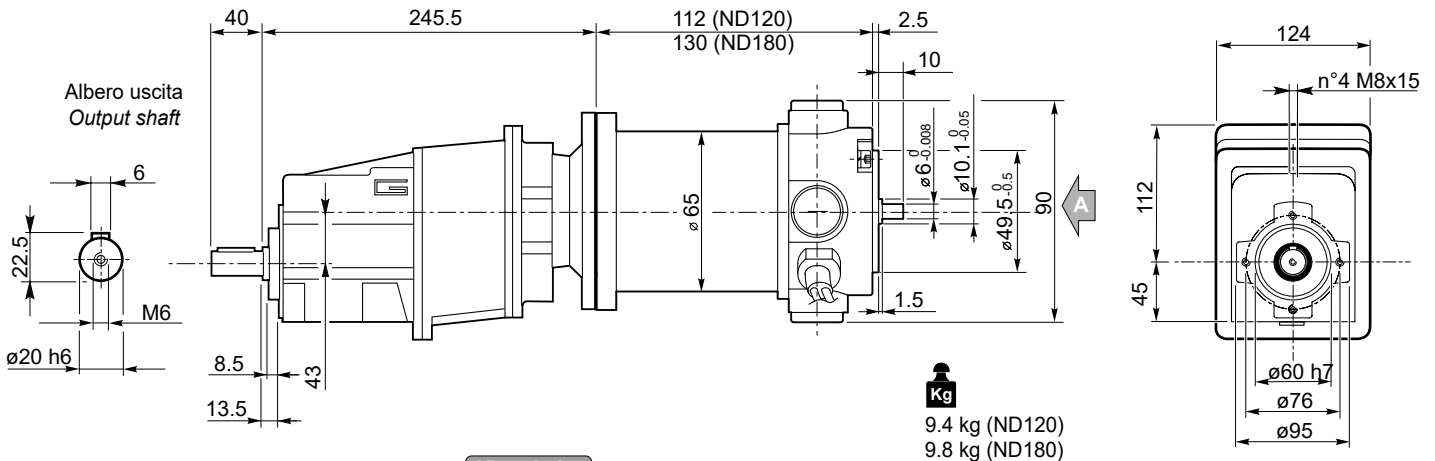

Vista da A
View from A

NDCMG...H



NDCMG...F



NDCMG...H/F

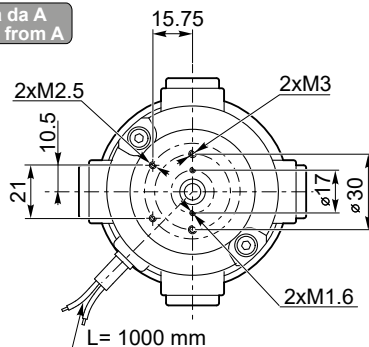

Freno / Brake

B9

Encoder

B9

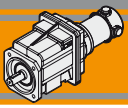

Dimensioni

Dimensions

NDCMG..U

NDCMG120/022 U NDCMG180/022 U

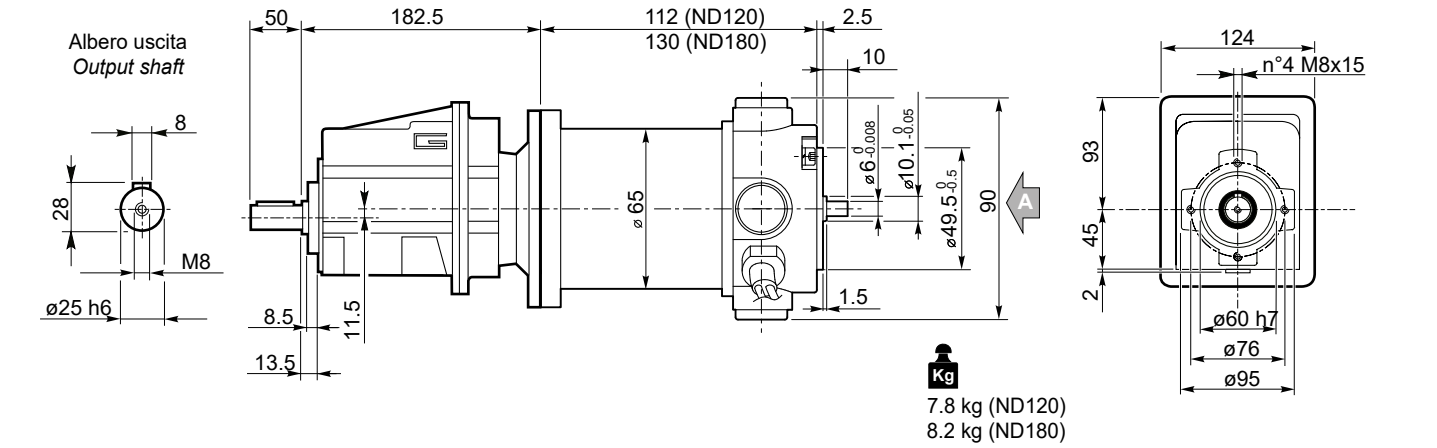

NDCMG120/023U NDCMG180/023 U

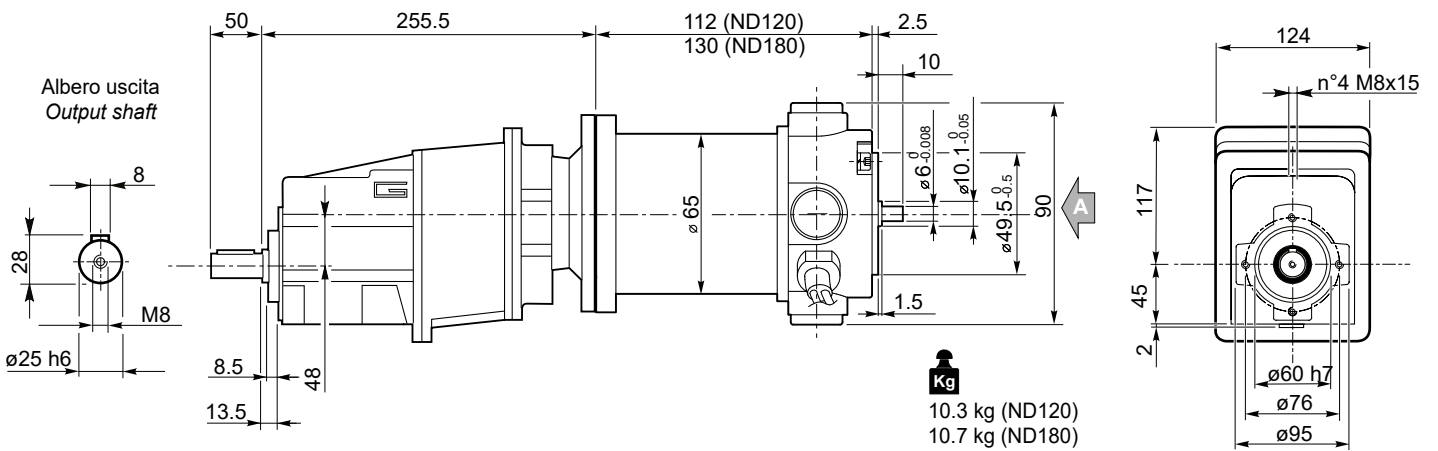

Vista da A
View from A

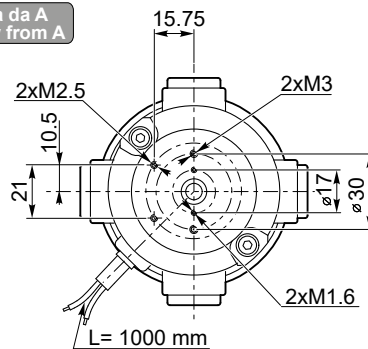

NDCMG...H



NDCMG...F



NDCMG...H/F



Freno / Brake



Encoder



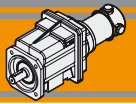

Dimensioni

Dimensions

NDCMG..U

NDCMG120/033 U
NDCMG180/033 U

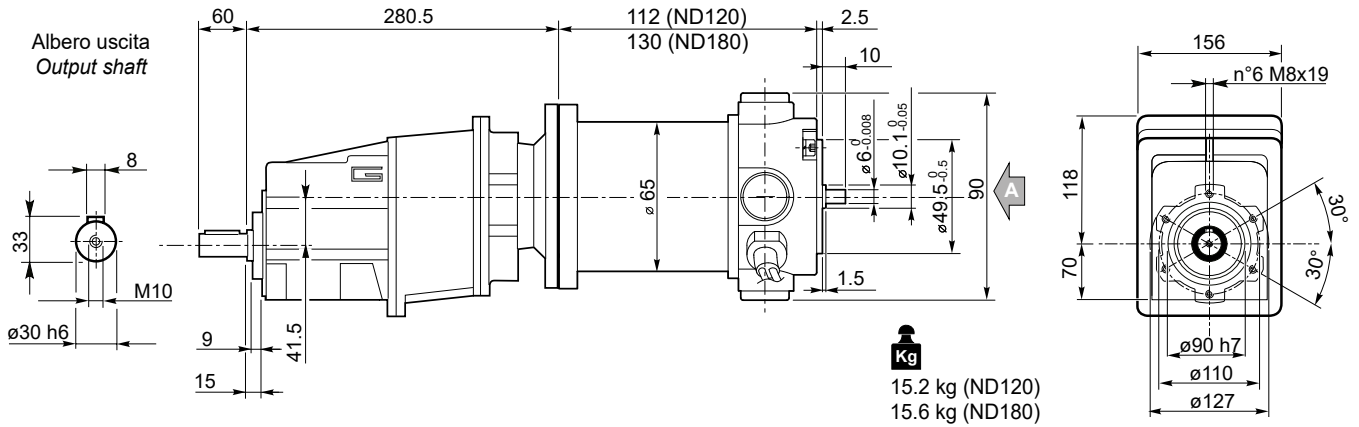

NDCMG120/043 U
NDCMG180/043 U

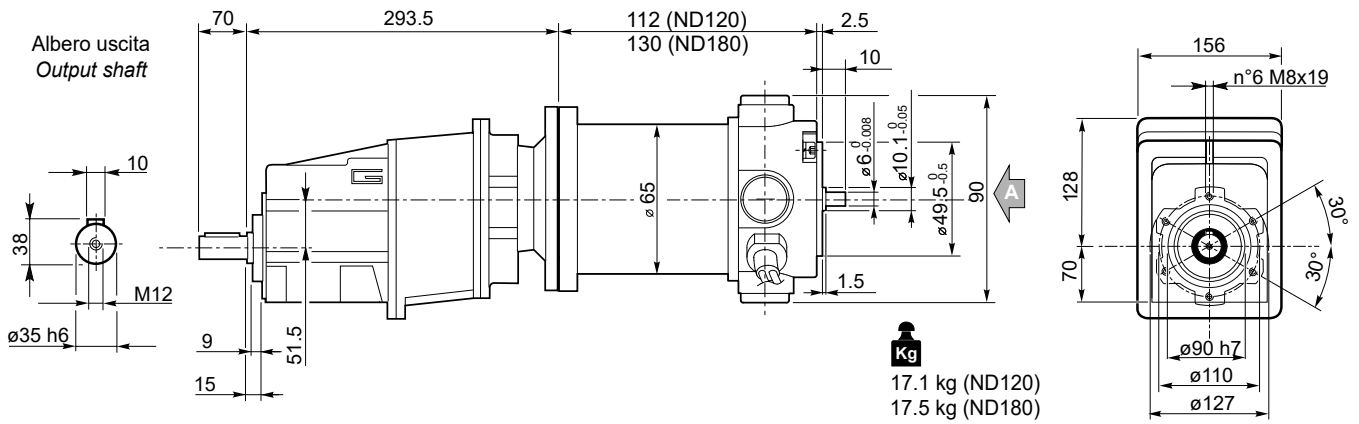

NDCMG...H



NDCMG...F



NDCMG...H/F



Vista da A
View from A

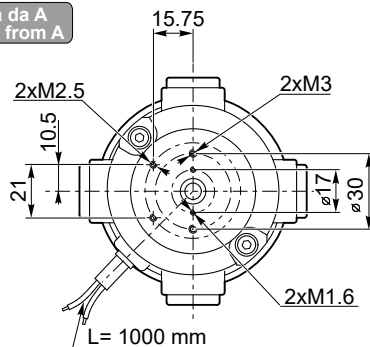

Freno / Brake



Encoder



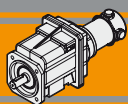

Dimensioni

Dimensions

NDCMG..H

NDCMG..2 H..

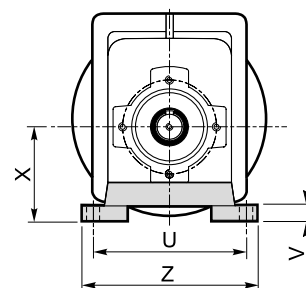
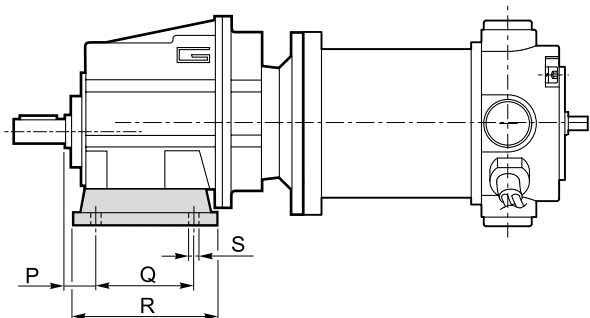

NDCMG..3 H..

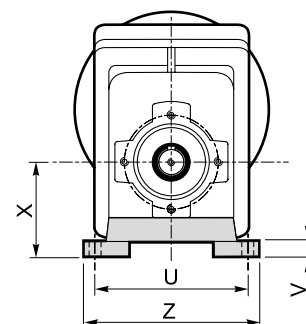
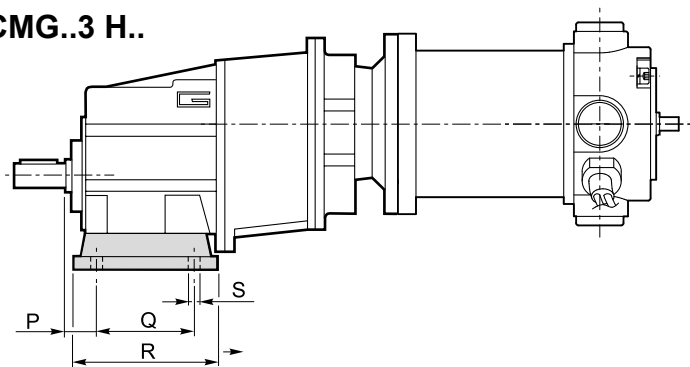

Versione H / H Version

CMG	P	Q	R	S	U	V	X	Z	Piede / Foot	
									Tipo / Type	Peso / Weight [kg]
002	18	60	80	9	100	10	60	120	H60	0.2
	18	80	104	9	110 - 120	10	75	145	H75	0.3
	18	50 - 87	110	9	110	10	85	135	H85	0.4
012 013	20	85	108	9	115	12	65	139	H65	0.7
	18	80	118	9	110	12	75	140	H75	1.0
	25	85	120	9	120	12	80	140	H80	1.1
	18	50 - 87	118	9	110	12	85	130	H85	1.2
	25	130	154	9	110	12	90	135	H90	1.5
	18	60 - 107.5	135	11	130	12	100	155	H100	1.7
022 023	20	85	108	9	115	12	65	139	H65	0.7
	18	80	118	9	110	12	75	140	H75	1.0
	25	85	120	9	120	12	80	140	H80	1.1
	18	50 - 87	118	9	110	12	85	130	H85	1.2
	25	130	154	9	110	12	90	135	H90	1.5
	18	60 - 107.5	135	11	130	12	100	155	H100	1.7
033	30	105	136	14	160	14	95	194	H95	1.5
	30	100	150	11	150	14	110	185	H110	1.9
	18	70			160					
	30	165	195	14	135	14	115	170	H115	2.2
	35	110	160	14	170	14	120	210	H120	2.6
043	30	105	136	14	160	14	95	194	H95	1.5
	30	100	150	11	150	14	110	185	H110	1.9
	18	70			160					
	30	165	195	14	135	14	115	170	H115	2.2
	35	110	160	14	170	14	120	210	H120	2.6

Preferenziale / Preferred

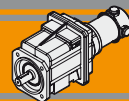

Dimensioni

Dimensions

NDCMG..F

NDCMG..2 F..

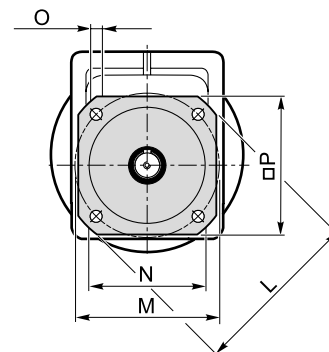
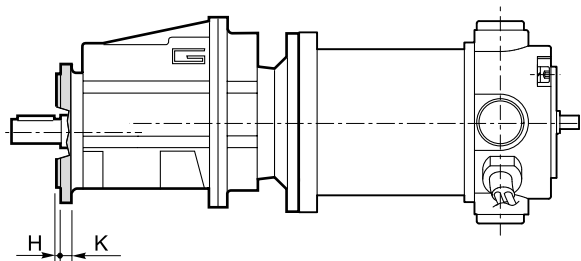

NDCMG..3 F..

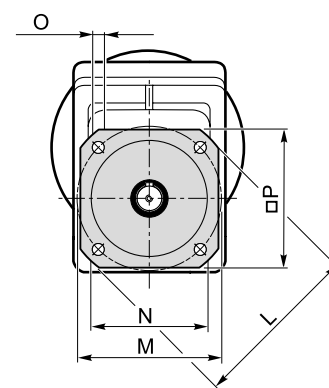
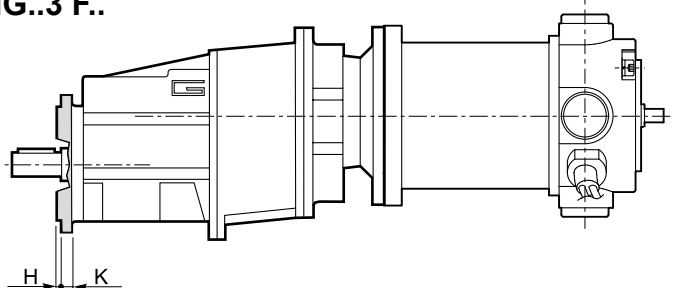

NDCMG

Versione F / F Version

CMG	H	K	L	M	N f7	O	P	Flangia / Flange	
								Tipo / Type	Peso / Weight [kg]
002	3.5	7	105	85	70	6.5	90	F105	0.1
	3.5	8	120	100	80	7	100	F120	0.2
	3.5	8	140	115	95	9	115	F140	0.2
012 013	3	9	120	100	80	9	106	F120	0.5
	3.5	9	140	115	95	9	115	F140	0.8
	3.5	9	160	130	110	9	126	F160	1.1
022 023	3.5	11	200	165	130	11	165	F200	1.8
	3	9	120	100	80	9	106	F120	0.5
	3.5	9	140	115	95	9	115	F140	0.8
	3.5	9	160	130	110	9	126	F160	1.1
033	3.5	11	160	130	110	9	140	F160	1.0
	3.5	11	200	165	130	11	165	F200	1.8
	4	13	250	215	180	14	215	F250	2.9
043	3.5	11	160	130	110	9	140	F160	1.0
	3.5	11	200	165	130	11	165	F200	1.8
	4	13	250	215	180	14	215	F250	2.9

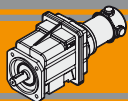

Dimensioni

Dimensions

Versione H / H Version											Combinazioni possibili H/F Possible combinations H/F						
CMG	P	Q	R	S	U	V	X	Z	Piede / Foot		F105	F120	F140	F160	F200	F250	F300
									Tipo / Type	Peso / Weight [kg]							
002	18	60	80	9	100	10	60	120	H60	0.2	•	•	•				
	18	80	104	9	110 - 120	10	75	145	H75	0.3	•	•	•				
	18	50 - 87	110	9	110	10	85	135	H85	0.4	•	•	•				
012 013	20	85	108	9	115	12	65	139	H65	0.7		•	•				
	18	80	118	9	110	12	75	140	H75	1.0		•	•	•			
	25	85	120	9	120	12	80	140	H80	1.1		•	•	•			
	18	50 - 87	118	9	110	12	85	130	H85	1.2		•	•	•			
	25	130	154	9	110	12	90	135	H90	1.5		•	•	•	•		
	18	60 - 107.5	135	11	130	12	100	155	H100	1.7		•	•	•	•		
022 023	20	85	108	9	115	12	65	139	H65	0.7		•	•				
	18	80	118	9	110	12	75	140	H75	1.0		•	•	•			
	25	85	120	9	120	12	80	140	H80	1.1		•	•	•			
	18	50 - 87	118	9	110	12	85	130	H85	1.2		•	•	•			
	25	130	154	9	110	12	90	135	H90	1.5		•	•	•	•		
	18	60 - 107.5	135	11	130	12	100	155	H100	1.7		•	•	•	•		
033	30	105	136	14	160	14	95	194	H95	1.5				•	•		
	30	100	150	11	150	14	110	185	H110	1.9				•	•		
	18	70			160												
	30	165	195	14	135	14	115	170	H115	2.2				•	•	•	
	35	110	160	14	170	14	120	210	H120	2.6				•	•	•	
043	30	105	136	14	160	14	95	194	H95	1.5				•	•		
	30	100	150	11	150	14	110	185	H110	1.9				•	•		
	18	70			160												
	30	165	195	14	135	14	115	170	H115	2.2				•	•	•	
	35	110	160	14	170	14	120	210	H120	2.6				•	•	•	

Preferenziale / Preferred

• Combinazioni possibili H/F / Possible combinations H/F

Versione F / F Version									
CMG	H	K	L	M	N f7	O	P	Flangia / Flange	
								Tipo / Type	Peso / Weight [kg]
002	3.5	7	105	85	70	6.5	90	F105	0.1
	3.5	8	120	100	80	7	100	F120	0.2
	3.5	8	140	115	95	9	115	F140	0.2
012 013	3	9	120	100	80	9	106	F120	0.5
	3.5	9	140	115	95	9	115	F140	0.8
	3.5	9	160	130	110	9	126	F160	1.1
	3.5	11	200	165	130	11	165	F200	1.8
022 023	3	9	120	100	80	9	106	F120	0.5
	3.5	9	140	115	95	9	115	F140	0.8
	3.5	9	160	130	110	9	126	F160	1.1
	3.5	11	200	165	130	11	165	F200	1.8
033	3.5	11	160	130	110	9	140	F160	1.0
	3.5	11	200	165	130	11	165	F200	1.8
	4	13	250	215	150	14	215	F250	2.9
043	3.5	11	160	130	110	9	140	F160	1.0
	3.5	11	200	165	130	11	165	F200	1.8
	4	13	250	215	150	14	215	F250	2.9

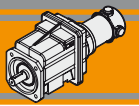

Dimensioni

Dimensions

NDCMG..H../F..

NDCMG..2 H../F..

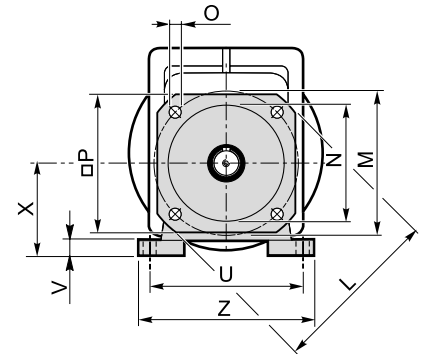
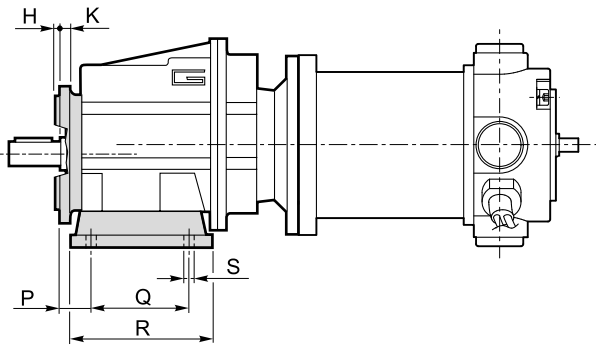

NDCMG..3 H../F..

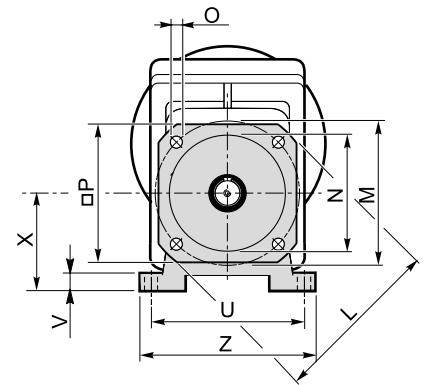
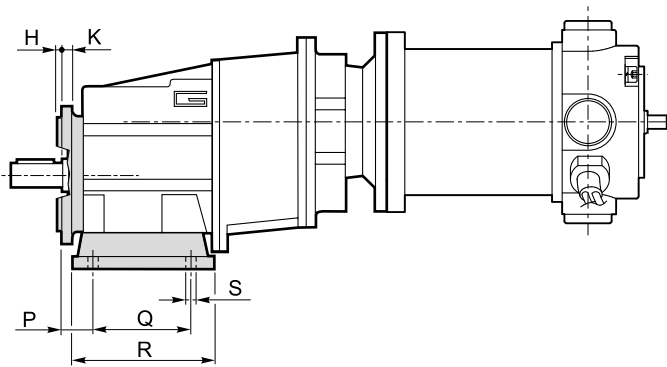

NDCMG



MA TRANSTECNO S.A.P.I. DE C.V.
 Av. Mundial # 176, Parque Industrial
 JM Apodaca, Nuevo León,
 C.P. 66600
 MÉXICO
 T +52 8113340920
 info@transtecno.com.mx
 www.transtecno.com.mx



TRANSTECNO SRL
 Via Caduti di Sabbiano, 11/D-E
 40011 Anzola dell'Emilia (BO)
 ITALY
 T+39 051 64 25 811
 F +39 051 73 49 43
 sales@transtecno.com
 www.transtecno.com



**HANGZHOU TRANSTECNO POWER
 TRANSMISSIONS CO LTD**
 No.4 Xiuyan Road Fengdu Industry Zone
 Pingyao Town Yuhang District
 Hangzhou City, Zhejiang Province
 311115 – CHINA
 T +86 571 86 92 02 60
 F +86 571 86 92 18 10
 info-china@transtecno.com
 www.transtecno.cn



TRANSTECNO U.S.A. LLC
 5440 S.W. 156th Place Miami,
 FL 33185 - USA
 Tel: +1 (305) 220-4423
 Fax: +1 (305) 220-5945
 usaoffice@transtecno.com



TRANSTECNO B.V.
 Ind. terrein Wieken/Vinkenhof
 De Stuwdam,43
 3815 KM Amersfoort - NETHERLANDS
 Tel: +31(0) 33 45 19 505
 Fax: +31(0) 33 45 19 506
 info@transtecno.nl
 www.transtecno.nl



SALES OFFICE INDIA
 A/10, Anagha, S.N. Road, Mulund (W) Mumbai
 400080 - INDIA
 Tel: +91 9820614698
 Fax-Italy: +39 051 73 49 43
 indiaoffice@transtecno.com



SALES OFFICE BRAZIL
 Rua Dr. Freire Alemão 155 / 402 - CEP. 90450-060
 Auxiliadora Porto Alegre RS - BRAZIL
 Tel: +55 51 3251 5447
 Fax: +55 51 3251 5447
 Mobile: +55 51 811 45 962
 braziloffice@transtecno.com
 www.transtecno.com.br



TRANSTECNO AANDRIJFTECHNIEK B.V.
 De Stuwdam 43
 3815 KM Amersfoort - NETHERLANDS
 Tel: +31 (0) 33 20 4 7 006
 info@transtecnoaandrijftechnik.nl
 www.transtecnoaandrijftechnik.nl



SALES OFFICE SOUTH KOREA
 D-304 Songdo BRC Smart Valley 30, Songdomirae-ro,
 Yeonsu-gu, Incheon, 406-840 - KOREA
 Tel: +82 70 8288 2107
 Fax: +82 32 815 2107
 Mobile: +82 10 5094 2107
 koreaoffice@transtecno.com



**TRANSTECNO IBÉRICA
 THE MODULAR GEARMOTOR, S.A.**
 C/Enginy, 2 Nave 6 - 08850 Gavà (Barcelona) - SPAIN
 Tel: +34 931 598 950
 info@transtecno.es
 www.transtecno.es



SALES OFFICE OCEANIA
 44 Northview drive, Sunshine west 3020
 Victoria - AUSTRALIA
 Ph +61 03 9312 4722
 Fax +61 03 9312 4714
 Mobile: +61 0438060997
 oceaniaoffice@transtecno.com
 www.transtecno.com.au



SALES OFFICE FRANCE
 Tel: +33 (0) 6 85 12 09 87
 Fax-Italy: +39 051 73 49 43
 franceoffice@transtecno.com
 www.transtecno.fr

TRANSTECNO[®]
 the modular gearmotor
 www.transtecno.com