

TRANSTECNO[®]
the modular gearmotor

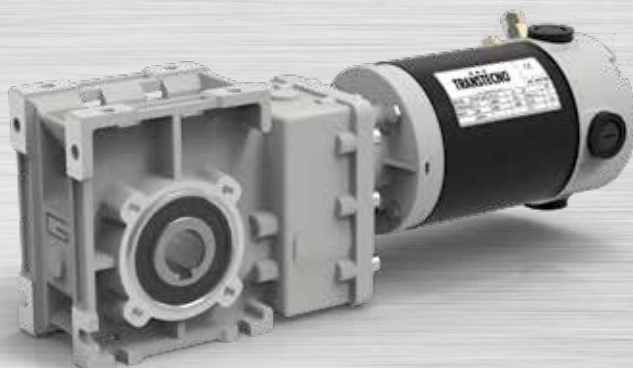
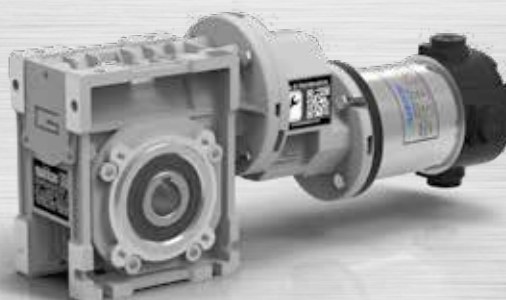
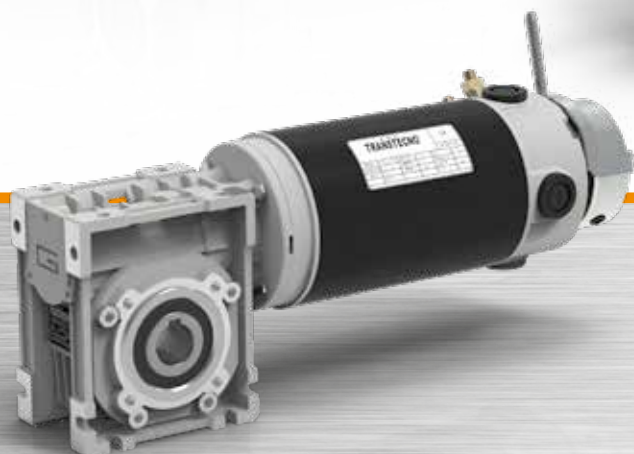

Indice

Index

Pag.
Page

Neodymium

A Introduzione **Introduction** **A1**



B Motori elettrici CC **DC Electric motors** **B1**
ND

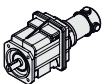

C Motoriduttori CC **DC Helical in-line** **C1**
ad ingranaggi cilindrici **gearmotors**
NDCMG

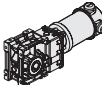

D Motoriduttori CC ad assi ortogonali **DC Helical bevel gearmotors** **D1**
NDCMB

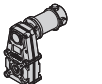

E Motoriduttori CC pendolari **DC Helical parallel gearmotors** **E1**
NDFT



F Motoriduttori CC a vite senza fine **DC Wormgearmotors** **F1**
NDCM



G Motoriduttori CC a vite senza fine **DC Pre stage** **G1**
con precoppia **wormgearmotors**
NDCMP

Ferrite



H Motori elettrici CC **DC Electric motors** **H1**
EC

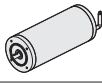

I Motori elettrici CC in IP66 **IP66 DC Electric motors** **I1**
EC IP66

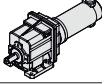

L Motoriduttori CC ad ingranaggi **DC Helical in-line gearmotors** **L1**
cilindrici **ECMG**

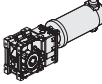

M Motoriduttori CC ad assi ortogonali **DC Helical bevel gearmotors** **M1**
ECMB



N Motoriduttori CC pendolari **DC Helical parallel gearmotors** **N1**
ECFT



O Motoriduttori CC a vite senza fine **DC Wormgearmotors** **O1**
ECM

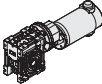

P Motoriduttori CC a vite senza fine **DC Pre stage** **P1**
con precoppia **wormgearmotors**
ECMP



Q Motoriduttori CC a vite senza fine **DC Double reduction wormgearmotors** **Q1**
combinati **ECMM**



R Azionamenti per motori CC **DC Motor controls** **R1**
PLN

Questo catalogo annulla e sostituisce ogni precedente edizione o revisione. Ci riserviamo inoltre il diritto di apportare modifiche senza preavviso. La versione più aggiornata è disponibile sul sito www.transtecno.com

This catalogue supersedes any previous edition and revision. We reserve the right to implement modifications without notice. The most updated version is available on our website www.transtecno.com

Indice	Index	Pag. Page
Generalità	<i>General information</i>	A2
Velocità entrata	<i>Input speed</i>	A2
Rapporto di riduzione	<i>Gear ratio</i>	A2
Velocità in uscita	<i>Output speed</i>	A2
Coppia richiesta	<i>Requested torque</i>	A2
Coppia nominale	<i>Nominal torque</i>	A3
Coppia trasmessa	<i>Output torque</i>	A3
Rendimento del riduttore a vite senza fine	<i>Worm gearbox efficiency</i>	A3
Reversibilità e irreversibilità	<i>Reversibility and irreversibility</i>	A4
Potenza in entrata	<i>Input power</i>	A4
Fattore di servizio	<i>Service factor</i>	A5
Carico radiale	<i>Radial load</i>	A6
Carico assiale	<i>Axial load</i>	A6
Scelta dei motoriduttori	<i>Selecting the gearmotors</i>	A6
Installazione e verifiche	<i>Installation and inspection</i>	A8
Applicazioni critiche	<i>Critical applications</i>	A8

Questa sezione annulla e sostituisce ogni precedente edizione o revisione. Qualora questa sezione non Vi sia giunta in distribuzione controllata, l'aggiornamento dei dati ivi contenuto non è assicurato. **In tal caso la versione più aggiornata è disponibile sul nostro sito internet www.transtecno.com**

*This section replaces any previous edition and revision. If you obtained this catalogue other than through controlled distribution channels, the most up to date content is not guaranteed. **In this case the latest version is available on our web site www.transtecno.com***

Generalità

Per avere una migliore comprensione degli argomenti e dei dati esposti in questo catalogo proponiamo la simbologia utilizzata corredandola delle informazioni di base per giungere ad una corretta selezione dei motoriduttori e variatori.

General information

Information in this manual is provided with symbols in order to understand the subject matter and data. These symbols are intended to aid the user in selecting the right gearmotors and variators.

Velocità entrata

n_1 [min⁻¹]

Input speed

Rappresenta la velocità riferita al tipo di motorizzazione prescelta ed è applicata in entrata al riduttore.

This is the input speed at the gearbox related to the type of drive unit selected.

Per selezioni a velocità diverse da quelle riportate consultare il ns. Servizio Tecnico.

When different speeds are required, contact our Technical Service.

Rapporto di riduzione

i

Gear ratio

È una grandezza adimensionale ed è in funzione del numero dei denti degli ingranaggi interni al riduttore.

This value is strictly related to the size and number of teeth gears inside the gearbox.

Nei riduttori a vite senza fine si ottiene dividendo il numero di denti della corona per il numero dei filetti (Z) della vite senza fine.

This value is obtained in wormgearboxes by dividing the number of wheel teeth by the number of starts (Z) of the worm.

Dai dati di catalogo si può ottenere con la relazione:

From the data given in the catalogue, the value can be calculated using the following formula:

$$i = \frac{n_1}{n_2}$$

Velocità in uscita

n_2 [min⁻¹]

Output speed

È la velocità risultante sull'asse di uscita del riduttore e viene ricavata dalla relazione precedente:

This is the gearbox output speed calculated using the formula given above:

$$n_2 = \frac{n_1}{i}$$

Coppia richiesta

Mr_2 [Nm]

Requested torque

È la coppia richiesta dall'applicazione ed è indispensabile per la selezione di una motorizzazione.

This is the torque needed for the application and must be known when selecting a drive system. It can either be provided by the user or calculated according to the application data (if provided).

Essa può essere comunicata dall'utente oppure calcolata in base ai dati di applicazione (se forniti).

Coppia nominale

Mn_2 [Nm]

Nominal torque

Rappresenta la coppia in uscita trasmissibile dal riduttore in base alla velocità in entrata n_1 e al rapporto di riduzione i . Essa è calcolata in base ad un servizio con carico continuo uniforme corrispondente ad un fattore di servizio uguale a 1. Questo valore non è riportato nel presente catalogo ma può essere ricavato approssimativamente con la seguente relazione fra M_2 (coppia trasmessa) e sf (fattore di servizio):

This is the output torque that can be transmitted by the gearbox according to input speed n_1 and gear ratio i . It is calculated based on service with a continuous steady load corresponding to a service factor equal to 1. This value is not given in the catalogue but can be calculated approximately with the following formula between M_2 (output torque) and sf (service factor):

$$Mn_2 = M_2 \cdot sf$$

Coppia trasmessa

M_2 [Nm]

Output torque

È la coppia trasmessa in uscita al riduttore. Dipende dalla potenza P_1 del motore installato, dal numero di giri in uscita n_2 e dal rendimento dinamico Rd e può essere calcolata con la relazione:

This is the gearbox's output torque. It is strictly related to power P_1 of the motor installed, output rpm n_2 and dynamic efficiency Rd . It can be calculated with the following formula:

$$M_2 = \frac{9550 \cdot P_1 \cdot Rd}{n_2}$$

oppure:
or:

$$M_2 = \frac{9550 \cdot P_2}{n_2}$$

dove:
where:

$$P_2 = P_1 \cdot Rd$$

Rendimento del riduttore a vite senza fine

$Rd; Rs$

Worm gearbox efficiency

I calcoli delle prestazioni sono stati effettuati in base al rendimento dinamico Rd dei riduttori (valore ottimale che si raggiunge nel funzionamento a regime dopo rodaggio).

Efficiency is calculated based on dynamic efficiency Rd of the gearboxes (optimal value reached when running at normal speed after the break in period).

Nei riduttori combinati, il rendimento complessivo è dato dal prodotto dei rendimenti dei due riduttori, considerando però che nel secondo riduttore il rendimento dovrà essere valutato in base alla ridotta velocità in entrata ottenuta dividendo n_1 per il rapporto i del primo riduttore.

In combination gearboxes, overall efficiency is obtained from the combined efficiency of the two gearboxes. However, keep in mind that efficiency of the second gearbox should be determined according to the reduced input speed obtained by dividing n_1 by ratio i of the first gearbox.

È opportuno considerare che nei riduttori a vite senza fine si ha anche un valore di rendimento statico Rs , presente in fase di avviamento, che declassa sensibilmente la coppia risultante per cui influenza in modo determinante la scelta di motorizzazioni destinate ad applicazioni intermittenti (es. sollevamenti).

It is important to remember that wormgearboxes also have static efficiency value Rs present at start-up. This value notably reduces the resulting torque. As a result, it must be taken into consideration when selecting drive systems for intermittent operations (e.g. lifting) as it is a determinant factor.

Il valore dei rendimenti dinamico e statico dei riduttori a vite senza fine sono riportati nella tabella a pag. N4.

Dynamic and static efficiency of wormgearboxes are given in the table on page N4.

Nei riduttori ad ingranaggi CMG e CMB il rendimento medio è del 94%.

On helical gearboxes CMG and CMB the average efficiency is 94%.

Nei motovariatori il rendimento assume un valore di 0.85 alla velocità massima e decresce fino a 0.7 alla velocità minima.

Efficiency is 0.85 at the highest speed decreasing to 0.7 at the lowest speed in motovariators.

Reversibilità e irreversibilità

Reversibility and irreversibility

La diretta conseguenza del rendimento (statico e dinamico) è la reversibilità del riduttore a vite senza fine che consiste nella possibilità di fare ruotare l'albero entrata tramite l'applicazione di una torsione più o meno accentuata sull'albero uscita.

L'impossibilità o la difficoltà ad effettuare l'azione sopra descritta, determina il grado di reversibilità (o irreversibilità) di un riduttore.

Questa caratteristica, molto significativa nei riduttori a vite senza fine, è influenzata da molteplici fattori quali angolo d'elica (quindi rapporto di trasmissione), lubrificazione, temperatura, finitura superficiale della vite senza fine, presenza di vibrazioni, ecc.

In applicazioni dove sono presenti delle traslazioni è necessario garantire una elevata reversibilità onde evitare che le inerzie delle masse in movimento possano determinare punte di carico inammissibili sugli organi di trasmissione.

In applicazioni dove è richiesto un non ritorno del carico (es. sollevamenti o nastri trasportatori inclinati) in assenza di un freno motore è necessario scegliere un riduttore caratterizzato da un elevato grado di irreversibilità.

Desideriamo comunque evidenziare che la garanzia assoluta di non ritorno è data esclusivamente dall'installazione di un motore autofrenante o di un altro dispositivo frenante esterno.

La tabella sottostante riporta a titolo puramente indicativo i vari gradi di reversibilità/irreversibilità nei riduttori a vite senza fine in funzione del rendimento dinamico Rd e statico Rs.

Reversibility of the wormgearbox is the direct consequence of efficiency (static and dynamic). This determines whether or not the input shaft can be rotated by applying a certain torque on the output shaft.

Whether or not this can be done and how difficult it actually is to do determine the degree of reversibility (or irreversibility) of a gearbox.

This feature, quite significant in wormgearboxes, is affected by numerous factors including the helix angle (therefore drive ratio), lubrication, temperature, surface finish of the worm, vibrations, etc...

In applications that include translations, high reversibility must be guaranteed to prevent inertia of the moving parts from creating unacceptable load peaks on the drive parts.

In applications that require non-return of the load (e.g. lifting or inclined conveyor belts) a gearbox with high irreversibility must be chosen when a motor-brake unit is not present.

However, we would like to point out that non-return can be totally assured only by installing a self-braking motor or other external braking device.

The table below is provided for reference purposes only. It contains the various degrees of reversibility/irreversibility of wormgearboxes in relation to dynamic Rd and static Rs efficiency.

Rd	Reversibilità e irreversibilità dinamica	Dynamic reversibility and irreversibility
> 0.6	Reversibilità dinamica	Dynamic reversibility
0.5 - 0.6	Reversibilità dinamica incerta	Uncertain dynamic reversibility
0.4 - 0.5	Buona irreversibilità dinamica	Good dynamic irreversibility
<0.4	Irreversibilità dinamica	Dynamic irreversibility
Rs	Reversibilità e irreversibilità statica	Static reversibility and irreversibility
> 0.55	Reversibilità statica	Static reversibility
0.5 - 0.55	Reversibilità statica incerta	Uncertain static reversibility
<0.5	Irreversibilità statica	Static irreversibility

Potenza in entrata

P_1 [kW]

Input power

È la potenza motore applicata in entrata al riduttore e riferita alla velocità n_1 .

Può essere calcolata come segue:

This is the power applied by the motor at the gearbox input in reference to speed n_1 .

It can be calculated with the following formula:

$$P_1 = \frac{M_2 \cdot n_2}{9550 \cdot Rd}$$

Fattore di servizio

sf

Service factor

È una grandezza adimensionale che indica il sovradimensionamento da applicare ad una determinata motorizzazione per garantire la resistenza agli urti e la durata richiesta.

Le tabelle di catalogo offrono una vasta scelta di motorizzazioni con fattori di servizio differenziati che possono soddisfare la maggior parte delle applicazioni più o meno gravose.

Per una corretta interpretazione dei valori del fattore di servizio sf riportati a fianco di ogni selezione proposta, riportiamo nelle tabelle seguenti i valori indicativi attribuiti alle classi di carico A, B, C e alla durata di funzionamento giornaliero h/d e al numero di avviamenti/ora.

Definendo la classe di carico a cui riferire l'applicazione, si ricercherà nella tabella il corrispondente valore di sf da utilizzare nella scelta della motorizzazione più idonea.

This value indicates how a certain drive system is to be over-sized in order to assure the requested service and stand up to shocks.

The tables given in the catalogue offer a wide range of drive systems with different service factors able to satisfy most types of applications. To correctly understand service factor values sf given for each item, approximate values for load classes A, B and C along with the number of hours of daily operation h/d and number of start-ups/hours need to be known.

Once the load class required for the application has been determined, locate corresponding value sf to be used when selecting the most suitable drive system.

A - Uniforme	$fa \leq 0.3$
B - Medio	$fa \leq 3$
C - Forte	$fa \leq 10$

A - Uniform	$fa \leq 0.3$
B - Moderate shocks	$fa \leq 3$
C - Heavy shocks	$fa \leq 10$

$fa = \frac{Je}{Jm}$

- Je (kgm²) momento d'inerzia esterno ridotto all'albero motore.
- Jm (kgm²) momento d'inerzia motore.

Se $fa > 10$ interpellare il ns. Servizio Tecnico.

$fa = \frac{Je}{Jm}$

- Je (kgm²) moment of reduced external inertia at the drive-shaft.
- Jm (kgm²) moment of inertia of motor.

If $fa > 10$ call our Technical Service.

A Classe di carico / Load class
Carico uniforme / Uniform load

sf										
h/d	n. avviamenti/ora / n. start-up/hour									
	2	4	8	16	32	63	125	250	500	
4	0.8	0.8	0.9	0.9	1.0	1.1	1.1	1.2	1.2	
8	1.0	1.0	1.1	1.1	1.3	1.3	1.3	1.3	1.3	
16	1.3	1.3	1.3	1.3	1.5	1.5	1.5	1.5	1.5	
24	1.5	1.5	1.5	1.5	1.8	1.8	1.8	1.8	1.8	

B Classe di carico / Load class
Carico con urti moderati / Moderate shock load

sf										
h/d	n. avviamenti/ora / n. start-up/hour									
	2	4	8	16	32	63	125	250	500	
4	1.0	1.0	1.0	1.0	1.3	1.3	1.3	1.3	1.3	
8	1.3	1.3	1.3	1.3	1.5	1.5	1.5	1.5	1.5	
16	1.5	1.5	1.5	1.5	1.8	1.8	1.8	1.8	1.8	
24	1.8	1.8	1.8	1.8	2.2	2.2	2.2	2.2	2.2	

C Classe di carico / Load class
Carico con urti forti / Heavy shock load

sf										
h/d	n. avviamenti/ora / n. start-up/hour									
	2	4	8	16	32	63	125	250	500	
4	1.3	1.3	1.3	1.3	1.5	1.5	1.5	1.5	1.5	
8	1.5	1.5	1.5	1.5	1.8	1.8	1.8	1.8	1.8	
16	1.8	1.8	1.8	1.8	2.2	2.2	2.2	2.2	2.2	
24	2.2	2.2	2.2	2.2	2.5	2.5	2.5	2.5	2.5	

Esempio applicazione:

Nastro trasportatore attribuibile alla classe di carico B (**carico con urti moderati**) e previsto per una durata di funzionamento giornaliero (h/d) di **16** ore e con **8** avviamenti/ora. Dalla tabella rileviamo **sf = 1.5**

Application example:

Conveyor belt assigned to load class B (**moderate shock load**), to be run **16** hours a day (h/d) with **8** start-ups/hour. The following value is obtained from the table **sf = 1.5**

Carico radiale

R; R₂ [N]

Radial load

L'applicazione sull'albero in uscita del riduttore di pignoni, pulegge, ecc. determina delle forze radiali che debbono necessariamente essere considerate per evitare sollecitazioni eccessive con il rischio di danneggiamenti del riduttore stesso.

Il calcolo del carico radiale esterno R agente sull'albero del riduttore può essere determinato come segue:

Pinions, pulleys, etc applied on the output shaft of the gearboxes create radial forces that must be taken into consideration to avoid excessive stress risking damage to the gearbox itself.

External radial load R that acts on the gearbox shaft can be calculated as follows:

$$R = \frac{2000 \cdot M_2 \cdot kr}{d} \leq R_2$$

dove:

d [mm] diametro primitivo del pignone o della puleggia

kr coefficiente riferito al tipo di trasmissione:

kr = 1.4 ruota per catena

kr = 1.1 ingranaggio

kr = 1.5 - 2.5 puleggia per cinghia a V

where:

d [mm] diameter of the pinion or pulley

kr coefficient in relation to type of transmission:

kr = 1.4 sprocket wheel

kr = 1.1 gear

kr = 1.5 - 2.5 pulley for V belts

È opportuno evidenziare che i valori di R₂ sono riferiti a carichi agenti sulla mezzeria dell'albero lento (considerando l'albero sporgente) per cui il confronto dovrà essere effettuato nelle medesime condizioni.

Keep in mind that values R₂ refer to loads that act on the center-line of the output shaft (considering the shaft protrudes). As a result, the value should be compared under the same conditions.

Carico assiale

A; A₂ [N]

Axial load

A volte, unitamente al carico radiale, può essere presente anche una forza A che agisce assialmente sull'albero uscita; in questo caso considerare che il carico assiale ammissibile A₂ sull'albero è da considerare:

At times, along with the radial load, force A may be present that acts axially on the output shaft. In this case, keep in mind allowable axial load A₂ that can be applied on the shaft is:

$$A_2 = R_2 \cdot 0.2$$

Nel caso in cui il valore del carico assiale A agente sull'albero risultasse superiore ad A₂ contattate il ns. Servizio Tecnico.

If axial load A that acts on the shaft is greater than A₂, contact the Technical Service.

Scelta dei motoriduttori

Selecting the gearmotors

Per la scelta di un motoriduttore è necessario seguire la seguente procedura.

To select the required gearmotor perform the procedure below:

1. Per l'applicazione desiderata ricavare il fattore di servizio sf dalle tabelle a pag. A5 in base alla classe di carico, alle ore di funzionamento giornaliere e al numero di avviamenti orari.

1. Determine the service factor sf for the desired application by referring to the charts given on page A5. This is to be done by considering the class of load, the operational hours/day and the number of start-ups/ hour.

2. Se si conosce la potenza motore P₁ [kW] richiesta, passare al punto 3); se è nota la coppia in uscita M₂ richiesta è necessario calcolare la potenza motore P₁ con la formula:

2. If the required motor power output P₁ [kW] is known, go to item 3); if the required output torque M₂ is known, determine motor output P₁ by using the following formula:

$$P_1 = \frac{M_2 \cdot n_2}{9550 \cdot Rd}$$

dove Rd è il rendimento dinamico e n₂ il numero di giri richiesti in uscita al motoriduttore.

where Rd stands for the dynamic efficiency and n₂ indicates the required output rpm of the gearmotor.

3. Nelle tabelle dei dati tecnici ricercare la motorizzazione in cui sia P_1 maggiore o uguale a P e con riferimento ad una velocità n_2/n_{2max} prossima a quella desiderata, scegliere la motorizzazione in cui il fattore di servizio sf indicato risulta uguale o superiore a quello ricavato al punto 1).

3. Use the specification chart to search for the power unit where P_1 is greater than or equal to P with a speed n_2/n_{2max} that approximates the desired one. Choose a power unit where the indicated service factor sf is equal to or greater than that calculated at point 1).

ECM

P_1 [W]	n_2 [min ⁻¹]	M_2 [Nm]	sf	i		Versione motore Motor version
140						
(3000 min ⁻¹)	600	2.0	5.0	5	ECM100/026	120/240/24E
	400	2.9	3.8	7.5		
	300	3.8	2.9	10		
	200	5.5	2.0	15		
	150	7.1	1.5	20		
	100	10	1.2	30		
	75	12	0.9	40		
	60	14	0.7	50		
	50	13	0.7	60		

Esempio / Example:

Applicazione / Application:

Carrello automatico / Automatic carriage

P_1 : 140 W
 sf : 1.5
 n_2 : 150 min⁻¹

Motorizzazione scelta / Power unit selected:

ECM100/026, $i = 20$, $P_1 = 140$ W, $sf = 1.5$

ECMP

P_1 [W]	n_2 [min ⁻¹]	M_2 [Nm]	sf	i		Versione motore Motor version
250						
(3000 min ⁻¹)	50	35	2.3	60	ECMP180/063/050	120/240/24E
	40	42	1.8	75		
	33	48	2.1	90		
	25	58	1.5	120		
	20	69	1.2	150		
	17	77	1.0	180		
	13	90	0.8	240		

Esempio / Example:

Applicazione / Application:

Carrello automatico / Automatic carriage

M_2 : 58 Nm
 sf : 1.5
 n_2 : 25 min⁻¹

Motorizzazione scelta / Power unit selected:

ECMP180/063/050, $i = 120$, $P_1 = 250$ W, $sf = 1.5$

Installazione e verifiche

Installation and inspection

In fase di installazione del motoriduttore è opportuno verificare che:

- i dati riportati in targhetta corrispondano al prodotto che è stato ordinato;
- le superfici di accoppiamento e gli alberi siano accuratamente puliti e privi di ammaccature;
- le superfici su cui verrà installato il riduttore siano perfettamente piane e sufficientemente rigide;
- l'albero macchina e quello del riduttore siano correttamente allineati;
- siano stati installati sistemi di limitazione della coppia se si prevedono urti o blocchi della macchina durante il funzionamento;
- siano state predisposte le necessarie protezioni antinfortunistiche agli organi rotanti;
- siano state create delle opportune coperture a protezione dagli agenti atmosferici se l'installazione è effettuata all'aperto ed è soggetta alle intemperie;
- l'ambiente di lavoro non sia corrosivo (a meno che tale specifica non sia stata dichiarata in fase di ordine al fine di predisporre il riduttore per questo utilizzo);
- gli eventuali pignoni o pulegge montati sull'albero uscita o entrata del riduttore, siano calettati correttamente in modo tale da non generare carichi radiali e/o assiali superiori a quelli ammissibili;
- su tutti gli accoppiamenti sia stato applicato un adeguato protettivo antiossidante per prevenire eventuali ossidazioni da contatto;
- tutte le viti di fissaggio siano state serrate correttamente.

While installing the gearmotor always make sure that:

- *the specifications stamped on the rating plate match those indicated for the unit actually ordered;*
- *the mating surfaces and the shafts are thoroughly clean and free of dents;*
- *the surfaces where the gearbox are to be mounted on are flat and strong enough;*
- *the machine drive shaft and the gearbox shaft are perfectly aligned;*
- *the required torque limiters have been installed if the machine is likely to produce shocks or blockages during operation;*
- *the rotary parts have been provided with the required safety guards;*
- *adequate weatherproof covering has been provided if the machine is to be installed outdoor;*
- *the working environment is not exposed to corrosive agents (unless this has been indicated while placing the order so that the gearbox assembly can be adequately set up);*
- *the pinions or pulleys on the gearbox input/output shafts are properly fitted in order not to produce radial and/or axial loads that exceed the maximum allowable limits;*
- *all the couplings have been treated with adequate rust preventative in order to avoid oxidation provoked by contact;*
- *all the mounting screws have been securely tightened.*

Applicazioni critiche

Critical applications

In tutti questi casi consultare il Servizio Tecnico

In these cases please contact the Technical Service

- utilizzo come organo di sollevamento;
- utilizzo in posizioni non previste a catalogo;
- utilizzo in ambiente con pressione diversa da quella atmosferica;
- utilizzo in ambiente con temperature $<0^{\circ}\text{C}$ o $>+40^{\circ}\text{C}$
- utilizzo in ambienti esterni
- servizio continuo o altamente intermittente
- utilizzo in applicazioni con forti inerzie

- *used as a hoist;*
- *used in mounting positions not shown in the catalogue;*
- *used in environment pressure other than atmospheric pressure;*
- *used in places with temperature $<0^{\circ}\text{C}$ or $>+40^{\circ}\text{C}$*
- *when used outdoors*
- *continuous or highly intermittent duty*
- *used in applications with high inertia*



Neodymium

Motori elettrici CC
DC electric motors



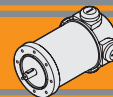

	Indice	Index	Pag. Page
	Caratteristiche tecniche	<i>Technical Features</i>	B2
	Grado di protezione IP	<i>IP enclosures protection indexes</i>	B3
	Classe di isolamento termico	<i>Insulation class</i>	B3
	Tipi di servizio IEC	<i>IEC duty cycle ratings</i>	B3
ND120.120	Caratteristiche	<i>Features</i>	B4
ND120.240	Dimensioni	<i>Dimensions</i>	B4
	Prestazioni	<i>Performances</i>	B5
ND180.120	Caratteristiche	<i>Features</i>	B6
ND180.240	Dimensioni	<i>Dimensions</i>	B6
	Prestazioni	<i>Performances</i>	B7
	Legenda / Glossario dei grafici	<i>Key / Diagram Glossary</i>	B8
	Formule utili	<i>Useful formulas</i>	B8
	Freni	<i>Brakes</i>	B9
	Encoder	<i>Encoder</i>	B9

Questa sezione annulla e sostituisce ogni precedente edizione o revisione. Qualora questa sezione non Vi sia giunta in distribuzione controllata, l'aggiornamento dei dati ivi contenuto non è assicurato. **In tal caso la versione più aggiornata è disponibile sul nostro sito internet www.transtecno.com**

This section replaces any previous edition and revision. If you obtained this catalogue other than through controlled distribution channels, the most up to date content is not guaranteed. In this case the latest version is available on our web site www.transtecno.com

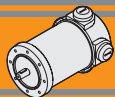

Caratteristiche tecniche

I magneti in Neodimio (NdFeB) fanno parte dei magneti a terre rare e sono attualmente i magneti più potenti in produzione. Dotati di alta forza coercitiva (resistenza alla smagnetizzazione) ed alto valore di saturazione magnetica, sono in grado di immagazzinare moltissima energia magnetica. Pertanto, i motori CC dotati di magneti in Neodimio forniscono alti valori di coppia pur in dimensioni ridotte, grazie all'alta densità di flusso del campo magnetico.

Le caratteristiche principali dei motori elettrici CC a magneti permanenti in neodimio ND sono:

- Campo magnetico generato da magneti permanenti in Neodimio (NdFeB)
- Costruzione tubolare senza ventilazione
- Disponibili in una grandezza diametro 65
- Alimentazione a bassa tensione 12 o 24 Vcc
- Potenza 160W e 250W S2
- Elevata coppia di spunto
- Maggiori coppie e potenze rispetto ai corrispettivi motori a magneti permanenti standard (a parità di dimensioni)
- Predisposizione encoder / freno

Classe di isolamento termico

Gli avvolgimenti del rotore sono soggetti a surriscaldamento, come pure altre parti del motore. Il grado di isolamento indica la massima temperatura ammissibile oltre la quale l'isolante della matassa e l'isolante di tutte le parti soggette ad elevato riscaldamento perde le caratteristiche di buon isolante, con pericolo di danneggiamento del motore.

Servizio

Rappresenta la relazione tra il tempo di lavoro ed il tempo di riposo del motore. Servizio continuo (S1) = funzionamento continuo del motore a pieno carico.

Servizio intermittente (S2, S3, etc...) = periodi alternati di lavoro e di riposo tali da raffreddare il motore. Dato un motore, la potenza espressa per servizio continuo è inferiore a quella per servizio intermittente.

Fattore di forma

Indica quanta componente spuria alternata è presente nella alimentazione CC del motore. Più alto è il fattore ed inferiore è l'efficienza del motore. Alimentatori ad SCR = F.F 1.40. Alimentazione pura da batteria = FF 1 Alimentazione da transistori (modulazione PWM) = FF 1.05.

Qualitativamente l'andamento della coppia (percentuale) rispetto al fattore di forma è indicato nel grafico seguente:

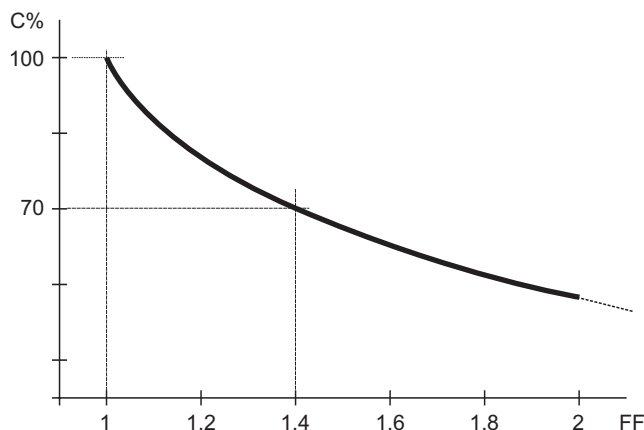

Technical features

Neodymium magnet (NdFeB) is a type of rare-earth magnet and is currently the strongest type of permanent magnets. Due to high coercivity resistance to being demagnetized and high saturation magnetization, they have potential for storing large amounts of magnetic energy. Therefore permanent Neodymium magnets DC motors can provide high torque in compact size due to the high density flux of magnet field.

The main features of ND neodymium permanent magnets DC electric motors range are:

- *Magnetic field generated by Neodymium (NdFeB) permanent magnets*
- *Tubular construction without fan*
- *Available in one size diameter 65*
- *Low voltage power supply 12 or 24 Vdc*
- *Power ratings available 160W and 250W S2*
- *High starting torque*
- *Higher torque and higher power than standard permanent magnet D.C. motors.*
- *Suitable for encoder / brake assembly*

Thermal insulation class

The windings of the rotor can overheat just like other parts of the motor too. The degree of insulation indicates the maximum allowable temperature above which the insulation of the windings, as well as that of all the parts which heat up to a high temperature, loses its insulating properties and the motor therefore risks being damaged.

Duty cycle

This represents the relationship between the time the motor operates and the time it remains stationary. Continuous operation (S1) = the motor operates non-stop under full load.

Intermittent operation (S2, S3, etc.) = alternating periods of work and rest so that the motor can cool down. The output power for continuous operation is lower than that for intermittent operation.

Form factor

It indicates how much spurious alternating current is present in the D.C. motor power supply. The higher the factor, the lower the motor's efficiency. SCR power supplies = F.F 1.40. Battery supply = FF 1 Transistor supply (PWM modulation) = FF 1.05.

The graph below indicates the torque trend (percentage) in relation to the form factor:

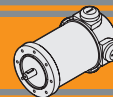

Grado di protezione IP

IP enclosures protection indexes

Indica il grado di isolamento meccanico del corpo motore.

Indicates the degree of mechanical insulation of the motor body.

1^a cifra: protezione alla penetrazione di corpi solidi.

1st figure: indicating level of protection against the penetration of solid bodies.

2^a cifra: protezione contro la penetrazione d'acqua.

2nd figure: indicating degree to which the motor is waterproof.

0	Non protetto / No protection	0	Non protetto / No protection
1	Protetto da corpi solidi superiori a Ø 50 mm. <i>Protected against solid matters (over Ø 50 mm)</i>	1	Protetto contro la caduta verticale di gocce d'acqua. <i>Protected against drops of water falling vertically</i>
2	Protetto da corpi solidi superiori a Ø 12 mm. <i>Protected against solid matters (over Ø 12 mm)</i>	2	Protetto contro la caduta verticale di gocce d'acqua con inclinazione max di 15° <i>Protected against drops of water falling up to 15°</i>
3	Protetto da corpi solidi superiori a Ø 2.5 mm. <i>Protected against solid matters (over Ø 2.5 mm)</i>	3	Protetto contro la pioggia. <i>Rain proof fixture</i>
4	Protetto da corpi solidi superiori a Ø 1 mm. <i>Protected against solid matters (over Ø 1 mm)</i>	4	Protetto contro gli spruzzi. <i>Splash proof fixture</i>
5	Protetto contro la polvere <i>Dust proof</i>	5	Protetto contro getti d'acqua <i>Water jet proof</i>
6	Totalmente protetto contro la polvere <i>Fully dust proof</i>	6	Protetto dalle ondate <i>Wave proof</i>
7	N.A.	7	Protetto contro immersione <i>Watertight immersion fixture.</i>
8	N.A.	8	Protetto contro immersione/sommersione prolungata <i>Watertight immersion fixture for a long time.</i>

Classe di isolamento termico

Insulation class

Classe / Class	Δ t °C Temp. ambiente: 40°C Ambient temperature: 40°C
A	65°C
B	90°C
F	115°C
H	140°C

Tipi di servizio IEC

IEC duty cycle ratings

S1	Servizio continuo. Funzionamento a carico costante per una durata sufficiente al raggiungimento dell'equilibrio termico.	Continuous duty. The motor works at a constant load for enough time to reach temperature equilibrium
S2	Servizio di durata limitata. Funzionamento a carico costante per una durata inferiore a quella necessaria al raggiungimento dell'equilibrio termico, seguito da un periodo di riposo tale da riportare il motore alla temperatura ambiente.	Short time duty. The motor works at a constant load, but not long enough to reach temperature equilibrium, and the rest periods are long enough for the motor to reach ambient temperature.
S3	Servizio periodico intermittente. Sequenze di cicli identici di marcia e di riposo a carico costante, senza raggiungimento dell'equilibrio termico. La corrente di spunto ha effetti trascurabili sul surriscaldamento del motore.	Intermittent periodic duty. Sequential, identical run and rest cycles with constant load. Temperature equilibrium is never reached. Starting current has little effect on temperature rise.
S4	Servizio periodico intermittente con avviamento. Sequenza di cicli di funzionamento identici di avviamento, marcia e riposo a carico costante, senza raggiungimento dell'equilibrio termico. La corrente di spunto ha effetti sul riscaldamento del motore.	Intermittent periodic duty with starting. Sequential identical start, run and rest cycles with constant load. Temperature equilibrium is not reached, but starting current affects temperature rise.
S5	Servizio periodico intermittente con frenatura elettrica. Sequenza di cicli di funzionamento identici di avviamento, marcia a carico costante, frenatura elettrica e riposo, senza raggiungimento dell'equilibrio termico.	Intermittent periodic duty with electric braking. Sequential, identical cycles of starting, running at constant load, electric braking and rest. Temperature equilibrium is not reached.
S6	Servizio periodico ininterrotto con carico intermittente. Sequenza di cicli di lavoro identici con carico costante e senza carico. Non ci sono periodi di riposo.	Continuous operation with intermittent load. Sequential, identical cycles of running with constant load and running with no load. No rest periods.
S7	Servizio periodico ininterrotto con frenatura elettrica. Sequenza di cicli di funzionamento identici di avviamento, marcia a carico costante e frenatura elettrica, senza periodi di riposo.	Continuous operation with electric braking. Sequential, identical cycles of starting, running at constant load and electric braking. No rest periods.
S8	Servizio periodico ininterrotto con variazioni di carico e di velocità. Sequenza di cicli identici di avviamento, marcia a carico costante e velocità definita, seguiti da marcia a carico costante differente e velocità differente dalla precedente. Non ci sono periodi di riposo.	Continuous operation with periodic changes in load and speed. Sequential, identical, duty cycles of start, run at constant load and given speed, then run at other constant loads and speeds. No rest periods.

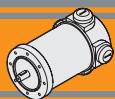

ND120.120 - ND120.240

Caratteristiche

Features

Costruzione	Tubolare, senza ventilazione
Grandezza	Ø 65 mm
Potenza	160 W S2 (120 W S1)
Magneti	4 magneti in terre rare
Supporti	Cuscinetti a sfera
Fori di montaggio	8
Alimentazione	Bassa tensione, 12 o 24 Vcc
Spazzole	N° 4 di composto grafite-rame
Cavo di alimentazione	Lunghezza: 1000 mm
Bisporgenza	Standard

Construction	Tubular, without fan
Size	Ø 65 mm
Power	160 W S2 (120 W S1)
Magnets	4 rare earth magnets
Bearings	Ball bearings
Mounting holes	8
Power supply	Low voltage, 12 or 24 Vdc
Brushes	4 brushes made of graphite/copper composite
Electric cable	Length: 1000 mm
Rear Shaft	Standard

Tipo Type	S	Pn [W]	V [V]	I [A]	IC	FF	Mn [Nm]	n ₁ [min ⁻¹]	IP	Kg
ND120.120	S1	120	12	13.9	F	1	0.38	3000	20	1.6
	S2 20'	160		19			0.51			
ND120.240	S1	120	24	6.9			0.38			
	S2 20'	160		9.0			0.51			

Dimensioni

Dimensions

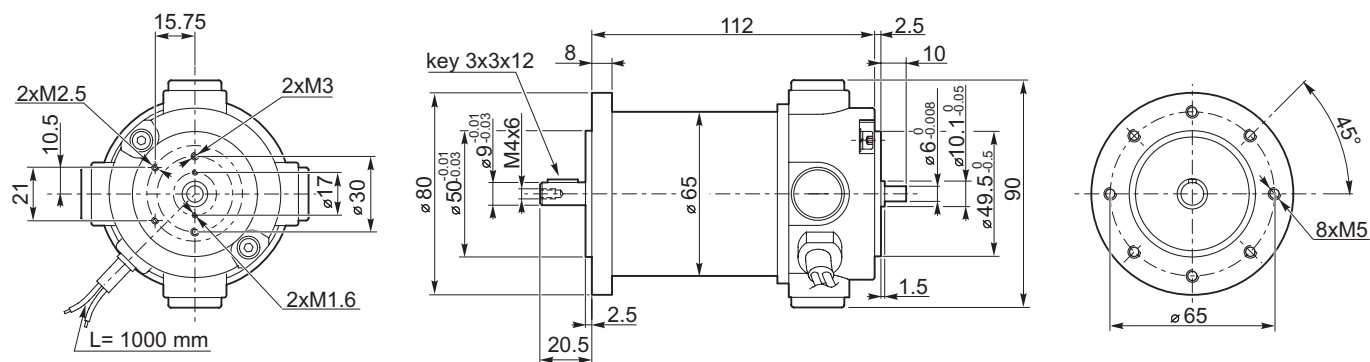

Freno / Brake → B9

Encoder → B9

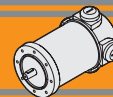

ND120.120 - ND120.240

Prestazioni

Performances

ND120.120

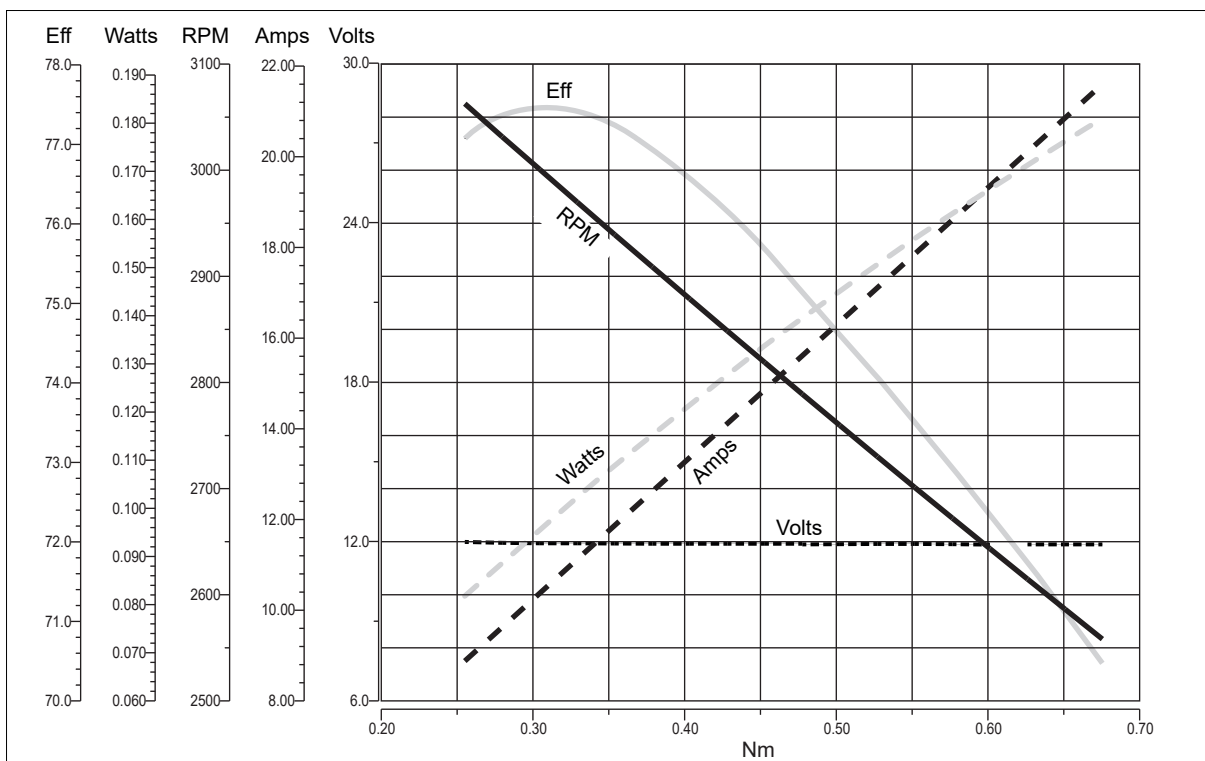

ND120.240

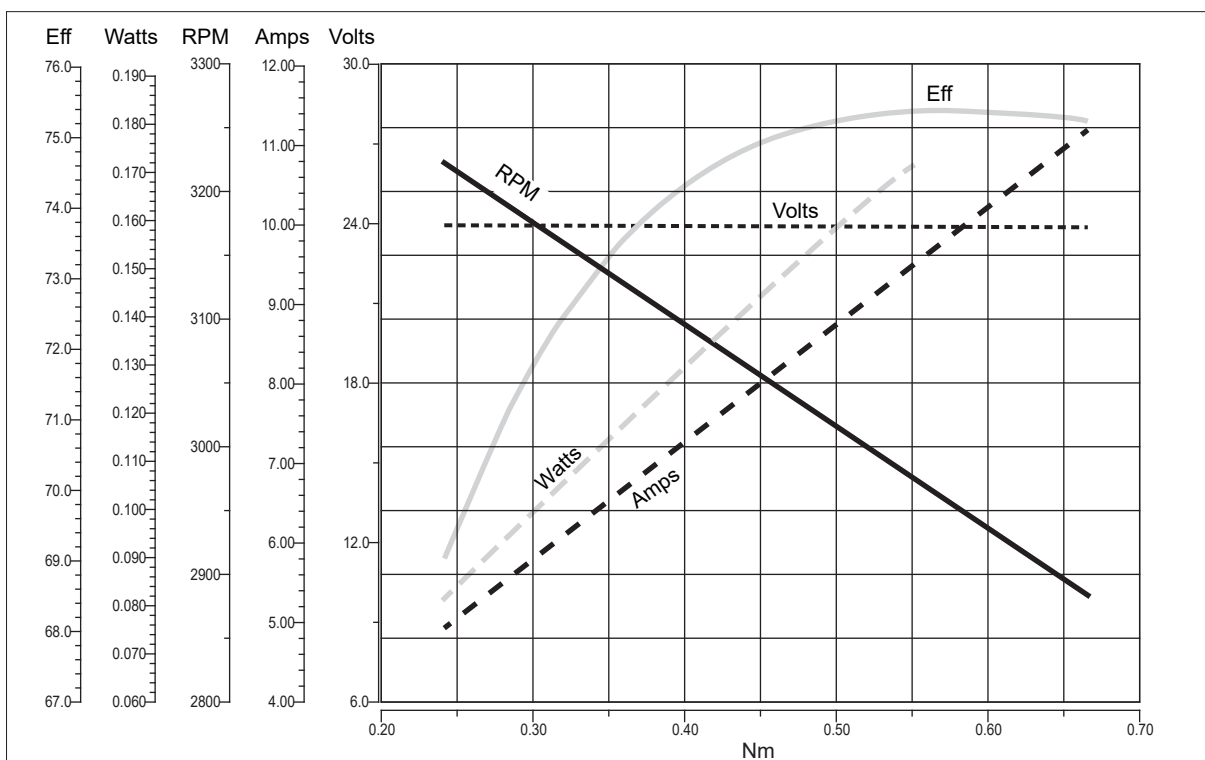

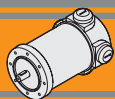

ND180.120 - ND180.240

Caratteristiche

Features

Costruzione	Tubolare, senza ventilazione
Grandezza	Ø 65 mm
Potenza	250 W S2 (180 W S1)
Magneti	4 magneti in terre rare
Supporti	Cuscinetti a sfera
Fori di montaggio	8
Alimentazione	Bassa tensione, 12 o 24 Vcc
Spazzole	N° 4 di composto grafite-rame
Cavo di alimentazione	Lunghezza: 1000 mm
Bisporgenza	Standard

Construction	Tubular, without fan
Size	Ø 65 mm
Power	250 W S2 (180 W S1)
Magnets	4 rare earth magnets
Bearings	Ball bearings
Mounting holes	8
Power supply	Low voltage, 12 or 24 Vdc
Brushes	4 brushes made of graphite/copper composite
Electric cable	Length: 1000 mm
Rear Shaft	Standard

Tipo Type	S	Pn [W]	V [V]	I [A]	IC	FF	Mn [Nm]	n ₁ [min ⁻¹]	IP	Kg
ND180.120	S1	180	12	20	F	1	0.57	3000	20	1.95
	S2 20'	250		30			0.80			
ND180.240	S1	180	24	10						
	S2 20'	250		14			0.57			
							0.80			

Dimensioni

Dimensions

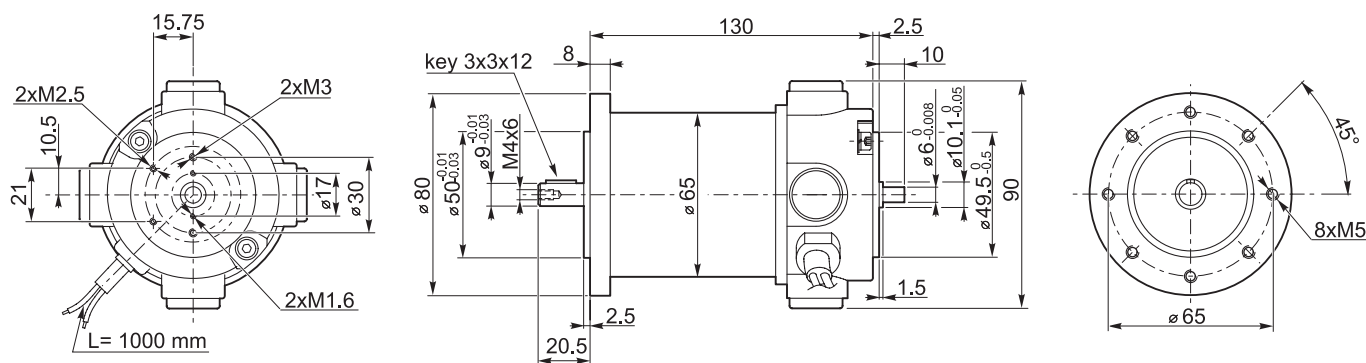

Freno / Brake → **B9**

Encoder → **B9**

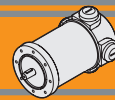

ND180.120 - ND180.240

Prestazioni

Performances

ND180.120

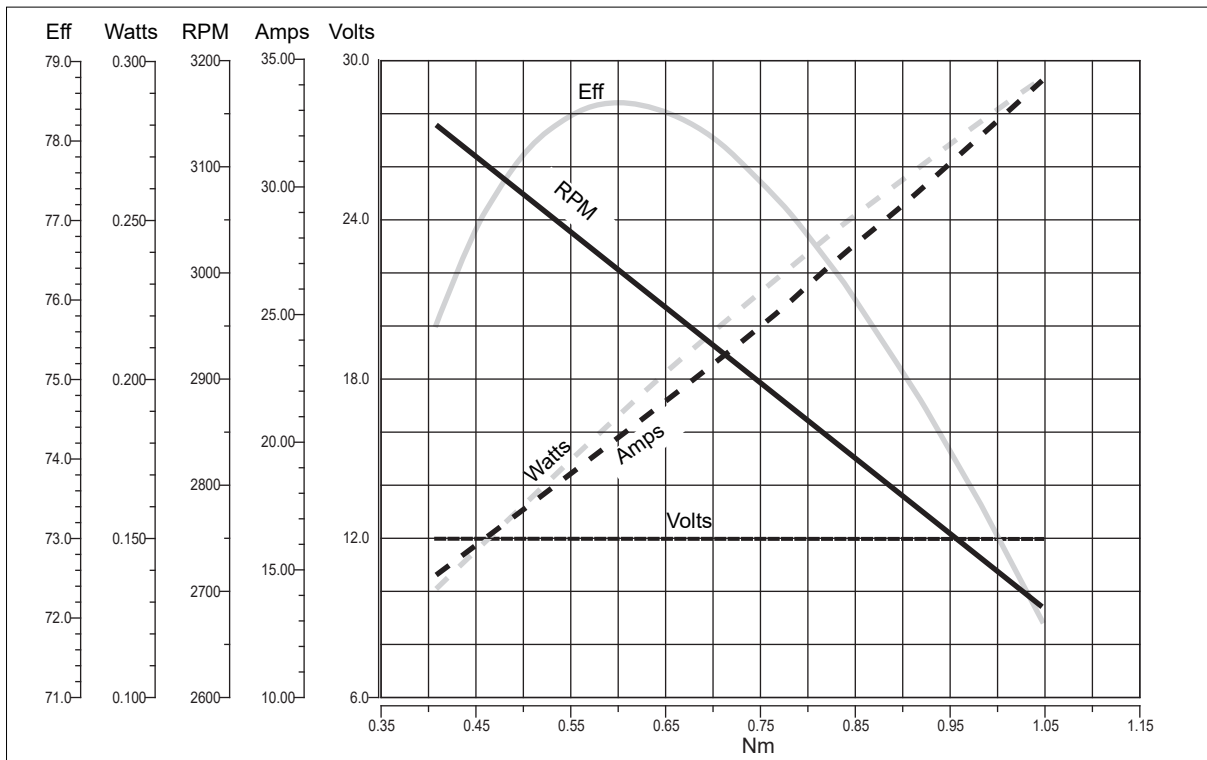

ND180.240

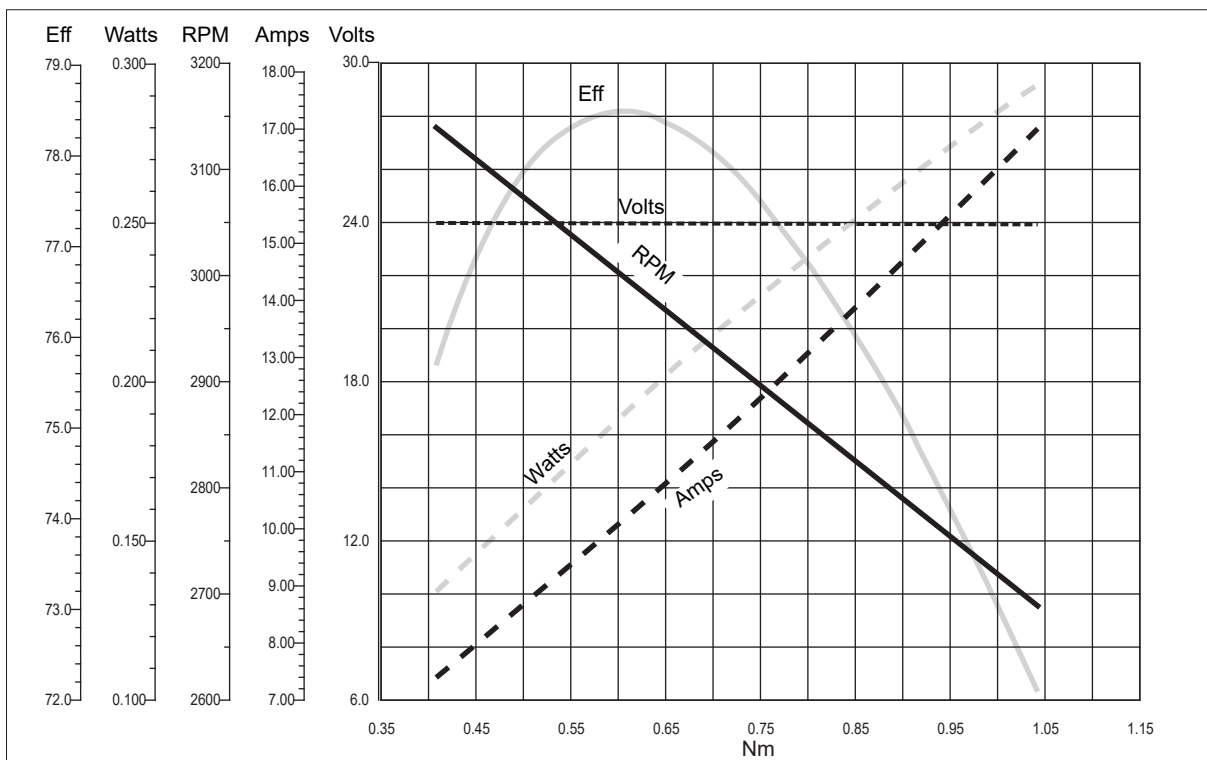

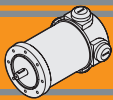

Legenda / Glossario dei grafici

Key / Diagram Glossary

Dato un motore in CC, la velocità di rotazione è funzione lineare della coppia; così pure la corrente assorbita è una funzione lineare della coppia. Velocità e corrente variano in maniera sensibile al variare del carico.

With a DC motor, the rotational speed is a linear function of the torque. In the same way, the absorbed current is also a linear function of the torque. Speed and current change a lot against applied torque.

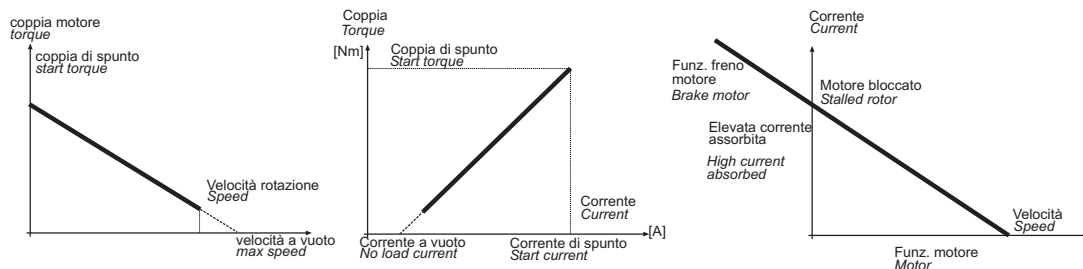

La potenza utile (potenza all'albero) si ricava dalla formula:

$$P_n [W] = M_n \cdot S = \frac{2\pi}{60} \cdot n_1 \cdot M_n$$

The output power is calculated using the formula:

$$P_n [W] = M_n \cdot S = \frac{2\pi}{60} \cdot n_1 \cdot M_n$$

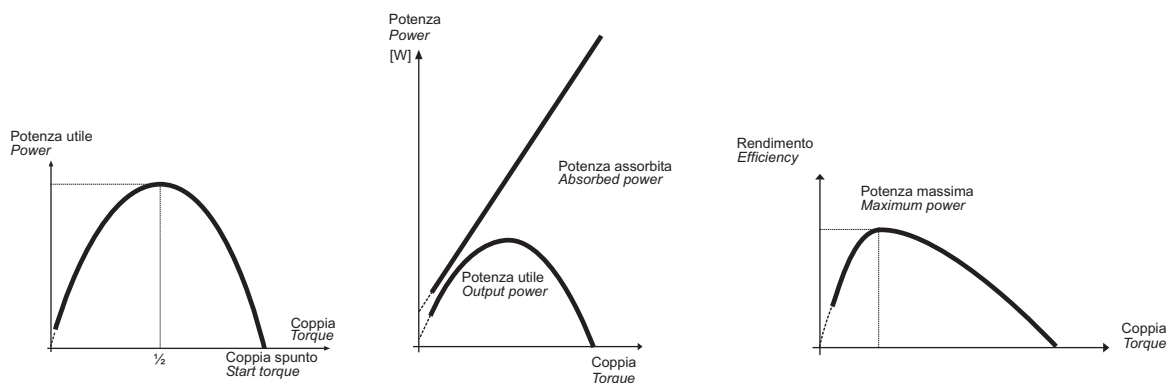

Poiché la tensione di alimentazione è costante mentre la corrente è linearmente crescente al crescere della coppia, l'andamento della potenza assorbita è una retta crescente. Dal rapporto tra la potenza meccanica e la potenza assorbita si ottiene il grafico dell'efficienza.

Since the supply voltage is constant, whereas the current increases in a linear manner as the torque increases, the absorbed power trend is a straight line going up. Efficiency is shown from the ratio between the output power and the absorbed power.

Formule utili

Useful formulas

$$\eta = \frac{P_n}{P_a}$$

$$P_a = V \cdot I$$

$$P_n = V \cdot I \cdot \eta$$

$$P_n = M_n \cdot S_v$$

$$S_v = \frac{n_1}{9.55}$$

$$\eta = \frac{P_n}{P_a}$$

$$P_a = V \cdot I$$

$$P_n = V \cdot I \cdot \eta$$

$$P_n = M_n \cdot S_v$$

$$S_v = \frac{n_1}{9.55}$$

$$[HP] \cdot 746 = [W]$$

Esempio 2 HP = circa 1500 W.

$$[HP] \cdot 746 = [W]$$

Example 2 HP = approx. 1500 W.

S	—	Servizio	Duty
P_n	[W]	Potenza in uscita	Rated power
P_a	[W]	Potenza assorbita	Absorbed power
M_n	[Nm]	Coppia nominale	Rated torque
V	[V]	Tensione	Voltage
I	[A]	Corrente assorbita	Absorbed current
n₁	[min ⁻¹]	Numero giri motore	Motor speed
S_v	[rad/s]	Velocità angolare	Angular speed
IC	—	Classe d'isolamento termico	Thermal insulation class
FF	—	Fattore di forma	Form factor
IP	—	Classe di protezione	Protection class
η	—	Rendimento	Efficiency
Kg	—	Peso	Weight

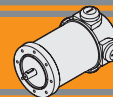

Freno

Brake

ND...BR Freno / Brake

ND...BRL Freno con leva di sblocco/ Brake with hand release

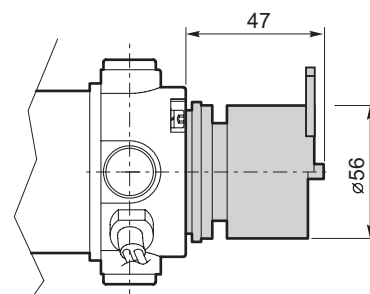
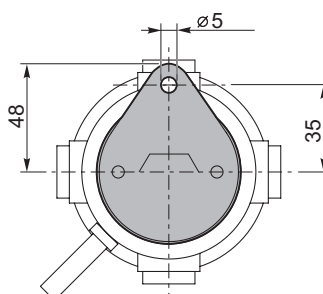
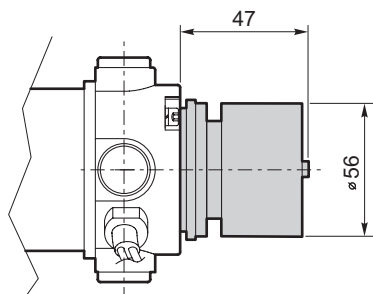

	Pn [W]	V [V]	Mn [Nm]	n ₁ [min ⁻¹]
Caratteristiche del freno / Break features	14	12 24	2	3000

Encoder

Encoder

ND...ME22

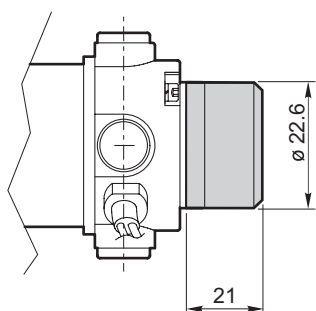

Nota: Fornito con cavo lungo 300 mm

Note: Supplie with cavle 300 mm long

Risoluzione Encoder (CPR) / Encoder Resolution (CPR)	Numero di canali / Number of channels	Tensione d'alimentazione / Power supply
001	2	5 VdC - TTL
100		
300		

Per risoluzioni encoder non standard, si prega di contattare il nostro Servizio Tecnico.

For non-standard encoder resolution, please contact our Technical Department.



Neodymium

Motoriduttori CC ad ingranaggi cilindrici DC helical in-line gearmotors



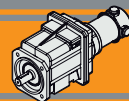

Indice	Index	Pag. Page
Caratteristiche tecniche	<i>Technical features</i>	C2
Designazione	<i>Classification</i>	C3
Sensi di rotazione	<i>Direction of rotation</i>	C3
Lubrificazione	<i>Lubrication</i>	C3
Simbologia	<i>Symbols</i>	C4
Carichi radiali	<i>Radial loads</i>	C4
Dati tecnici per servizio S2	<i>Technical data for S2 duty</i>	C5
Motori applicabili	<i>IEC Motor adapters</i>	C6
Dimensioni	<i>Dimensions</i>	C7

Questa sezione annulla e sostituisce ogni precedente edizione o revisione. Qualora questa sezione non Vi sia giunta in distribuzione controllata, l'aggiornamento dei dati ivi contenuto non è assicurato. **In tal caso la versione più aggiornata è disponibile sul nostro sito internet www.transtecno.com**

This section replaces any previous edition and revision. If you obtained this catalogue other than through controlled distribution channels, the most up to date content is not guaranteed. In this case the latest version is available on our web site www.transtecno.com

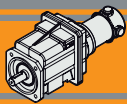

Caratteristiche tecniche

Le caratteristiche principali dei motoriduttori CC ad ingranaggi cilindrici a magneti permanenti in neodimio NDCMG sono:

- Alimentazione in bassa tensione 12/24 Vcc
- Possibilità di montaggio encoder
- Potenze motore disponibili da 160 a 250W S2
- Magneti in Neodimio
- Carcasse dei riduttori in pressofusione di alluminio
- Lubrificazione permanente con olio sintetico
- Ingranaggi sempre rettificati

Technical features

The main features of NDCMG neodymium permanent magnets DC helical in-line gearmotors range are:

- Low voltage power supply 12/24 Vdc
- Suitable for encoder assembly
- Motor power ratings available from 160 to 250W S2
- Neodymium magnets
- Die-cast aluminum housing
- Permanent synthetic oil long-life lubrication
- Ground helical gears

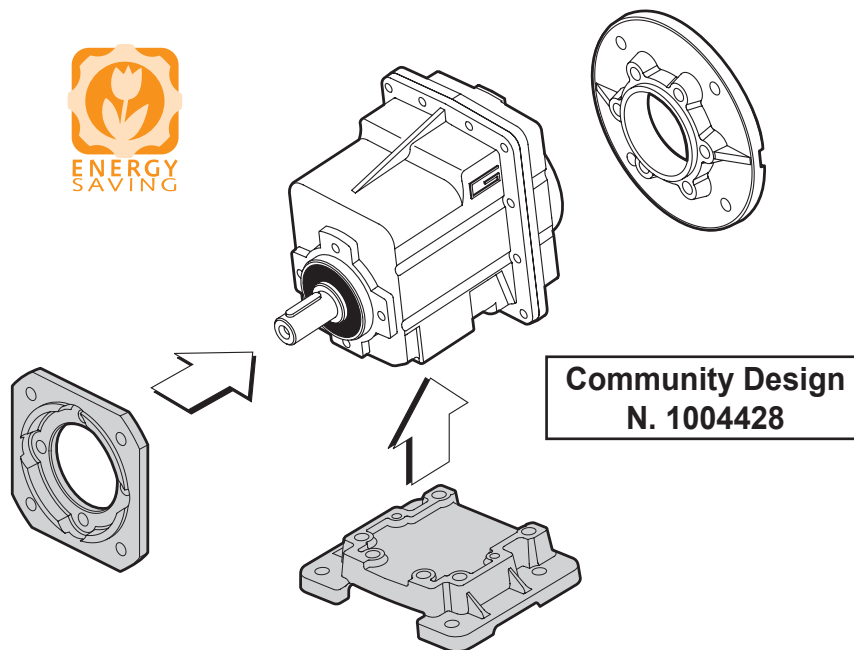

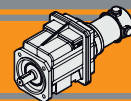

Designazione

Classification

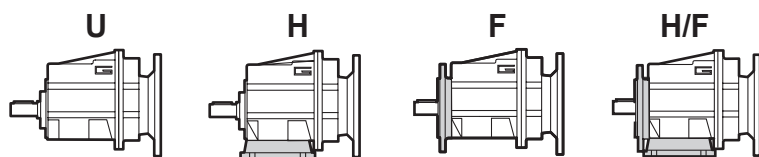

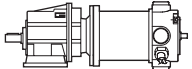
MOTORIDUTTORE / GEARMOTOR						
NDCMG	120/002		U	8.99	D20	240
Tipo Type	Grandezza Size		Versione Version	Rapporto Ratio	Albero uscita Output shaft	Versione motore Motor version
NDCMG 	120/002 120/012 120/013 120/022 120/023 120/033 120/043	180/002 180/012 180/013 180/022 180/023 180/033 180/043	U... H... F... H.../F...	vedi tabelle see tables	vedi tabelle see tables	120 240

Sensi di rotazione

Direction of rotation

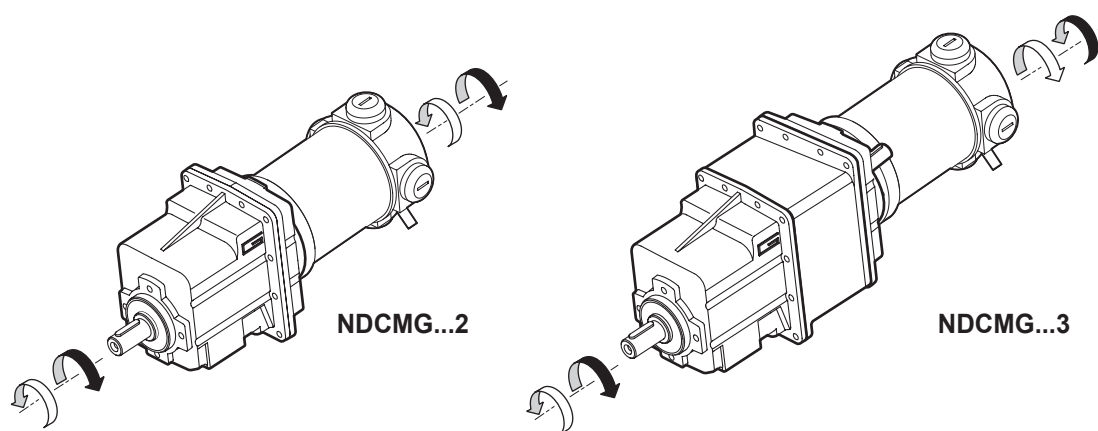

Lubrificazione

Lubrication

Tutti i riduttori nelle taglie 002 sono forniti completi di lubrificante sintetico viscosità 320, pertanto possono essere installati in qualunque posizione di montaggio e non necessitano di manutenzione.

Permanent synthetic oil long-life lubrication (viscosity grade 320) makes it possible to use sizes 002 in all mounting positions; for this reason they can be installed in any assembly position and do not require maintenance.

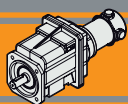

Simbologia

Symbols

n_1	[min ⁻¹]	Velocità in ingresso / <i>Input speed</i>
n_2	[min ⁻¹]	Velocità in uscita / <i>Output speed</i>
i		Rapporto di riduzione / <i>Ratio</i>
P_1	[kW]	Potenza in entrata / <i>Input power</i>
M_2	[Nm]	Coppia nominale in uscita in funzione di P_1 / <i>Output torque referred to P_1</i>
sf		Fattore di servizio / <i>Service factor</i>
R_2	[N]	Carico radiale ammissibile in uscita / <i>Permitted output radial load</i>
A_2	[N]	Carico assiale ammissibile in uscita / <i>Permitted output axial load</i>

Carichi radiali

Radial loads

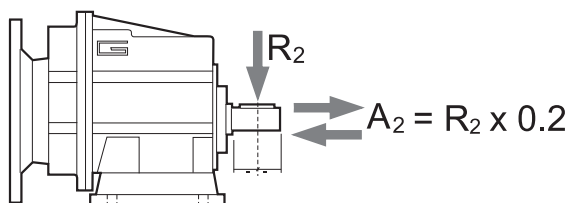

n_2 [min ⁻¹]	R_2 [N]				
	CMG 00	CMG 01	CMG 02	CMG 03	CMG 04
700	416	764	1529	1987	2379
600	437	805	1609	2092	2504
500	465	855	1710	2223	2661
400	501	921	1842	2395	2866
250	586	1077	2154	2801	3353
180	653	1323	2554	3321	3897
150	748	1406	2714	3529	4244
120	806	1631	3467	3801	4572
100	958	1842	3684	4507	5234
80	1032	1984	3969	5042	5991
60	1136	2184	4368	5549	6594
40	1300	2500	5000	6500	8000
10	1300	2500	5000	6500	8000

Quando il carico radiale risultante non è applicato sulla mezzeria dell'albero occorre calcolare quello effettivo con la seguente formula:

When the resulting radial load is not applied on the centre line of the shaft it is necessary to calculate the effective load with the following formula:

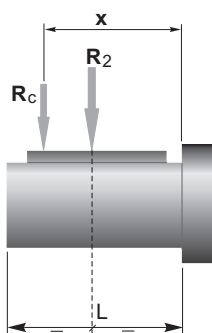

	CMG 00	CMG 01	CMG 02	CMG 03	CMG 04
a	73	104	117	132	150
b	53	84	92	102	115
R_{2MAX}	1300	2500	5000	6500	8000

$$R_c = \frac{R_2 \cdot a}{(b + x)} \leq R_{2MAX}$$

a, b = valori riportati nella tabella
 a, b = values given in the table

$$R \leq R_c$$

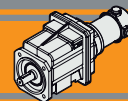

Dati tecnici per servizio S2

Technical data for S2 duty

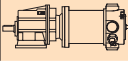
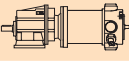
P_1 [W]	n_2 [min ⁻¹]	M_2 [Nm]	sf	i		Versione motore Motor version	P_1 [W]	n_2 [min ⁻¹]	M_2 [Nm]	sf	i		Versione motore Motor version				
160							250										
(3000 min ⁻¹)	596	2.5	12.6	5.03	120/002	120/240	(3000 min ⁻¹)	596	3.8	8.1	5.03	180/002	120/240				
	492	3.0	10.4	6.10						492	4.7			6.7	6.10		
	401	3.7	8.5	7.49						401	5.7			5.4	7.49		
	334	4.4	8.9	8.99						334	6.9			5.7	8.99		
	295	5.0	7.9	10.16						295	7.8			5.0	10.16		
	249	5.9	6.6	12.07						249	9.2			4.2	12.07		
	224	6.6	8.4	13.40						224	10			5.4	13.40		
	198	7.4	7.4	15.14						198	12			4.8	15.14		
	165	8.9	6.2	18.17						165	14			4.0	18.17		
	139	11	5.2	21.58						139	17			3.3	21.58		
	128	12	4.8	23.51						128	18			3.1	23.51		
	120	12	4.5	25.10						120	19			2.9	25.10		
	111	13	4.2	27.08						111	21			2.7	27.08		
	92	16	3.5	32.49						92	25			2.2	32.49		
	71	21	2.7	42.04						71	32			1.7	42.04		
	67	22	2.5	44.89						67	34			1.6	44.89		
	61	24	2.3	48.86						61	37			1.5	48.86		
	54	27	2.0	55.10													
	85	17	5.4	35.47			120/012	120/240		127	18			5.2	23.56	180/012	120/240
	65	22	4.2	45.89					101	23	4.2	29.56					
	61	24	3.9	49.00					85	27	3.5	35.47					
	56	26	3.6	53.33					65	35	2.7	45.89					
	50	29	3.2	60.15					61	37	2.5	49.00					
	47	30	3.1	63.22	120/013	120/240		56	41	2.3	53.33						
	40	36	2.6	75.08					50	46	2.0	60.15					
	34	43	2.2	89.17					47	47	2.0	63.22	180/013	120/240			
	27	54	1.7	113.05					40	56	1.7	75.08					
	22	64	1.5	134.27					34	67	1.4	89.17					
	17	83	1.1	173.72					27	85	1.1	113.05					
	15	97	1.0	202.16					22	100	0.9	134.27					
	11	125	0.8	261.57					17	130	0.7	173.72					
	10	134	0.7	304.00					15	134	0.7	202.16					
	7.6	134	0.7	393.33					11	134	0.7	261.57					
	6.8	134	0.7	443.59			10	134	0.7	304.00							
							7.6	134	0.7	393.33							
							6.8	134	0.7	443.59							
	33	43	3.6	90.29	120/023	120/240		65	35	4.4	46.46	180/022	120/240				
	26	55	2.8	114.46					60	38	4.1			49.61			
	22	65	2.4	135.95					56	41	3.8			54.00			
	17	84	1.9	175.89					49	47	3.4			60.90			
	15	98	1.6	204.69													
	11	127	1.2	264.84													
	10	147	1.1	307.80													
	7.5	191	0.8	398.25													
	6.7	215	0.7	449.14													
	17	83	2.8	174.26			120/033	120/240									
	13	108	2.2	225.47													
	11	125	1.9	262.05													
	9.2	156	1.5	325.79													
	7.9	181	1.3	378.64													
	7.0	204	1.1	427.03													
	11	125	3.1	262.05	120/043	120/240											
	9.2	156	2.5	325.79													
	7.9	181	2.2	378.64													
	7.0	204	1.9	427.03													

NDCMG

N.B.
Verificare sempre che la coppia M2 utilizzata non ecceda il valore indicato nelle caselle in grigio
N.B.
Please check that the output torque M2 does not exceed the value in the grey areas

NOTA: per servizio continuo o altamente intermittente, contattare il servizio tecnico
NOTE: for continuous or highly intermittent duty, please contact our technical service

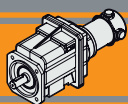

Dati tecnici per servizio S2

Technical data for S2 duty

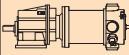
P ₁ [W]	n ₂ [min ⁻¹]	M ₂ [Nm]	sf	i		Versione motore Motor version
250						
(3000 min ⁻¹)	47	48	3.3	64.01	180/023	120/240
	39	57	2.7	76.02		
	33	68	2.3	90.29		
	26	86	1.8	114.46		
	22	102	1.5	135.95		
	17	132	1.2	175.89		
	15	153	1.0	204.69		
	11	198	0.8	264.84		
	10	223	0.7	307.80		
	7.5	223	0.7	398.25		
	6.7	223	0.7	449.14		

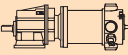
P ₁ [W]	n ₂ [min ⁻¹]	M ₂ [Nm]	sf	i		Versione motore Motor version
250						
(3000 min ⁻¹)	41	54	4.3	72.83	180/033	120/240
	31	73	3.2	97.45		
	26	87	2.7	115.74		
	21	105	2.2	140.81		
	17	130	1.8	174.26		
	13	169	1.4	225.47		
	11	196	1.2	262.05		
	9.2	244	1.0	325.79		
	7.9	283	0.8	378.64		
	7.0	319	0.7	427.03		
	21	105	3.7	140.81	180/043	120/240
	17	130	3.0	174.26		
	13	169	2.3	225.47		
	11	196	2.0	262.05		
	9.2	244	1.6	325.79		
	7.9	283	1.4	378.64		
	7.0	319	1.2	427.03		

N.B.
Verificare sempre che la coppia M₂ utilizzata non ecceda il valore indicato nelle caselle in grigio
N.B.
Please check that the output torque M₂ does not exceed the value in the grey areas

NOTA: per servizio continuo o altamente intermittente, contattare il servizio tecnico

NOTE: for continuous or highly intermittent duty, please contact our technical service

Motori applicabili

IEC Motor adapters

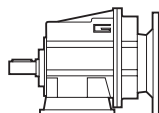
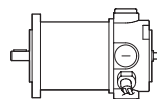

		ND	
		120.120 120.240	180.120 180.240
CMG	002	5.03 - 55.10	
	012	3.82 - 60.15	
	013	63.22 - 443.59	
	022	3.66 - 60.9	
	023	64.01 - 449.14	
	033	72.83 - 427.03	
	043	72.83 - 427.03	

5.03 - 55.10

Rapporti di riduzione i
Ratio i

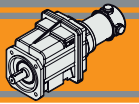

Dimensioni

Dimensions

NDCMG..U

NDCMG120/002 U
NDCMG180/002 U

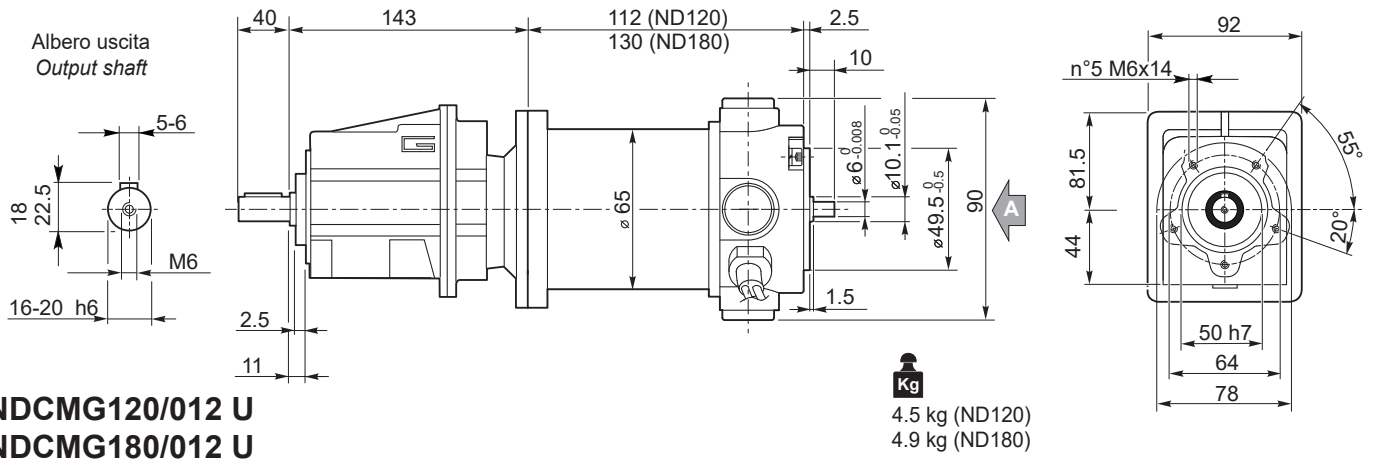

NDCMG120/012 U
NDCMG180/012 U

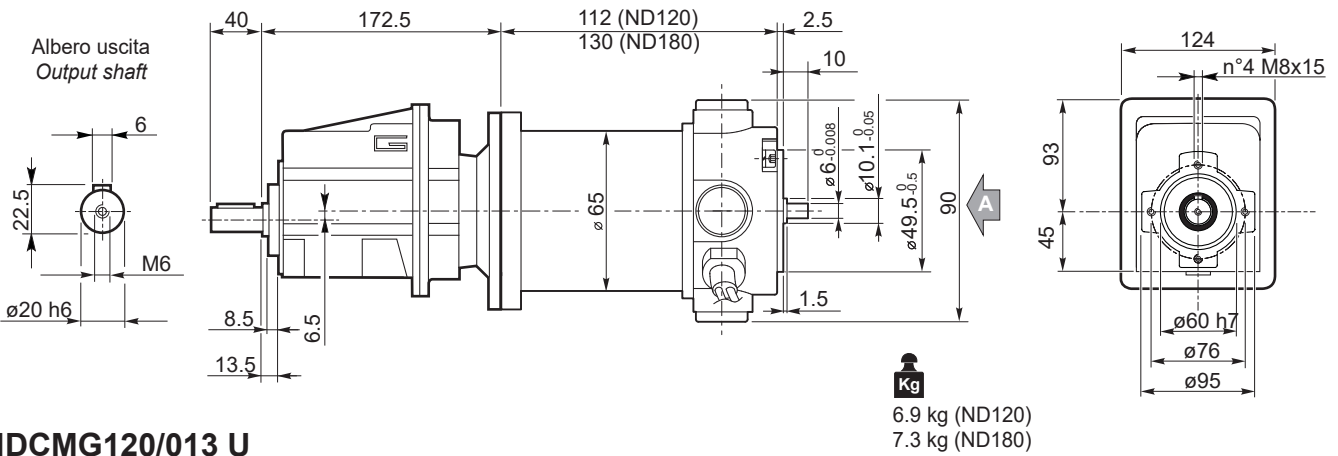

NDCMG120/013 U
NDCMG180/013 U

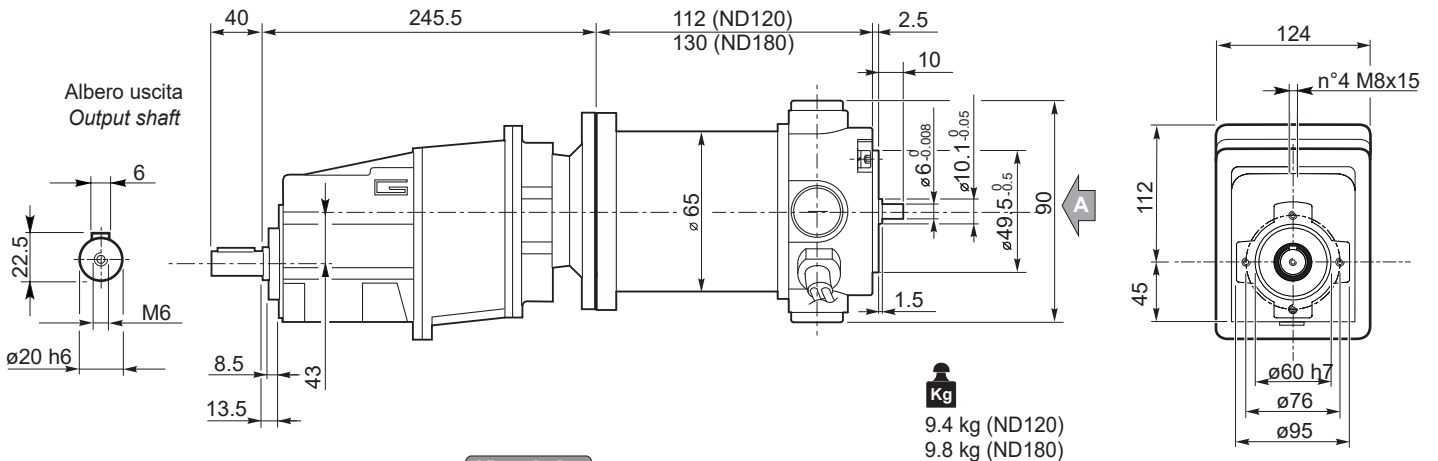

Vista da A
View from A

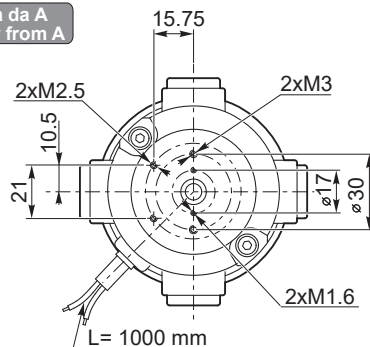

NDCMG...H → C10

NDCMG...F → C11

NDCMG...H/F → C12

Freno / Brake → B9

Encoder → B9

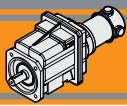

Dimensioni

Dimensions

NDCMG..U

NDCMG120/022 U NDCMG180/022 U

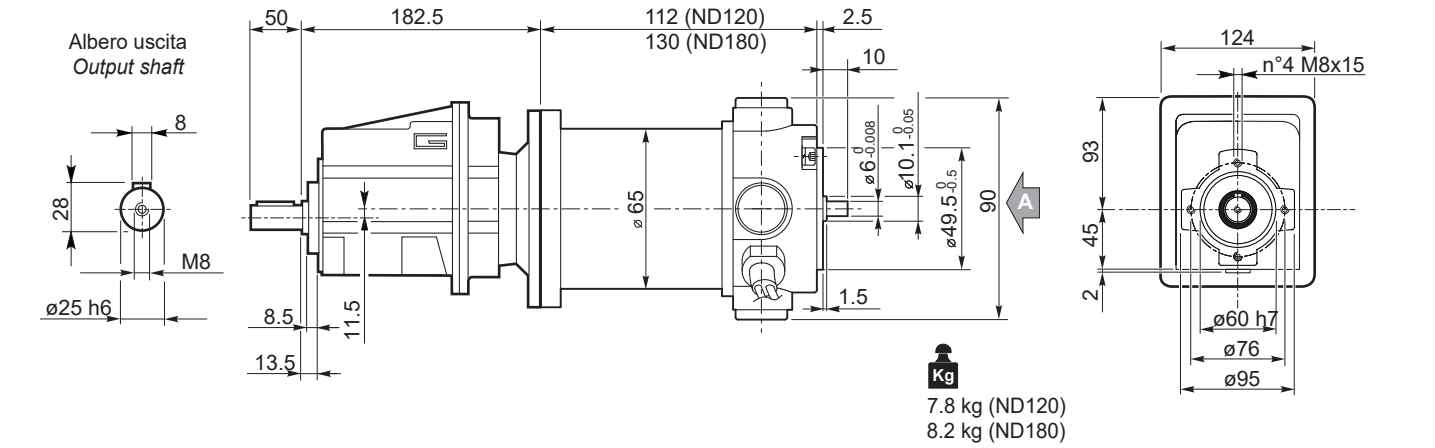

NDCMG120/023U NDCMG180/023 U

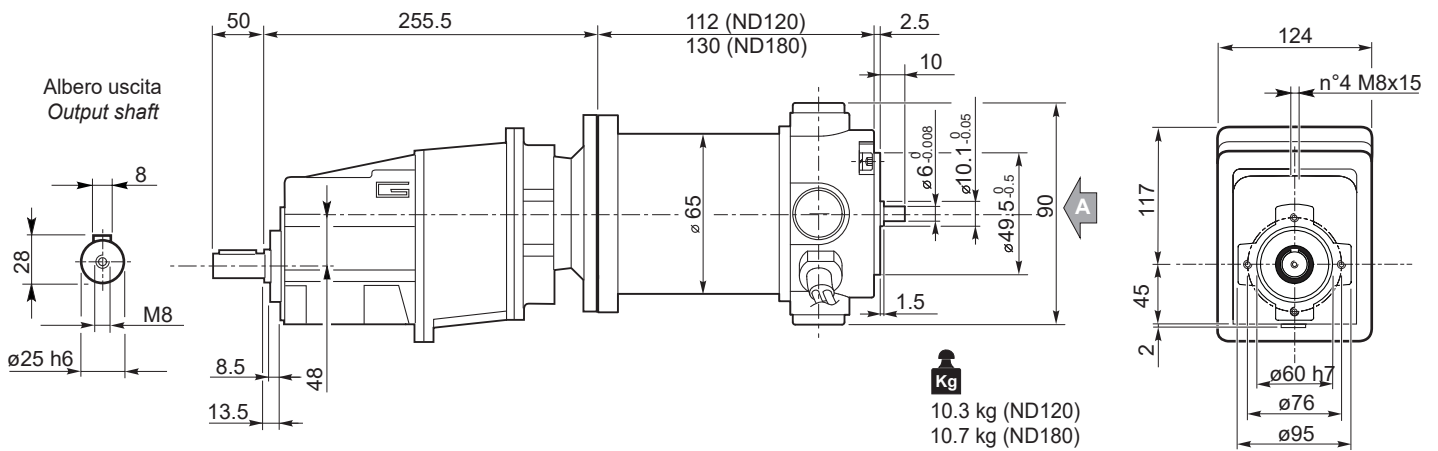

Vista da A
View from A

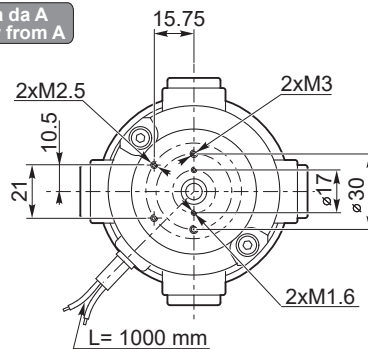

NDCMG...H



NDCMG...F



NDCMG...H/F



Freno / Brake



Encoder



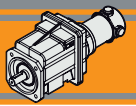

Dimensioni

Dimensions

NDCMG..U

NDCMG120/033 U
NDCMG180/033 U

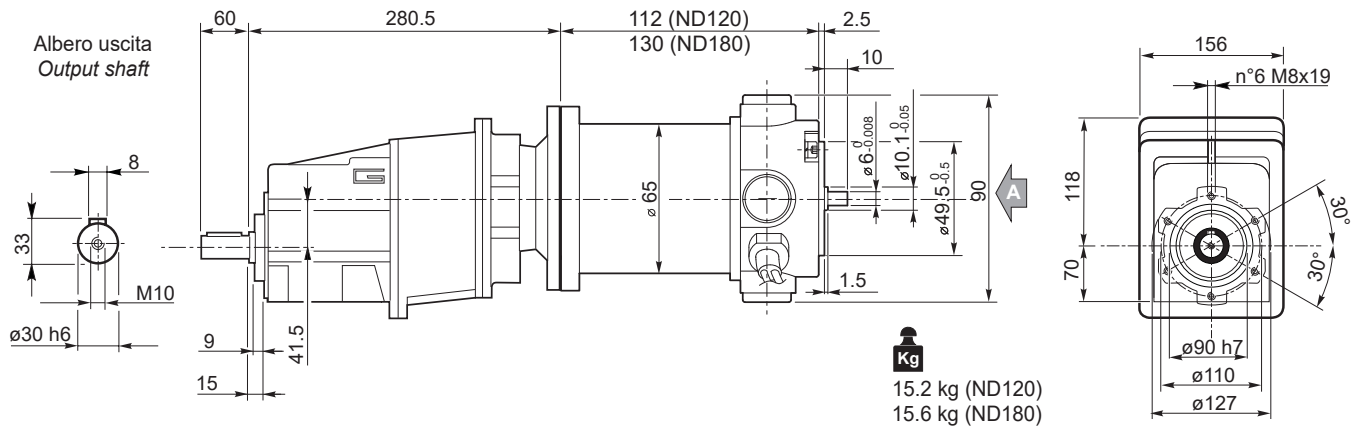

NDCMG120/043 U
NDCMG180/043 U

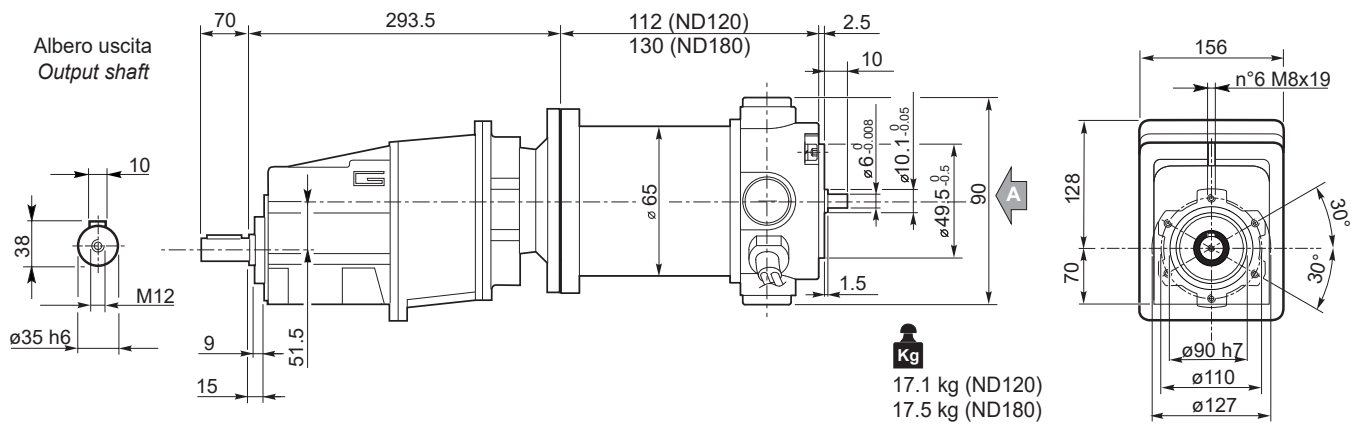

NDCMG...H



NDCMG...F



NDCMG...H/F



Vista da A
View from A

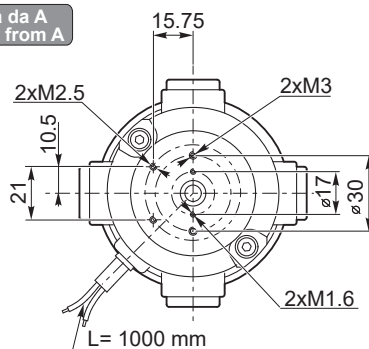

Freno / Brake

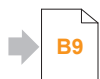

Encoder



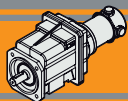

Dimensioni

Dimensions

NDCMG..H

NDCMG..2 H..

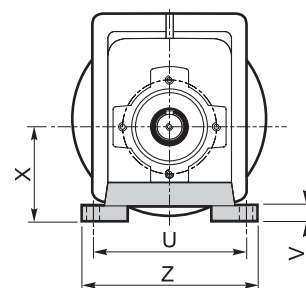
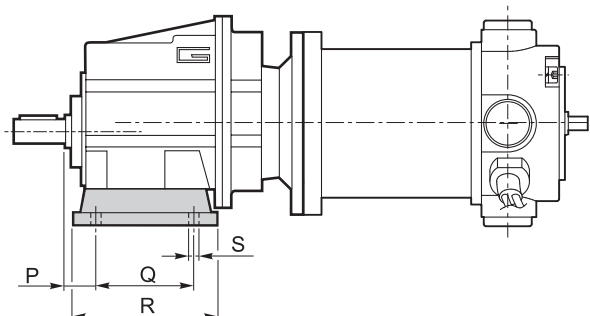

NDCMG..3 H..

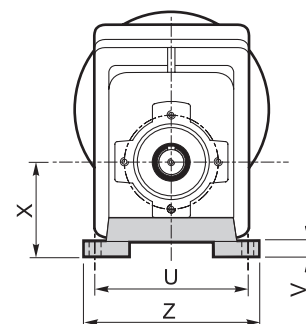
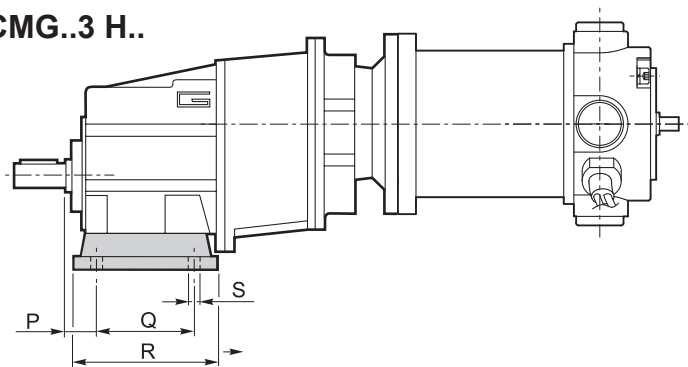

Versione H / H Version

CMG	P	Q	R	S	U	V	X	Z	Piede / Foot	
									Tipo / Type	Peso / Weight [kg]
002	18	60	80	9	100	10	60	120	H60	0.2
	18	80	104	9	110 - 120	10	75	145	H75	0.3
	18	50 - 87	110	9	110	10	85	135	H85	0.4
012 013	20	85	108	9	115	12	65	139	H65	0.7
	18	80	118	9	110	12	75	140	H75	1.0
	25	85	120	9	120	12	80	140	H80	1.1
	18	50 - 87	118	9	110	12	85	130	H85	1.2
	25	130	154	9	110	12	90	135	H90	1.5
022 023	18	60 - 107.5	135	11	130	12	100	155	H100	1.7
	20	85	108	9	115	12	65	139	H65	0.7
	18	80	118	9	110	12	75	140	H75	1.0
	25	85	120	9	120	12	80	140	H80	1.1
	18	50 - 87	118	9	110	12	85	130	H85	1.2
033	25	130	154	9	110	12	90	135	H90	1.5
	18	60 - 107.5	135	11	130	12	100	155	H100	1.7
	30	105	136	14	160	14	95	194	H95	1.5
	30	100	150	11	150	14	110	185	H110	1.9
	18	70			160					
30	165	195	14	135	14	115	170	H115	2.2	
35	110	160	14	170	14	120	210	H120	2.6	
043	30	105	136	14	160	14	95	194	H95	1.5
	30	100	150	11	150	14	110	185	H110	1.9
	18	70			160					
	30	165	195	14	135	14	115	170	H115	2.2
	35	110	160	14	170	14	120	210	H120	2.6

Preferenziale / Preferred

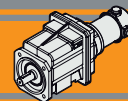

Dimensioni

Dimensions

NDCMG..F

NDCMG..2 F..

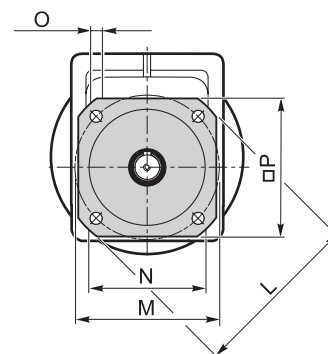
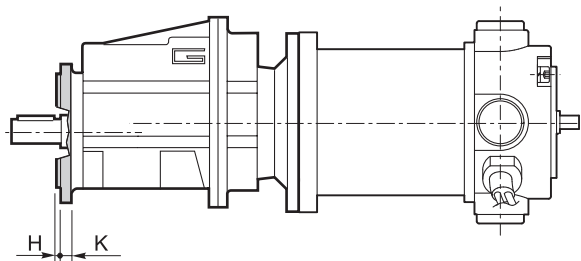

NDCMG..3 F..

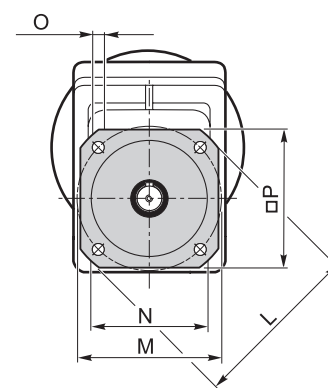
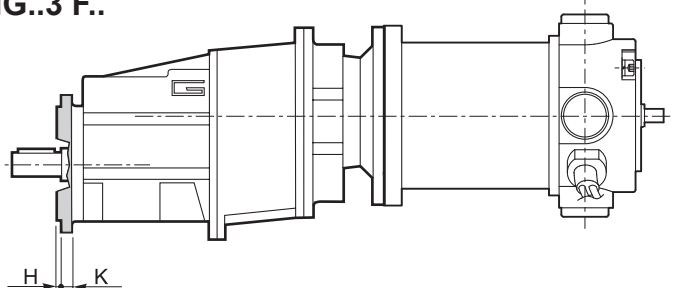

NDCMG

Versione F / F Version

CMG	H	K	L	M	N f7	O	P	Flangia / Flange	
								Tipo / Type	Peso / Weight [kg]
002	3.5	7	105	85	70	6.5	90	F105	0.1
	3.5	8	120	100	80	7	100	F120	0.2
	3.5	8	140	115	95	9	115	F140	0.2
012 013	3	9	120	100	80	9	106	F120	0.5
	3.5	9	140	115	95	9	115	F140	0.8
	3.5	9	160	130	110	9	126	F160	1.1
	3.5	11	200	165	130	11	165	F200	1.8
022 023	3	9	120	100	80	9	106	F120	0.5
	3.5	9	140	115	95	9	115	F140	0.8
	3.5	9	160	130	110	9	126	F160	1.1
	3.5	11	200	165	130	11	165	F200	1.8
033	3.5	11	160	130	110	9	140	F160	1.0
	3.5	11	200	165	130	11	165	F200	1.8
	4	13	250	215	180	14	215	F250	2.9
043	3.5	11	160	130	110	9	140	F160	1.0
	3.5	11	200	165	130	11	165	F200	1.8
	4	13	250	215	180	14	215	F250	2.9

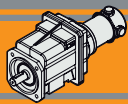

Dimensioni

Dimensions

Versione H / H Version											Combinazioni possibili H/F Possible combinations H/F						
CMG	P	Q	R	S	U	V	X	Z	Piede / Foot		F105	F120	F140	F160	F200	F250	F300
									Tipo / Type	Peso / Weight [kg]							
002	18	60	80	9	100	10	60	120	H60	0.2	•	•	•				
	18	80	104	9	110 - 120	10	75	145	H75	0.3	•	•	•				
	18	50 - 87	110	9	110	10	85	135	H85	0.4	•	•	•				
012 013	20	85	108	9	115	12	65	139	H65	0.7		•	•				
	18	80	118	9	110	12	75	140	H75	1.0		•	•	•			
	25	85	120	9	120	12	80	140	H80	1.1		•	•	•			
	18	50 - 87	118	9	110	12	85	130	H85	1.2		•	•	•			
	25	130	154	9	110	12	90	135	H90	1.5		•	•	•	•		
	18	60 - 107.5	135	11	130	12	100	155	H100	1.7		•	•	•	•		
022 023	20	85	108	9	115	12	65	139	H65	0.7		•	•				
	18	80	118	9	110	12	75	140	H75	1.0		•	•	•			
	25	85	120	9	120	12	80	140	H80	1.1		•	•	•			
	18	50 - 87	118	9	110	12	85	130	H85	1.2		•	•	•			
	25	130	154	9	110	12	90	135	H90	1.5		•	•	•	•		
	18	60 - 107.5	135	11	130	12	100	155	H100	1.7		•	•	•	•		
033	30	105	136	14	160	14	95	194	H95	1.5				•	•		
	30	100	150	11	150	14	110	185	H110	1.9				•	•		
	18	70			160												
	30	165	195	14	135	14	115	170	H115	2.2				•	•	•	
	35	110	160	14	170	14	120	210	H120	2.6				•	•	•	
043	30	105	136	14	160	14	95	194	H95	1.5				•	•		
	30	100	150	11	150	14	110	185	H110	1.9				•	•		
	18	70			160												
	30	165	195	14	135	14	115	170	H115	2.2				•	•	•	
	35	110	160	14	170	14	120	210	H120	2.6				•	•	•	

■ Preferenziale / Preferred

• Combinazioni possibili H/F / Possible combinations H/F

Versione F / F Version									
CMG	H	K	L	M	N f7	O	P	Flangia / Flange	
								Tipo / Type	Peso / Weight [kg]
002	3.5	7	105	85	70	6.5	90	F105	0.1
	3.5	8	120	100	80	7	100	F120	0.2
	3.5	8	140	115	95	9	115	F140	0.2
012 013	3	9	120	100	80	9	106	F120	0.5
	3.5	9	140	115	95	9	115	F140	0.8
	3.5	9	160	130	110	9	126	F160	1.1
	3.5	11	200	165	130	11	165	F200	1.8
022 023	3	9	120	100	80	9	106	F120	0.5
	3.5	9	140	115	95	9	115	F140	0.8
	3.5	9	160	130	110	9	126	F160	1.1
	3.5	11	200	165	130	11	165	F200	1.8
033	3.5	11	160	130	110	9	140	F160	1.0
	3.5	11	200	165	130	11	165	F200	1.8
	4	13	250	215	150	14	215	F250	2.9
043	3.5	11	160	130	110	9	140	F160	1.0
	3.5	11	200	165	130	11	165	F200	1.8
	4	13	250	215	150	14	215	F250	2.9

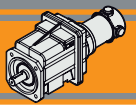

Dimensioni

Dimensions

NDCMG..H../F..

NDCMG..2 H../F..

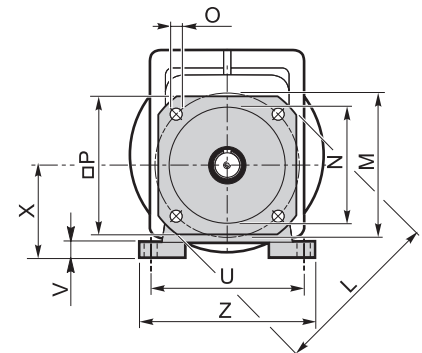
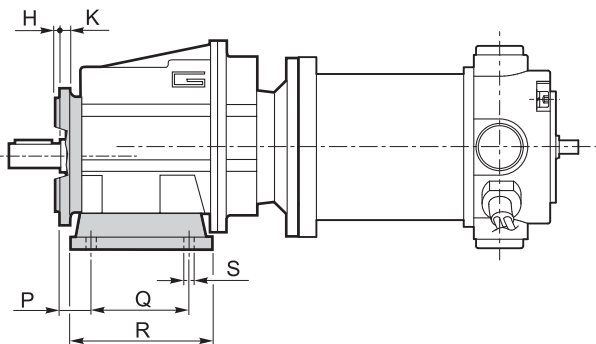

NDCMG..3 H../F..

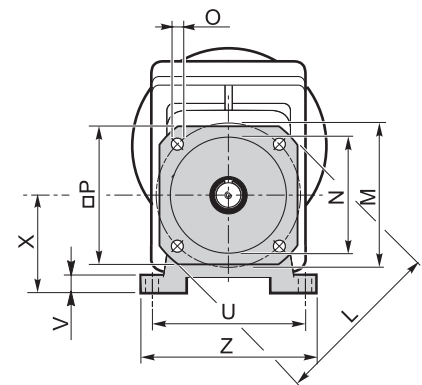
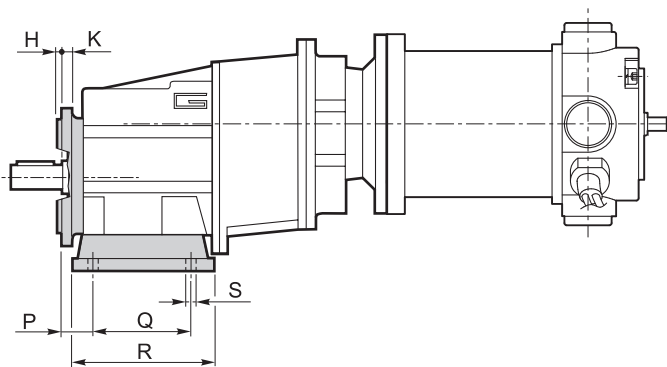

NDCMG



Neodymium

Motoriduttori CC ad assi ortogonali DC helical bevel gearmotors

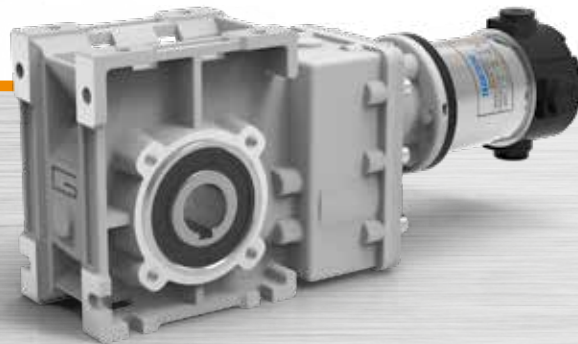

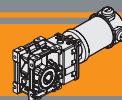

Indice	Index	Pag. Page
Caratteristiche tecniche	<i>Technical features</i>	D2
Designazione	<i>Classification</i>	D2
Sensi di rotazione	<i>Direction of rotation</i>	D2
Simbologia	<i>Symbols</i>	D2
Lubrificazione	<i>Lubrication</i>	D3
Carichi radiali	<i>Radial loads</i>	D3
Dati tecnici	<i>Technical data</i>	D4
Motori applicabili	<i>Motor adapters</i>	D4
Dimensioni	<i>Dimensions</i>	D5
Accessori	<i>Accessories</i>	D8

Questa sezione annulla e sostituisce ogni precedente edizione o revisione. Qualora questa sezione non Vi sia giunta in distribuzione controllata, l'aggiornamento dei dati ivi contenuto non è assicurato. **In tal caso la versione più aggiornata è disponibile sul nostro sito internet www.transtecno.com**

*This section replaces any previous edition and revision. If you obtained this catalogue other than through controlled distribution channels, the most up to date content is not guaranteed. **In this case the latest version is available on our web site www.transtecno.com***

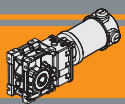

Caratteristiche tecniche

Technical features

Le caratteristiche principali dei motoriduttori CC ad assi ortogonali a magneti permanenti in neodimio NDCMB sono:

The main features of NDCMB neodymium permanent magnets DC helical bevel gearmotors range are:

- Alimentazione in bassa tensione 12/24 Vcc
- Possibilità di montaggio encoder
- Potenze motore disponibili da 160 a 250W S2
- Magneti in Neodimio
- Carcasse dei riduttori in pressofusione di alluminio
- Lubrificazione permanente con olio sintetico
- Ingranaggi sempre rettificati

- Low voltage power supply 12/24 Vdc
- Suitable for encoder assembly
- Motor power ratings available from 160 to 250W S2
- Neodymium magnets
- Die-cast aluminum housing
- Permanent synthetic oil long-life lubrication
- Ground helical gears

Designazione

Classification

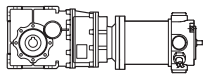
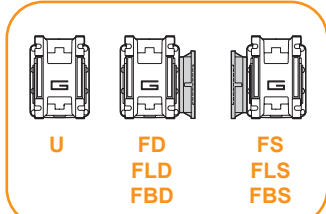
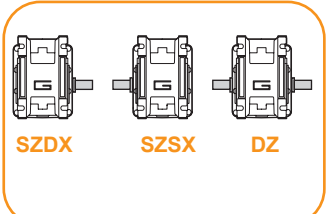
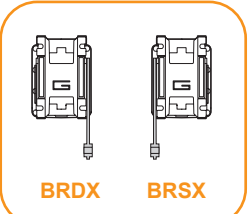
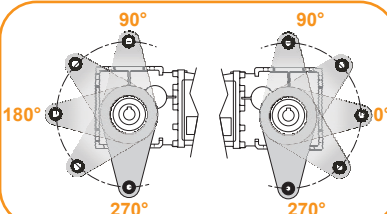
MOTORIDUTTORE / GEARMOTOR									
NDCMB	120/402		U	9.2	D20	SZDX	BR SX	90	240
Tipo Type	Grandezza Size		Versione Riduttore Gearbox Version	Rapporto Ratio	Albero di uscita Output shaft	Albero di uscita Output shaft	Braccio di reazione Torque arm	Angolo Angle	Versione Motore Motor Version
	120/402 120/502 120/633	180/402 180/502 180/633	U FD FS FLD FLS FBD FBS	Vedere tabella See tables	Vedere tabella See tables	SZDX SZSX DZ	BRDX BR SX	0° 90° 180° 270°	120 240
Versione Riduttore Gearbox Version			Albero di uscita Output shaft		Braccio di reazione (*) Torque arm		Angolo (*) Angle		
									

(*) NOTA:
Il braccio di reazione viene fornito smontato.
NOTE:
The torque arm will be supplied not assembled

Sensi di rotazione

Direction of rotation

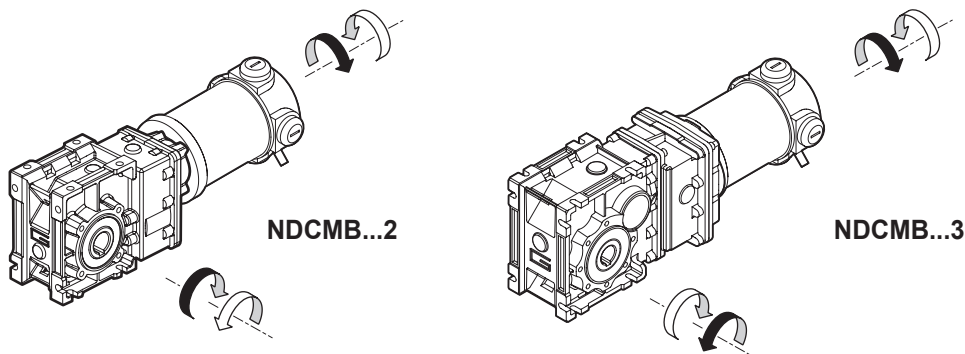

Simbologia

Symbols

n_1 [min ⁻¹]	Velocità in ingresso / Input speed	M_2 [Nm]	Coppia in uscita in funzione di P_1 / Output torque referred to P_1
n_2 [min ⁻¹]	Velocità in uscita / Output speed	sf	Fattore di servizio / Service factor
i	Rapporto di riduzione / Ratio	A_2 [N]	Carico assiale ammissibile in uscita / Permitted output axial load
P_1 [kW]	Potenza in entrata / Input power	R_2 [N]	Carico radiale ammissibile in uscita / Permitted output radial load

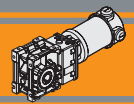

Lubrificazione

Lubrication

Tutti i riduttori nelle taglie 402 e 502 sono forniti completi di lubrificante sintetico viscosità 320, pertanto possono essere installati in qualunque posizione di montaggio e non necessitano di manutenzione.

Permanent synthetic oil long-life lubrication (viscosity grade 320) makes it possible to use sizes 402 and 502 in all mounting positions; for this reason they can be installed in any assembly position and do not require maintenance.

Carichi radiali

Radial loads

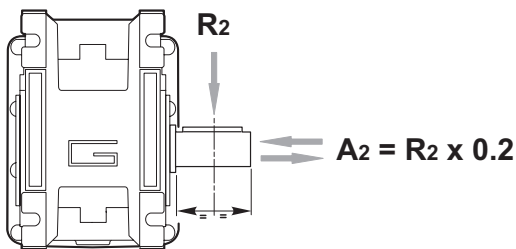

n ₂ [min ⁻¹]	R ₂ [N]		
	CMB 402	CMB 502	CMB 633
400	905	1116	1835
300	996	1228	2020
200	1141	1406	2312
170	1204	1484	2441
140	1414	1743	2604
100	1582	1949	2913
90	1638	2019	3321
60	2047	2490	3801
40	2524	3029	4492
30	2778	3334	5159
20	3180	3816	5906
15	3500	4200	6500
10	3500	4200	6500

Quando il carico radiale risultante non è applicato sulla mezzeria dell'albero occorre calcolare quello effettivo con la seguente formula:

When the resulting radial load is not applied on the centre line of the shaft it is necessary to calculate the effective load with the following formula:

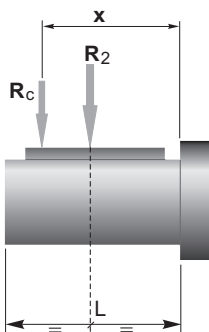

	CMB 402	CMB 502	CMB 633
a	86	104	118
b	66	79	93
R_{2MAX}	3500	4200	6500

$$R_c = \frac{R_2 \cdot a}{(b + x)} \leq R_{2MAX}$$

*a, b = valori riportati nella tabella
a, b = values given in the table*

$$R \leq R_c$$

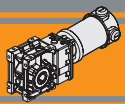

Dati tecnici per servizio S2

Technical data for S2 duty

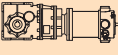
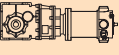
P_1 [W]	n_2 [min ⁻¹]	M_2 [Nm]	sf	i		Versione motore Motor version	P_1 [W]	n_2 [min ⁻¹]	M_2 [Nm]	sf	i		Versione motore Motor version
160							250						
(3000 min ⁻¹)	485	3.0	10.5	6.18	120/402	120/240	(3000 min ⁻¹)	485	4.6	6.7	6.18	180/402	120/240
	401	3.6	8.6	7.49									
	326	4.4	7.0	9.20									
	254	5.7	6.2	11.83									
	240	6.0	5.9	12.48									
	202	7.1	4.9	14.83									
	170	8.4	4.1	17.63									
	161	8.9	4.8	18.60									
	134	10	4.0	22.33									
	125	11	3.8	23.91									
	104	14	3.7	28.89									
	97	15	3.5	30.84									
	89	16	3.2	33.57									
	84	17	3.0	35.63									
	70	21	2.5	42.75									
	54	27	1.9	55.31									
	51	29	1.8	59.06									
	47	31	1.7	64.29									
	41	35	1.5	72.50									
	70	21	4.8	42.75	120/502	120/240		134	17	5.1	22.33	180/502	120/240
	54	27	3.7	55.31									
	51	28	3.5	59.06									
	47	31	3.2	64.29									
	41	35	2.8	72.50									
	41	35	5.5	73.96	120/633	120/240		52	43	4.5	57.93	180/633	120/240
	38	38	5.2	78.58									
	32	45	4.4	93.33									
	21	67	2.9	140.52									
	17	87	2.2	181.81									
	14	101	1.9	211.31									
	13	114	1.7	238.31									
							49	46	4.2	61.63			
							41	55	3.5	73.96			
							38	59	3.3	78.58			
							32	70	2.8	93.33			
							21	105	1.9	140.52			
							17	136	1.4	181.81			
							14	158	1.2	211.31			
							13	178	1.1	238.31			

NOTA: per servizio continuo o altamente intermittente, contattare il servizio tecnico

NOTE: for continuous or highly intermittent duty, please contact our technical service

Motori applicabili

Motor adapters

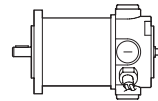
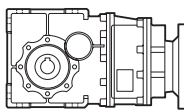

		ND	
		120.120 120.240	180.120 180.240
CMB	402	6.18 - 72.50	
	502	6.18 - 72.50	
	633	6.58 - 238.31	

Rapporti di riduzione i
Ratio i

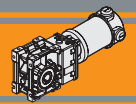

Dimensioni

Dimensions

NDCMB120/402 U
NDCMB180/402 U

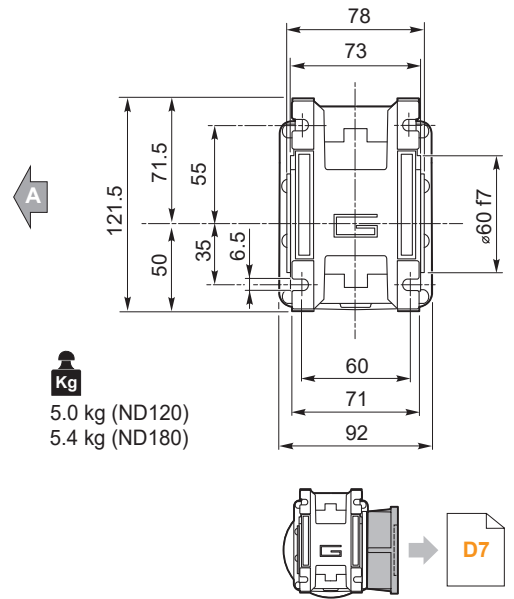
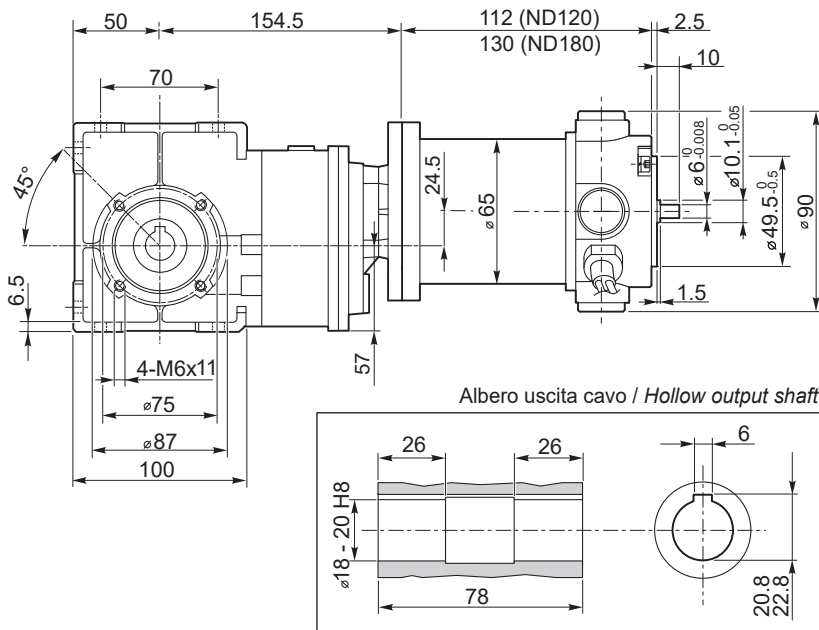

NDCMB120/502 U
NDCMB180/502 U

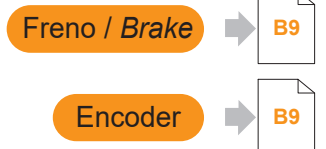
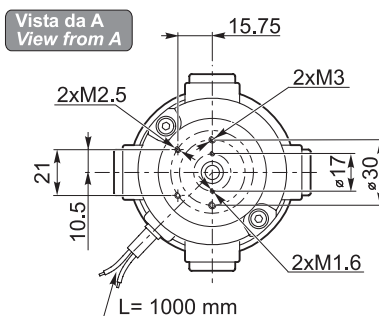
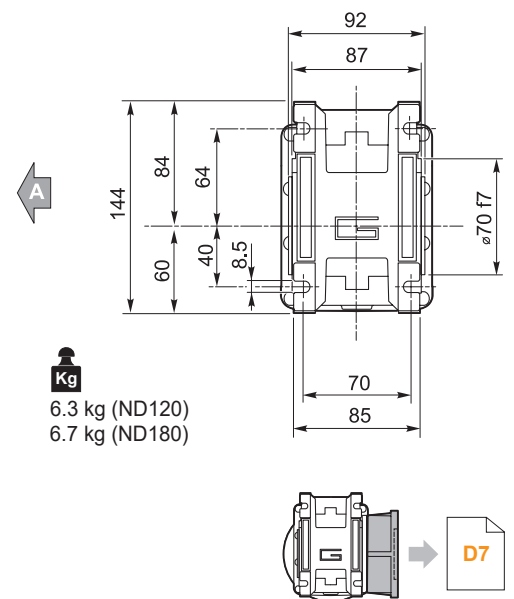
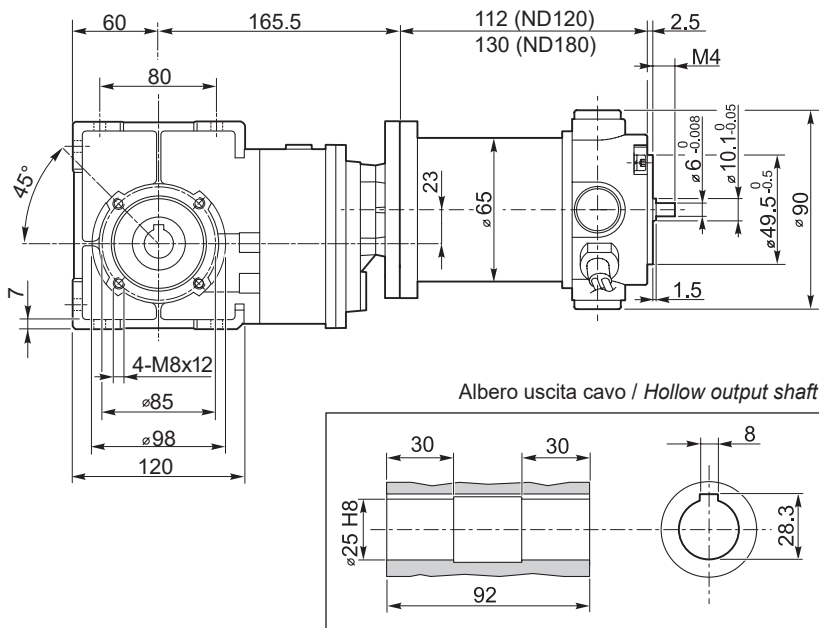

NDCMB

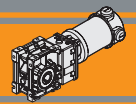

Dimensioni

Dimensions

NDCMB.../... F... Flange uscita / Output flanges

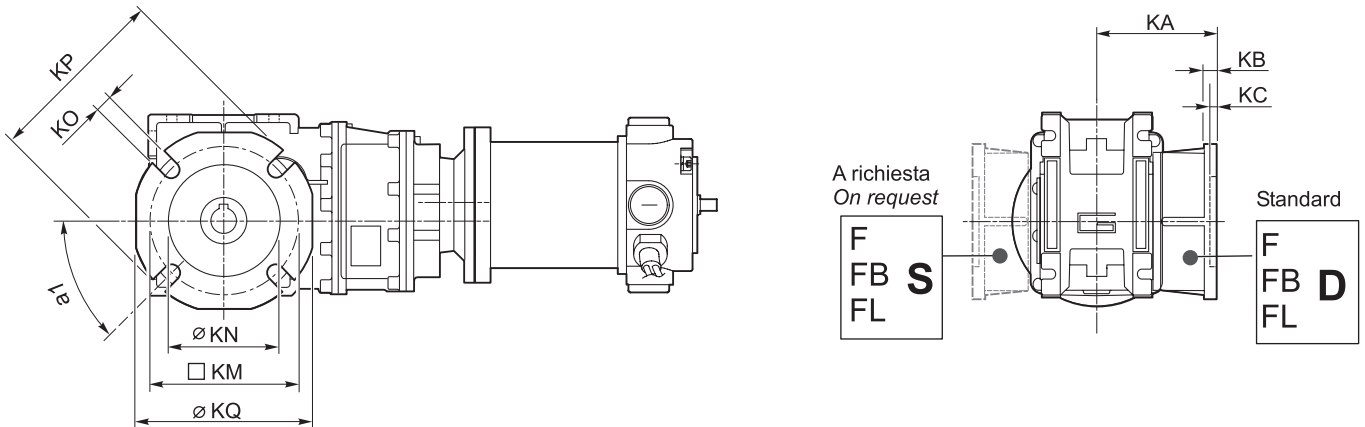

NDCMB

CMB	Flange uscita / Output flanges																										
	F									FL									FB								
	a ₁	KA	KB	KC	KM	KN H8	KO	KP	KQ	a ₁	KA	KB	KC	KM	KN H8	KO	KP	KQ	a ₁	KA	KB	KC	KM	KN H8	KO	KP	KQ
402	45°	67	7.5	4.5	80-95	60	9	110	95	45°	97	7.5	4.5	80-95	60	9	110	95	45°	80	8.5	5	115-125	95	9.5	140	112
502	45°	90	9	5	90-110	70	11	125	110	45°	120	9	5	90-110	70	11	125	110	45°	89	9	5	130-145	110	9.5	160	132
633	45°	82	10	6	150 - 160	115	11	180	142	45°	112	10	8	150 - 160	115	11	180	142	45°	98	11	5	165	130	11	200	160

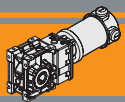

Accessori

Accessories

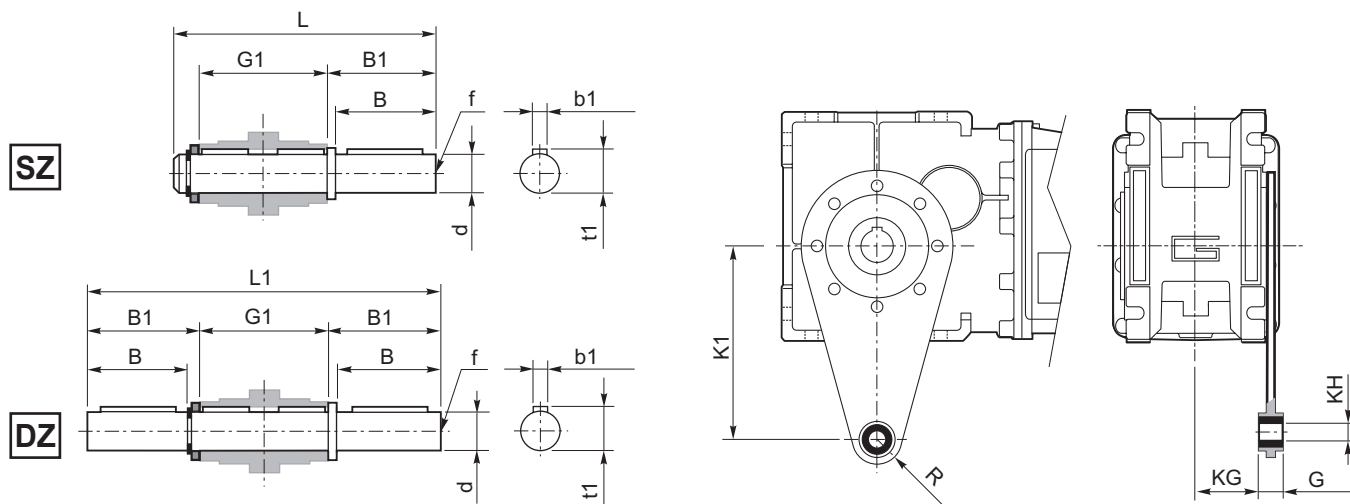

Albero lento / Output shaft

CMB	d h7	B	B1	G1	L	L1	f	b1	t1
402	18	40	43	78	128	164	M6	6	20.5
502	25	50	53.5	92	153	199	M10	8	28
633	25	50	53.5	112	173	219	M10	8	28

Braccio di reazione / Torque arm

CMB	K1	G	KG	KH	R
402	100	14	31	10	18
502	100	14	38	10	18
633	150	14	47.5	10	18

SC - Safety cover

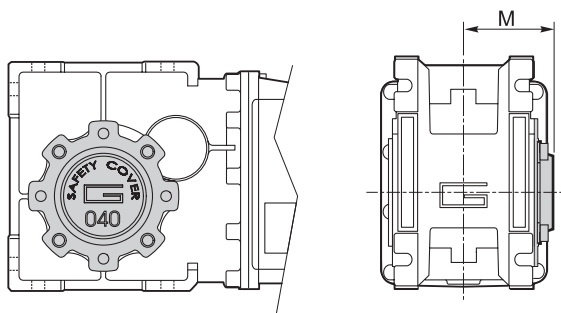

CMB	M
402	54.5
502	62.5
633	73



Neodymium

Motoriduttori CC pendolari
DC helical parallel gearmotors



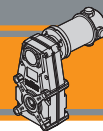

Indice	Index	Pag. Page
Caratteristiche tecniche	<i>Technical features</i>	E2
Designazione	<i>Classification</i>	E2
Sensi di rotazione	<i>Direction of rotation</i>	E3
Simbologia	<i>Symbols</i>	E3
Lubrificazione	<i>Lubrication</i>	E3
Carichi radiali	<i>Radial loads</i>	E4
Dati tecnici	<i>Technical data</i>	E5
Motori applicabili	<i>Motor adapters</i>	E5
Dimensioni	<i>Dimensions</i>	E6

Questa sezione annulla e sostituisce ogni precedente edizione o revisione. Qualora questa sezione non Vi sia giunta in distribuzione controllata, l'aggiornamento dei dati ivi contenuto non è assicurato. **In tal caso la versione più aggiornata è disponibile sul nostro sito internet www.transtecno.com**

*This section replaces any previous edition and revision. If you obtained this catalogue other than through controlled distribution channels, the most up to date content is not guaranteed. **In this case the latest version is available on our web site www.transtecno.com***



NDFT Motoriduttori CC pendolari DC Helical parallel gearmotors

Caratteristiche tecniche

Technical features

I motoriduttori CC pendolari a magneti permanenti in neodimio NDFT hanno le seguenti caratteristiche principali:

NDFT neodymium permanent magnets DC helical parallel gearmotors range has the following main features:

- Alimentazione in bassa tensione 12/24 Vcc
- Possibilità di montaggio encoder e freno
- Potenze motore disponibili da 160 a 250W S2
- Magneti in Neodimio
- Carcasse dei riduttori in pressofusione di alluminio
- Lubrificazione permanente con olio sintetico
- Ingranaggi cilindrici a denti elicoidali.

- Low voltage power supply 12/24 Vdc
- Suitable for encoder and brake assembly
- Motor power ratings available from 160 to 250W S2
- Neodymium magnets
- Die-cast aluminum housing
- Permanent synthetic oil long-life lubrication
- helical gears.

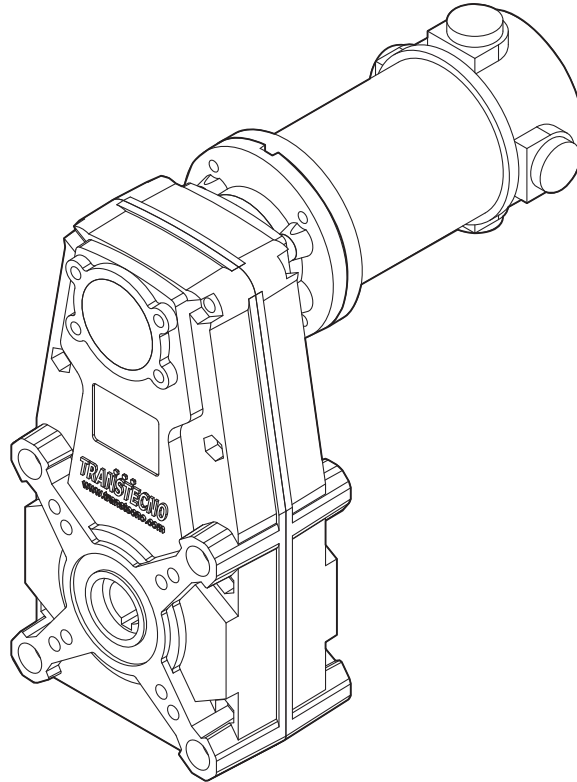

Designazione

Classification

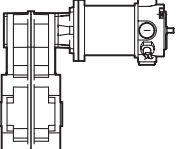
MOTORIDUTTORE / GEARMOTOR						
NDFT	120/146		U	60.63	O20	240
Tipo Type	Grandezza Size		Versione Riduttore Gearbox Version	Rapporto Ratio	Albero di uscita Output shaft	Versione Motore Motor Version
NDFT 	120/105/3 120/105/4 120/146	180/105/3 180/146	U...	Vedere tabella See tables	Vedere tabella See tables	120 240

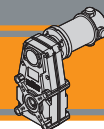

Sensi di rotazione

Direction of rotation

FT105/3
FT146

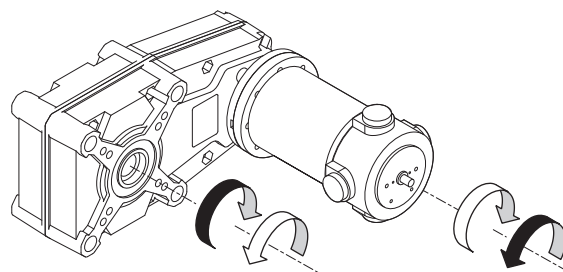
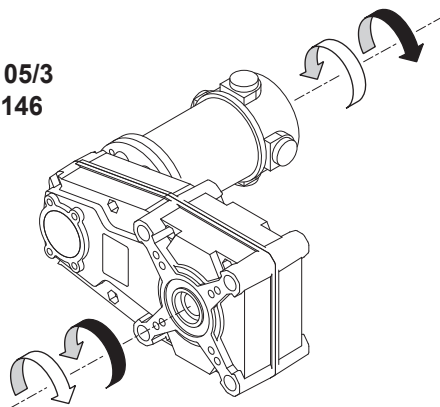

FT105/4

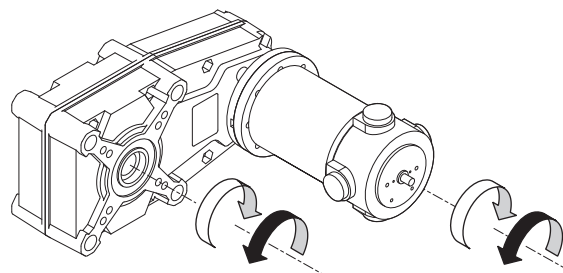
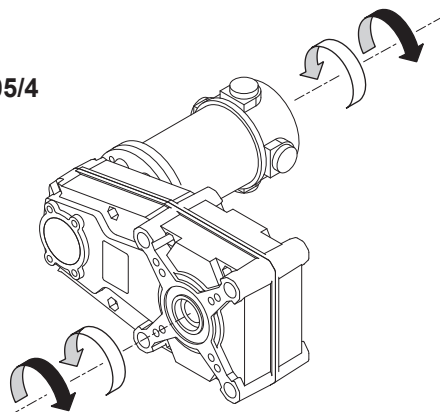

NDFT

Simbologia

Symbols

n_1	[min ⁻¹]	Velocità in ingresso / <i>Input speed</i>
n_2	[min ⁻¹]	Velocità in uscita / <i>Output speed</i>
i		Rapporto di riduzione / <i>Ratio</i>
P_1	[kW]	Potenza in entrata / <i>Input power</i>
M_2	[Nm]	Coppia nominale in uscita in funzione di P_1 / <i>Output torque referred to P_1</i>
P_{n1}	[kW]	Potenza nominale in entrata / <i>Nominal input power</i>
M_{n2}	[Nm]	Coppia nominale in uscita in funzione di P_{n1} / <i>Nominal output torque referred to P_{n1}</i>
sf		Fattore di servizio / <i>Service factor</i>
R_2	[N]	Carico radiale ammissibile in uscita / <i>Permitted output radial load</i>
A_2	[N]	Carico assiale ammissibile in uscita / <i>Permitted output axial load</i>

Lubrificazione

Lubrication

Tutti i motoriduttori sono forniti completi di lubrificante sintetico viscosità 320, pertanto possono essere installati in qualunque posizione di montaggio e non necessitano di manutenzione.

Permanent synthetic oil long-life lubrication (viscosity grade 320) makes it possible to use the gearmotors in all mounting positions; for this reason they can be installed in any assembly position and do not require maintenance.



Carichi radiali

Radial loads

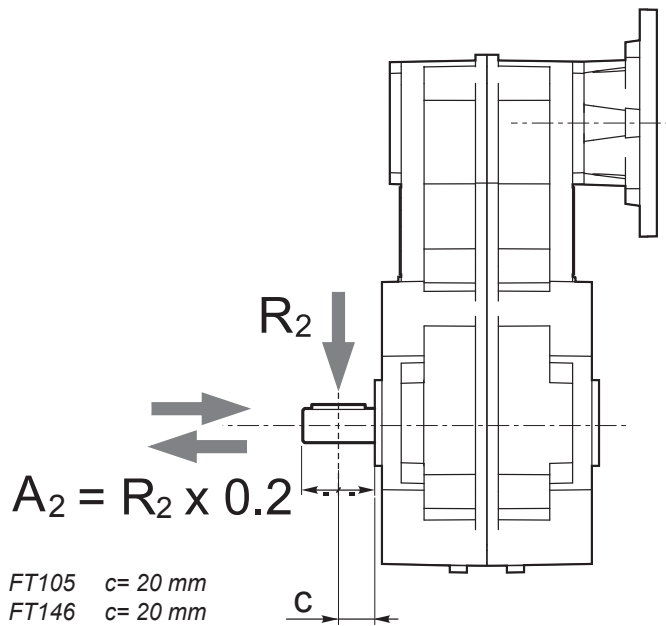

n_2 [min ⁻¹]	R_2 [N]	
	FT105	FT146
70	1500	2500
40	1700	2700
30	1850	2850
20	2000	3000
10	2000	3000
5	2000	3000

Quando il carico radiale risultante non è applicato sulla mezza-
ria dell'albero occorre calcolare quello effettivo con la seguente
formula:

When the resulting radial load is not applied on the centre line
of the shaft it is necessary to calculate the effective load with the
following formula:

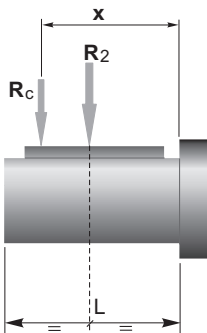

	FT105	FT146
a	82	82,5
b	62	62,5
R_{2MAX}	2000	3000

$$R_c = \frac{R_2 \cdot a}{(b+x)} \leq R_{2MAX}$$

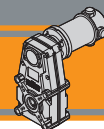

*a, b = valori riportati nella tabella
a, b = values given in the table*

$$R \leq R_c$$



Dati tecnici

Technical data

P_1 [W]	n_2 [min ⁻¹]	M_2 [Nm]	sf	i		Versione motore Motor version	P_1 [W]	n_2 [min ⁻¹]	M_2 [Nm]	sf	i		Versione motore Motor version		
160							250								
(3000 min ⁻¹)	146	10	3.2	20.57	120/105/3	120/240	(3000 min ⁻¹)	146	15	2.0	20.57	180/105/3	120/240		
	90	16	2.4	33.32				90	25	1.6	33.32				
	68	21	2.4	44.36				68	33	1.5	44.36				
	55	26	1.9	54.87				55	41	1.2	54.87				
	42	34	1.5	71.84				42	54	0.9	71.84				
	39	37	1.4	77.07				39	58	0.9	77.07				
	34	43	1.2	88.87				34	66	0.8	88.87				
	24	60	0.8	124.81											
	17	86	0.6	181.35				160	14	4.4	18.75			180/146	120/240
	13	86	0.6	224.32				115	20	3.2	26.17				
	9.5	86	0.6	315.05		106	21	3.0	28.26						
						86	26	3.0	35.07						
	8.1	86	0.6	368.19	120/105/4	120/240	76	30	2.6	39.44					
	5.6	86	0.6	534.98				65	35	2.2	46.44				
	4.5	86	0.6	661.76				57	40	2.0	52.86				
	3.2	86	0.6	929.40				49	45	1.9	60.63				
	160	9	7.0	18.75	120/146	120/240	43	52	1.6	70.00					
	115	13	5.0	26.17				35	63	1.4	84.63				
	106	14	4.6	28.26				31	72	1.2	95.61				
	86	17	4.6	35.07				26	85	1.0	113.40				
	76	19	4.1	39.44				22	100	0.9	133.45				
	65	22	3.5	46.44				20	112	0.8	150.18				
	57	25	3.1	52.86				19	120	0.8	160.43				
	49	29	3.0	60.63				17	134	0.7	178.83				
	43	34	2.6	70.00											
	35	41	2.1	84.63											
	31	46	1.9	95.61											
	26	54	1.6	113.40											
	22	64	1.3	133.45											
	20	72	1.2	150.18											
	19	77	1.2	160.43											
	17	86	1.1	178.83											
	13	107	0.9	223.92											
	13	113	0.8	236.83											
	10	134	0.7	300.07											
	7.5	134	0.7	397.38											

N.B.

Verificare sempre che la coppia M_2 utilizzata non ecceda il valore indicato nelle caselle in grigio

N.B.

Please check that the output torque M_2 does not exceed the value in the grey areas

NOTA: per servizio continuo o altamente intermittente, contattare il servizio tecnico

NOTE: for continuous or highly intermittent duty, please contact our technical service

Motori applicabili

Motor adapters

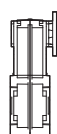
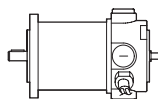

		ND	
		120.120 120.240	180.120 180.240
FT	105/3	20.57 - 315.05	20.57 - 315.05
	105/4	368.19 - 929.4	368.19 - 929.4
	146	18.75 - 397.38	18.75 - 397.38

18.75 - 397.38

Rapporti di riduzione i
Ratio i



Dimensioni

Dimensions

NDFT 180/105

NDFT 180/105...U

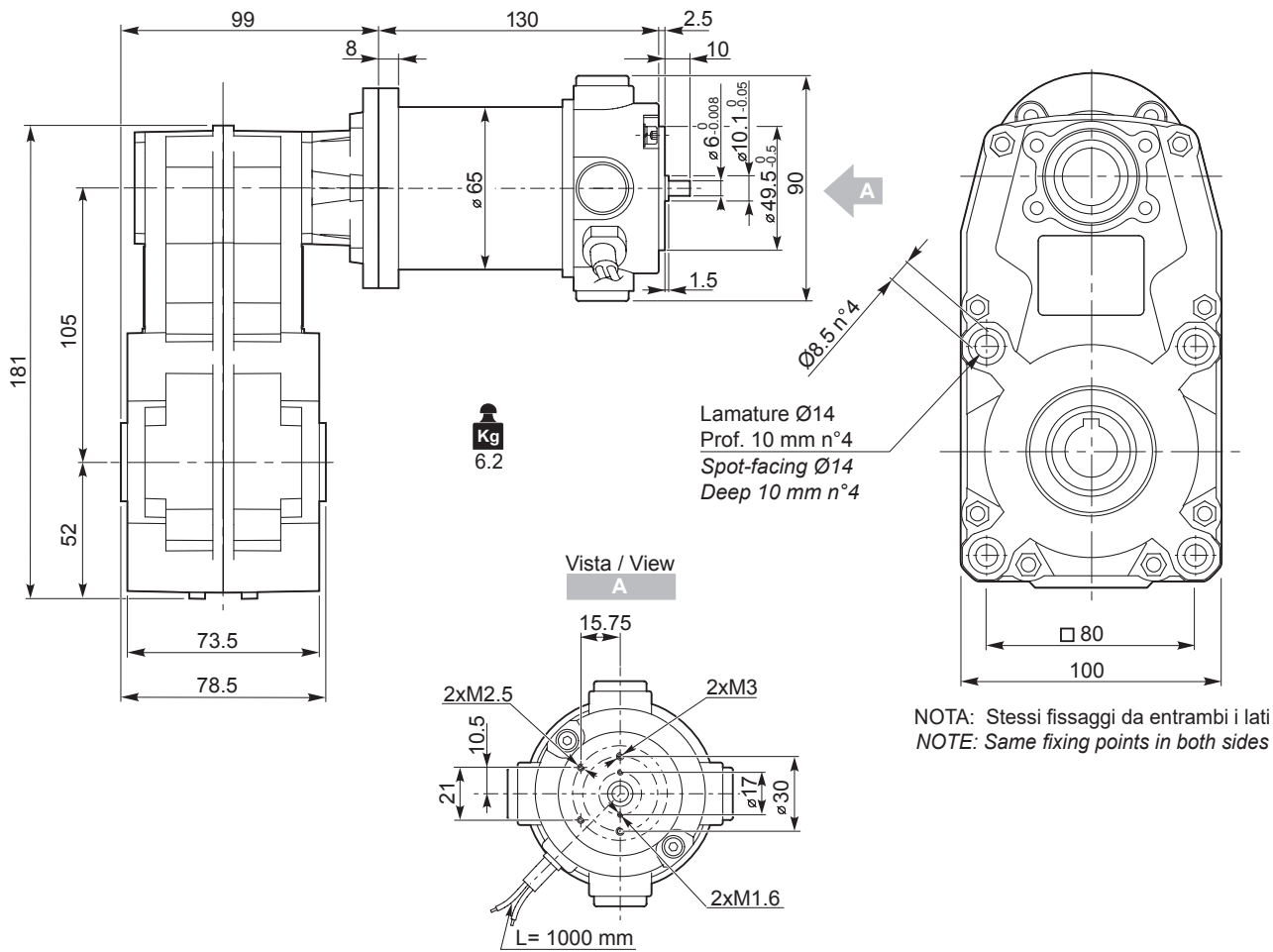

NDFT

O17

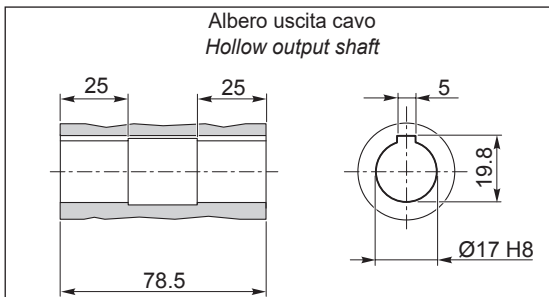

O20

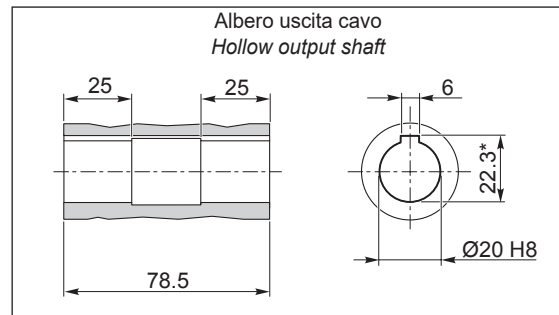

*: Sede linguetta ribassata / Special keyway

Freno / Brake



B9

Encoder



B9

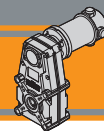

Dimensioni

Dimensions

NDFT 180/146

NDFT 180/146...U

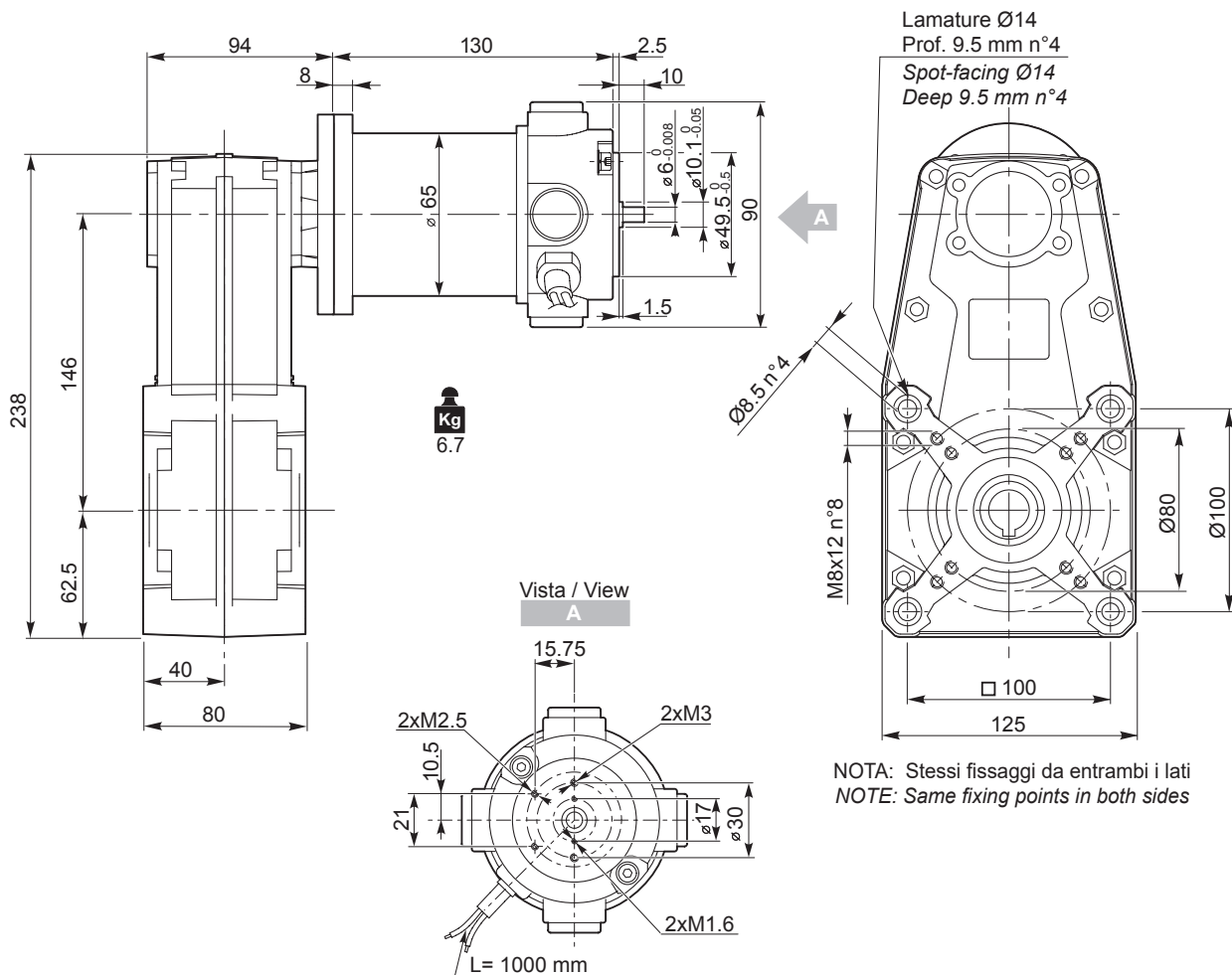

O20

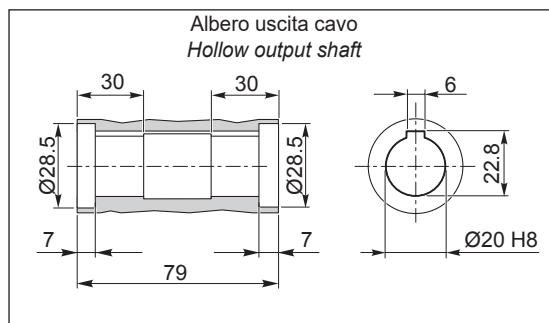

- Freno / Brake → B9
- Encoder → B9



Neodymium

Motoriduttori CC a vite senza fine
DC wormgearmotors



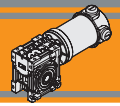

Indice	Index	Pag. Page
Caratteristiche tecniche	<i>Technical features</i>	F2
Designazione	<i>Classification</i>	F2
Simbologia	<i>Symbols</i>	F2
Lubrificazione	<i>Lubrication</i>	F3
Carichi radiali	<i>Radial loads</i>	F3
Dati di dentatura	<i>Toothing data</i>	F4
Rendimento	<i>Efficiency</i>	F4
Dati tecnici	<i>Technical data</i>	F5
Motori applicabili	<i>IEC Motor adapters</i>	F5
Dimensioni	<i>Dimensions</i>	F6
Opzioni	<i>Options</i>	F10
Accessori	<i>Accessories</i>	F10

Questa sezione annulla e sostituisce ogni precedente edizione o revisione. Qualora questa sezione non Vi sia giunta in distribuzione controllata, l'aggiornamento dei dati ivi contenuto non è assicurato. **In tal caso la versione più aggiornata è disponibile sul nostro sito internet www.transtecno.com**

This section replaces any previous edition and revision. If you obtained this catalogue other than through controlled distribution channels, the most up to date content is not guaranteed. In this case the latest version is available on our web site www.transtecno.com

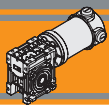

Caratteristiche tecniche

Technical features

Le caratteristiche principali dei motoriduttori CC a vite senza fine a magneti permanenti in neodimio NDCM sono:

The main features of NDCM neodymium permanent magnets DC wormgearmotors range are:

- Alimentazione in bassa tensione 12/24 Vcc
- Possibilità di montaggio encoder e freno
- Potenze motore disponibili da 160 a 250 W S2
- Magneti in Neodimio
- Carcasse dei riduttori a vite senza fine in pressofusione di alluminio
- Lubrificazione permanente con olio sintetico
- Low voltage power supply 12/24 Vdc
- Suitable for encoder and brake assembly
- Motor power ratings available from 160 to 250 W S2
- Neodymium magnets
- Die-cast aluminum housing on wormgearboxes
- Permanent synthetic oil long-life lubrication

Designazione

Classification

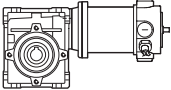
MOTORIDUTTORE / GEARMOTOR									
NDCM	120/030		U	10	SZDX	BRSX	90	240	VS
Tipo Type	Grandezza Size		Versione Riduttore Gearbox Version	Rapporto Ratio	Albero di uscita Output shaft	Braccio di reazione Torque arm	Angolo Angle	Versione Motore Motor Version	Opzioni Options
	120/026	180/026	U F...	Vedere tabella See tables	SZDX SZSX DZ	BRDX BRSX	0° 90° 180° 270°	120 — 240	VS
	120/026 (D11)	180/026 (D11)							
	120/026 (D14)	180/026 (D14)							
	120/030	180/030							
	120/040	180/040							

Versione Riduttore
Gearbox Version

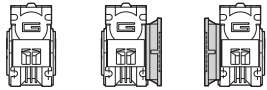

U F...D F...S

Albero di uscita
Output shaft

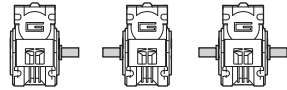

SZDX SZSX DZ

Braccio di reazione
Torque arm *

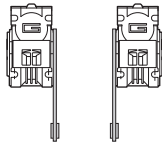

BRDX BRSX

Angolo
Angle

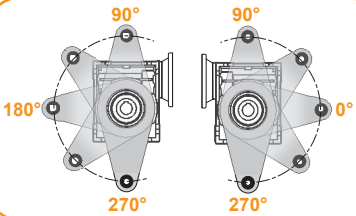

90° 90°
180° 0°
270° 270°

* NOTA: il braccio di reazione viene fornito smontato.
NOTE: the torque arm will be supplied not assembled.

Simbologia

Symbols

n_1 [min ⁻¹]	Velocità in ingresso / Input speed	R_d %	Rendimento dinamico / Dynamic efficiency
n_2 [min ⁻¹]	Velocità in uscita / Output speed	A_2 [N]	Carico assiale ammissibile in uscita / Permitted output axial load
i	Rapporto di riduzione / Ratio	R_s %	Rendimento statico / Static efficiency
P_1 [kW]	Potenza in entrata / Input power	R_2 [N]	Carico radiale ammissibile in uscita / Permitted output radial load
M_2 [Nm]	Coppia in uscita in funzione di P_1 / Output torque referred to P_1	Z	Numero di principi della vite / Worm starts
sf	Fattore di servizio / Service factor	β	Angolo d'elica / Helix angle

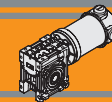

Lubrificazione

Lubrication

I riduttori a vite senza fine della serie CM sono lubrificati a vita con olio sintetico di viscosità 320 e possono essere installati in qualunque posizione di montaggio.

Permanent synthetic oil long-life lubrication allow to use CM wormgearbox range in all mounting position.

Carichi radiali

Radial loads

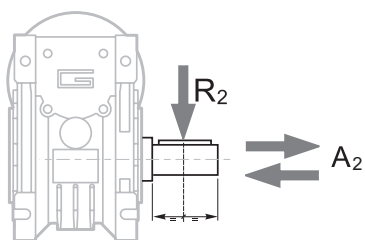

$A_2 = R_2 \times 0.2$

n_2 [min ⁻¹]	R_2 [N]		
	CM026	CM030	CM040
187	400	674	1264
140	490	743	1392
93	580	851	1596
70	610	936	1754
56	610	1008	1890
47	610	1069	2004
35	610	1179	2210
28	610	1270	2381
23	610	1356	2542
18	610	1471	2759
14	610	1600	3000

Quando il carico radiale risultante non è applicato sulla mezzeria dell'albero occorre calcolare quello effettivo con la seguente formula:

When the resulting radial load is not applied on the centre line of the shaft it is necessary to calculate the effective load with the following formula:

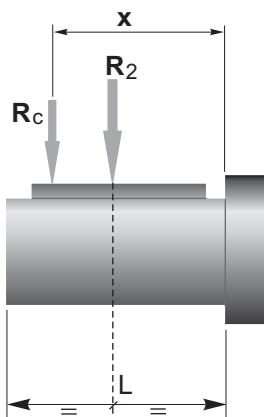

$$R_c = \frac{R_2 \cdot a}{(b+x)} \leq R_{2MAX}$$

$$R \leq R_c$$

a, b = valori riportati nella tabella
 a, b = values given in the table

	CM		
	026	030	040
a	56	65	84
b	43	50	64
R_{2MAX}	610	1600	3000

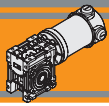

Dati di dentatura

Toothing data

	Dati della coppia vite-corona Worm wheel data	Rapporto / Ratio											
		5	7.5	10	15	20	25	30	40	50	60	80	100
CM026	Z	6	4	3	2	2		1	1	1	1		
	β	34° 35'	24° 41'	19° 1'	12° 57'	10° 30'		6° 33'	5° 17'	4° 26'	3° 49'		
CM030	Z	6	4	3	2	2	2	1	1	1	1	1	1
	β	27° 4'	24° 28'	18° 50'	12° 49'	10° 23'	8° 43'	6° 29'	5° 14'	4° 23'	3° 46'	2° 57'	2° 25'
CM040	Z	6	4	3	2	2	2	1	1	1	1	1	1
	β	34° 19'	24° 28'	18° 50'	12° 49'	10° 23'	8° 43'	6° 29'	5° 14'	4° 23'	3° 46'	2° 57'	2° 25'

Rendimento

Efficiency

	n_1 [min ⁻¹]	Rendimento Efficiency	Rapporto / Ratio											
			5	7.5	10	15	20	25	30	40	50	60	80	100
CM026	2800	Rd	89	87	85	83	80		73	68	64	60		
	1400		87	84	83	78	74		66	61	57	53		
	900		84	83	80	75	71		61	57	52	48		
			Rs	72	71	68	61	56		46	41	36	34	
CM030	2800	Rd	89	88	86	84	81	78	74	70	65	62	57	52
	1400		86	85	84	79	75	72	67	62	58	55	48	43
	900		84	83	81	75	71	68	62	58	53	49	43	39
			Rs	72	67	63	55	50	43	39	35	31	27	23
CM040	2800	Rd	90	89	87	84	83	80	77	73	69	66	60	56
	1400		88	86	84	81	78	74	70	65	60	58	52	46
	900		86	84	82	77	74	70	66	60	57	53	46	41
			Rs	74	71	67	60	55	51	45	40	36	32	28



Rendimento teorico del riduttore dopo il rodaggio
Theoretical efficiency of the gearbox after the first running period

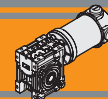

Dati tecnici per servizio S2

Technical data for S2 duty

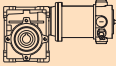
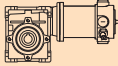
P ₁ [W]	n ₂ [min ⁻¹]	M ₂ [Nm]	sf	i		Versione motore Motor version	P ₁ [W]	n ₂ [min ⁻¹]	M ₂ [Nm]	sf	i		Versione motore Motor version
160							250						
(3000 min ⁻¹)	600	2	4.4	5	120/026	120/240	(3000 min ⁻¹)	600	4	2.8	5	180/026	120/240
	400	3	3.3	7.5	120/026			400	5	2.1	7.5	180/026	
	300	4	2.5	10	120/026			300	7	1.6	10	180/026	
	200	6	1.7	15	120/026			200	10	1.1	15	180/026	
	150	8	1.3	20	120/026			150	13	0.9	20	180/026	
	100	11	1.1	30	120/026			100	17	0.7	30	180/026	
	75	14	0.8	40	120/026			75	16	0.7	40	180/026	
	60	14	0.7	50	120/026			60	14	0.7	50	180/026	
	50	13	0.7	60	120/026			50	13	0.7	60	180/026	
	600	2	5.7	5	120/030	120/240		600	4	3.7	5	180/030	120/240
	400	3	4.5	7.5	120/030			400	5	2.9	7.5	180/030	
	300	4	3.7	10	120/030			300	7	2.3	10	180/030	
	200	6	2.5	15	120/030			200	10	1.6	15	180/030	
	150	8	1.7	20	120/030			150	13	1.1	20	180/030	
	120	10	1.5	25	120/030			120	16	1.0	25	180/030	
	100	11	1.6	30	120/030			100	18	1.0	30	180/030	
	75	14	1.1	40	120/030			75	22	0.7	40	180/030	
	60	17	0.9	50	120/030			60	21	0.7	50	180/030	
	50	20	0.7	60	120/030			50	20	0.7	60	180/030	
	38	17	0.7	80	120/030			38	17	0.7	80	180/030	
	30	16	0.7	100	120/030			30	16	0.7	100	180/030	
	150	8	3.7	20	120/040	120/240		600	4	8.1	5	180/040	120/240
	120	10	2.7	25	120/040			400	5	5.8	7.5	180/040	
	100	12	3.2	30	120/040			300	7	4.8	10	180/040	
	75	15	2.3	40	120/040			200	10	3.5	15	180/040	
	60	18	1.8	50	120/040			150	13	2.3	20	180/040	
	50	20	1.4	60	120/040			120	16	1.8	25	180/040	
	38	24	1.1	80	120/040			100	18	2.1	30	180/040	
	30	29	0.8	100	120/040			75	23	1.5	40	180/040	
								60	27	1.2	50	180/040	
								50	32	0.9	60	180/040	
								38	38	0.7	80	180/040	
								30	34	0.7	100	180/040	

N.B.
Verificare sempre che la coppia M₂ utilizzata non ecceda il valore indicato nelle caselle in grigio

N.B.
Please check that the output torque M₂ does not exceed the value in the grey areas

NOTA: per servizio continuo o altamente intermittente, contattare il servizio tecnico

NOTE: for continuous or highly intermittent duty, please contact our technical service

Motori applicabili

IEC Motor adapters

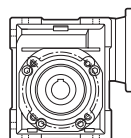
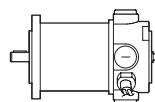

		ND	
		120.120 120.240	180.120 180.240
CM	026	5 - 60	5 - 60
	030	5 - 100	5 - 100
	040	5 - 100	5 - 100

5-100

Rapporti di riduzione i
Ratio i

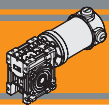

Dimensioni

Dimensions

NDCM120/026 U

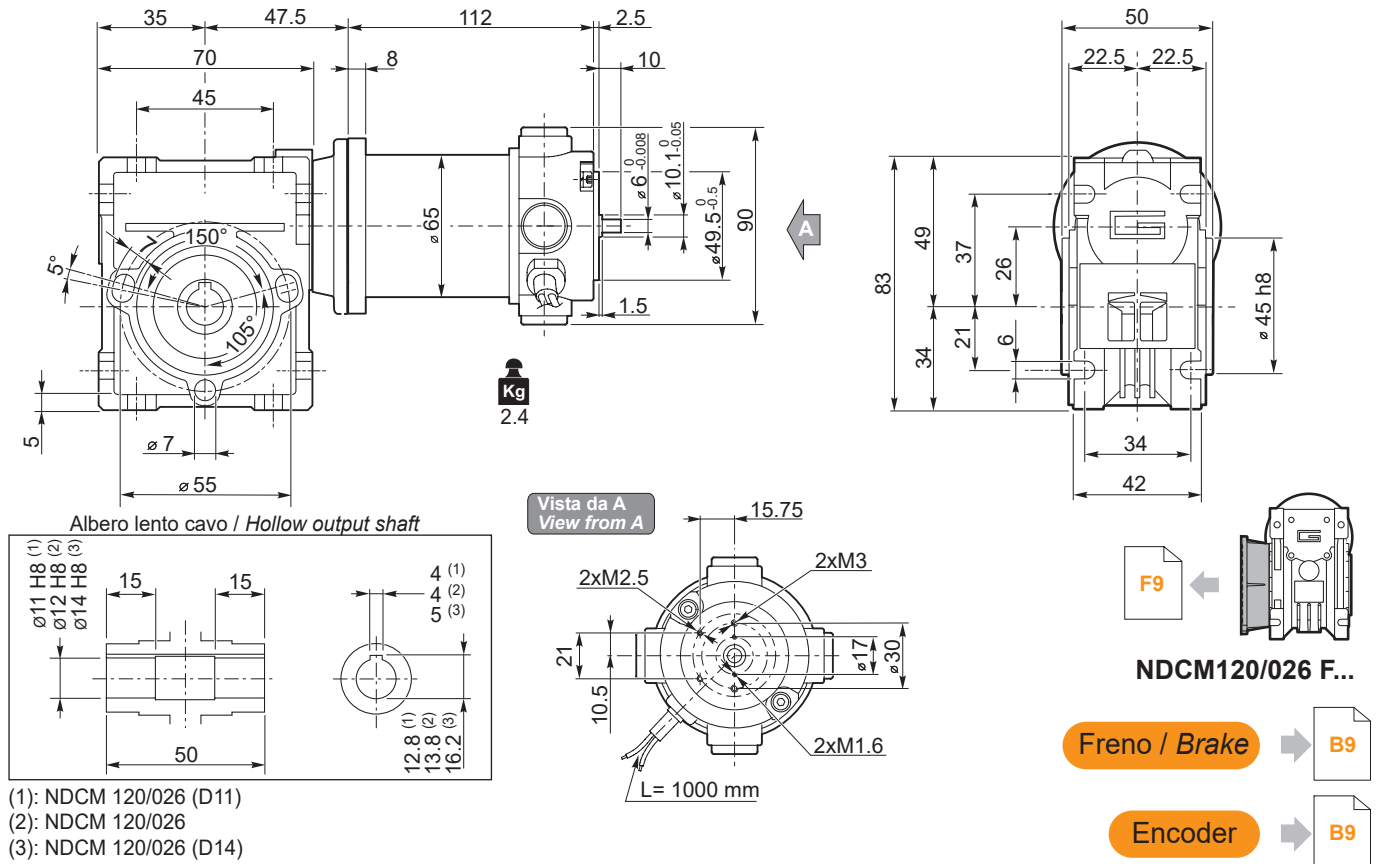

NDCM120/030 U

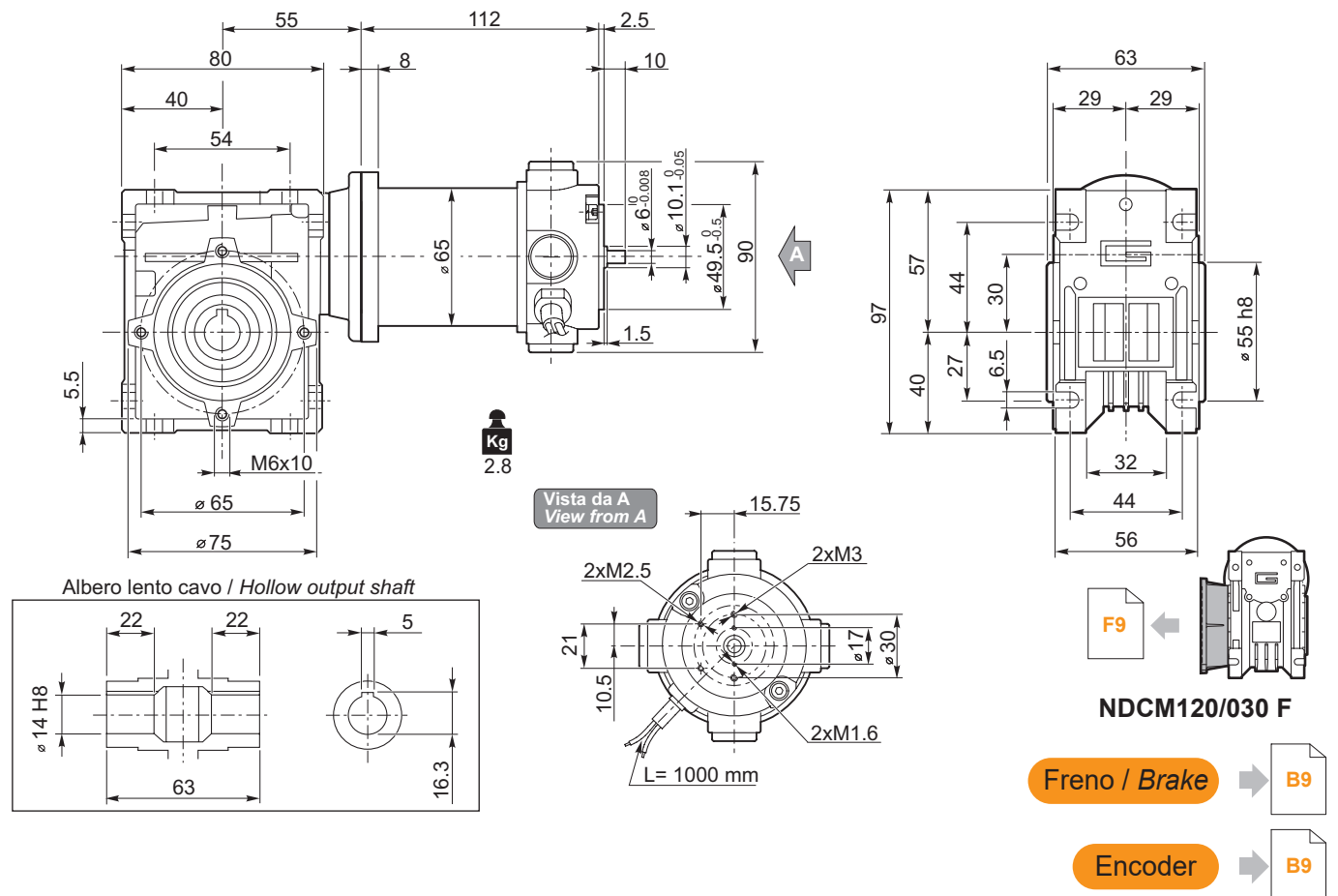

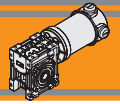

Dimensioni

Dimensions

NDCM180/040 U

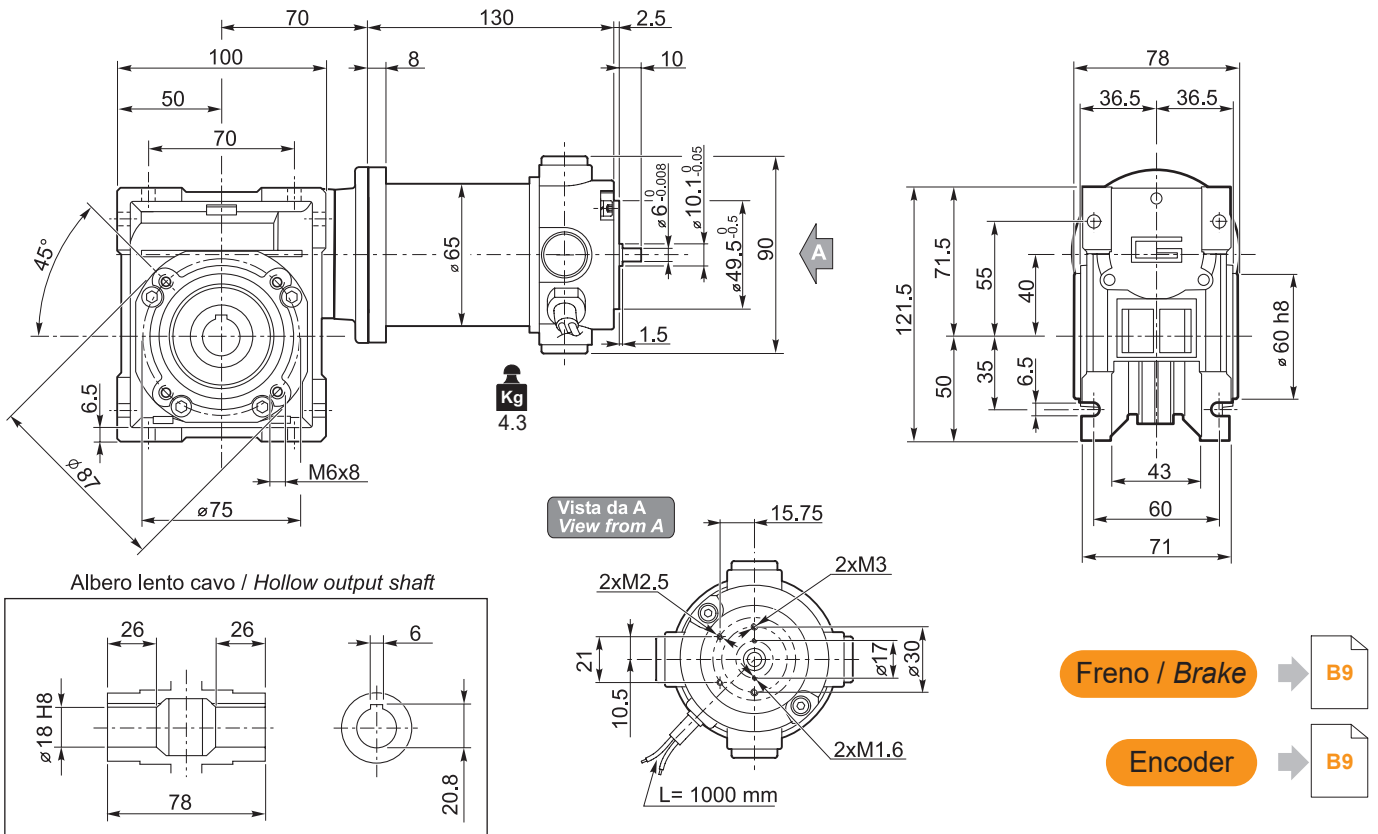

NDCM

NDCM.../... F... Flange uscita / Output flanges

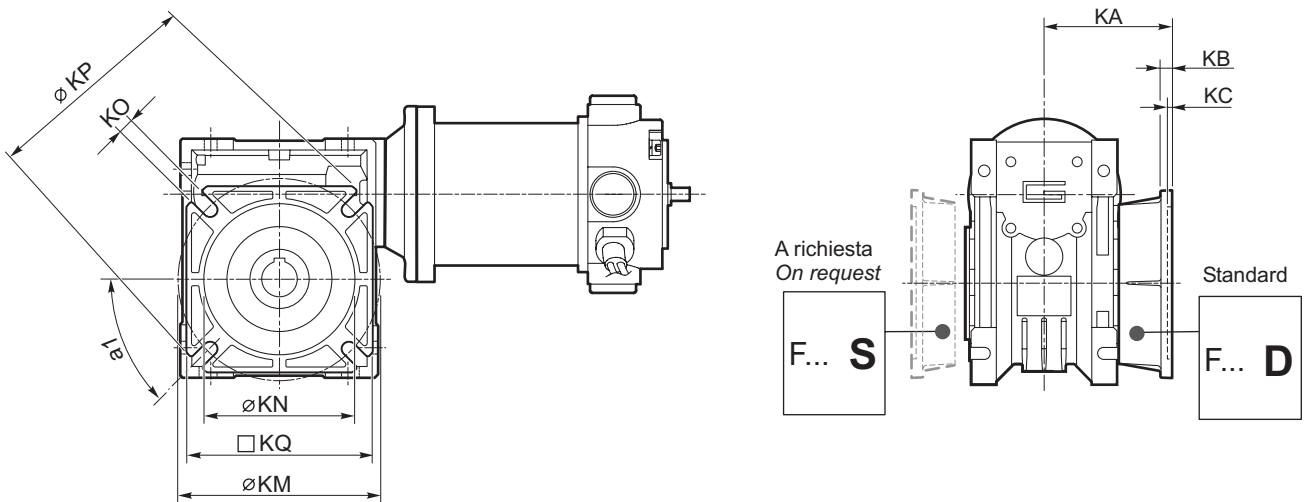

	CM..F							CM..F28							CM..F30										
	a1	KA	KB	KC	KM	KN _{H8}	KO	KP	KQ	KA	KB	KC	KM	KN _{H8}	KO	KP	KQ	KA	KB	KC	KM	KN _{H8}	KO	KP	KQ
026 (D11)	45°	45	6	4.5	55-69	40	6.5(n.4)	75	70	44	6.5	5	56-64	40	6.5	70	60	48	6.5	5	68	50	6.5	80	70
026 (D14)																									

	CM..F							CM..FB							CM..FL										
	a1	KA	KB	KC	KM	KN _{H8}	KO	KP	KQ	KA	KB	KC	KM	KN _{H8}	KO	KP	KQ	KA	KB	KC	KM	KN _{H8}	KO	KP	KQ
030	45°	54.5	6	4	68	50	6.5(n.4)	80	70	—	—	—	—	—	—	—	—	—	—	—	—	—	—	—	—
040	45°	67	7.5	4.5	80-95	60	9(n.4)	110	95	80	8.5	5	115-125	95	9.5(n.4)	140	112	97	7.5	4.5	80-95	60	10(n.4)	110	95



Opzioni

Options

VS - Vite sporgente / Extended input shaft

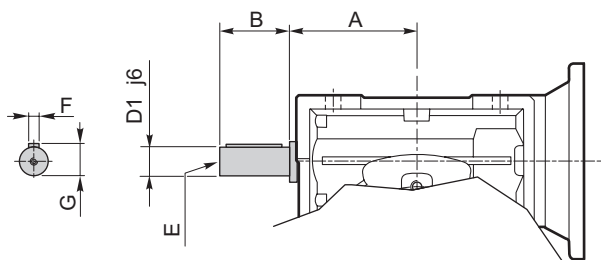

SC - Safety cover

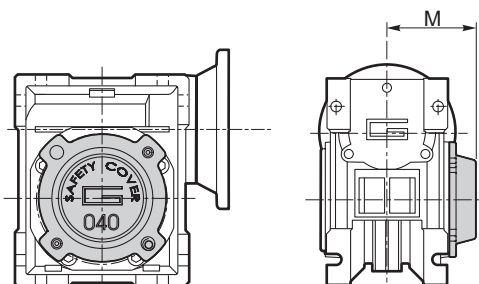

	A	B	D ₁ j6	E	F	G
CM 030	45	20	9	M4	3	10.2
CM 040	53	23	11	M5	4	12.5

	M
CM 030	47
CM 040	54.5

Costruito su richiesta
Built on request

Accessori

Accessories

Albero lento

Output shaft

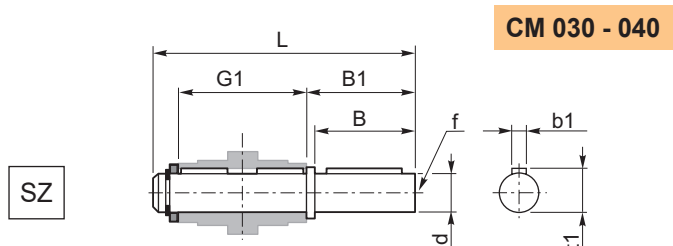
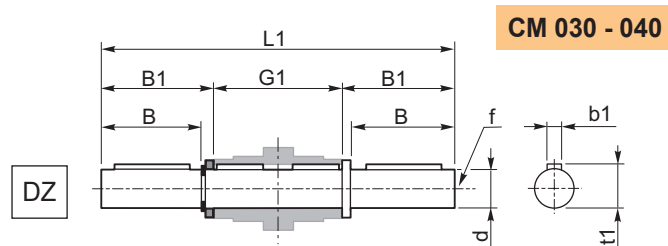

	d h7	B	B1	G1	L	L1	f	b1	t1
CM 030	14	30	32.5	63	102	128	M6	5	16
CM 040	18	40	43	78	128	164	M6	6	20.5

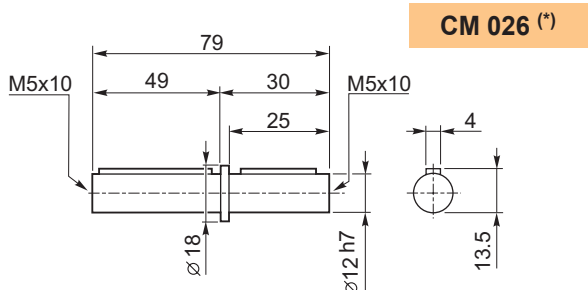

(*)
Nota: disponibile solo per cavo uscita Ø12
Note: available for output hollow shaft Ø12 only

Braccio di reazione

Torque arm

	K1	G	KG	KH	R
CM 030	85	14	23	8	15
CM 040	100	14	31	10	18

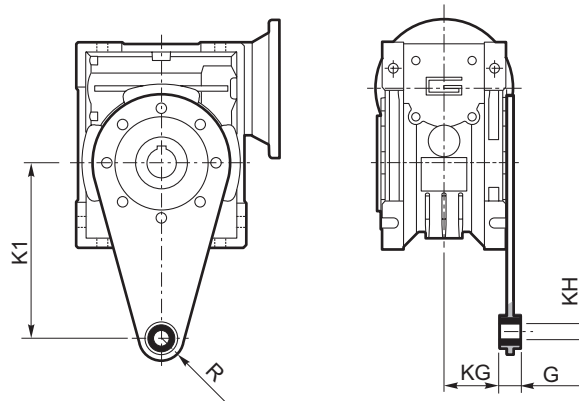



Neodymium

Motoriduttori CC a vite senza fine con precoppia DC pre stage wormgearmotors

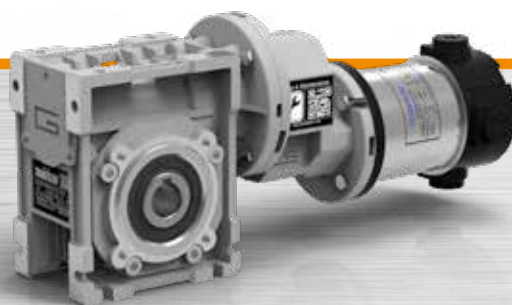

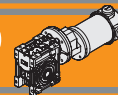

Indice	Index	Pag. Page
Caratteristiche tecniche	<i>Technical features</i>	G2
Designazione	<i>Classification</i>	G2
Simbologia	<i>Symbols</i>	G3
Lubrificazione	<i>Lubrication</i>	G3
Carichi radiali	<i>Radial loads</i>	G3
Dati tecnici	<i>Technical data</i>	G4
Motori applicabili	<i>IEC Motor adapters</i>	G4
Dimensioni	<i>Dimensions</i>	G5
Opzioni	<i>Options</i>	G8
Accessori	<i>Accessories</i>	G8

Questa sezione annulla e sostituisce ogni precedente edizione o revisione. Qualora questa sezione non Vi sia giunta in distribuzione controllata, l'aggiornamento dei dati ivi contenuto non è assicurato. **In tal caso la versione più aggiornata è disponibile sul nostro sito internet www.transtecno.com**

This section replaces any previous edition and revision. If you obtained this catalogue other than through controlled distribution channels, the most up to date content is not guaranteed. In this case the latest version is available on our web site www.transtecno.com

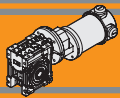

Caratteristiche tecniche

Technical features

Le caratteristiche principali dei motoriduttori CC a vite senza fine con precoppia a magneti permanenti in neodimio NDCMP sono:

The main features of NDCMP neodymium permanent magnets DC pre stage wormgearmotors range are:

- Alimentazione in bassa tensione 12/24 Vcc
- Possibilità di montaggio encoder e freno
- Potenze motore disponibili da 160 a 250 W S2
- Magneti in Neodimio
- Sia le carcasse dei riduttori a vite senza fine che delle precoppie sono in pressofusione di alluminio
- Lubrificazione permanente con olio sintetico.

- Low voltage power supply 12/24 Vdc
- Suitable for encoder and brake assembly
- Motor power ratings available from 160 to 250 W S2
- Neodymium magnets
- Die-cast aluminum housing on pre-stage and wormgearboxes
- Permanent synthetic oil long-life lubrication.

Designazione

Classification

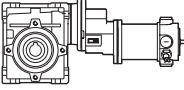
MOTORIDUTTORE / GEARMOTOR										
NDCMP	120/056/030		U	90	SZDX	BRSX	90	P4	240	VS
Tipo Type	Grandezza Size		Versione Riduttore Gearbox Version	Rapporto Ratio	Albero di uscita Output shaft	Braccio di reazione Torque arm	Angolo Angle	Pos. di montaggio precoppia Pre stage mounting position	Versione Motore Motor Version	Opzioni Options
	120/056/030	180/056/030	U FD FS FLD FLS FBD FBS	Vedere tabella <i>See tables</i>	SZDX SZSX DZ	BRDX BRSX *	0° 90° 180° 270°	P1 P2 P3 (standard) P4	120 — 240	VS
	120/056/040	180/056/040								

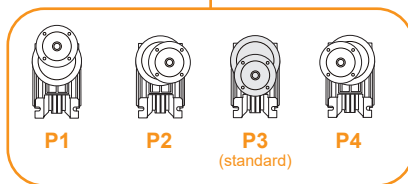

Versione Riduttore
Gearbox Version

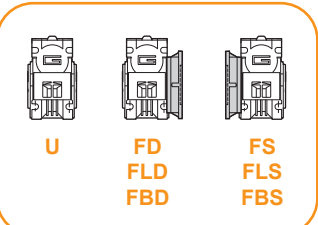

Albero di uscita
Output shaft

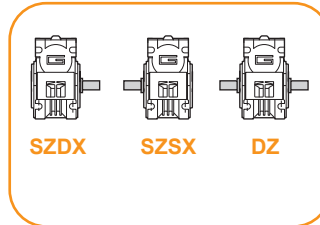

Braccio di reazione
Torque arm *

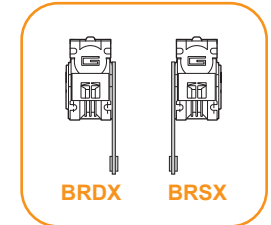

Angolo
Angle

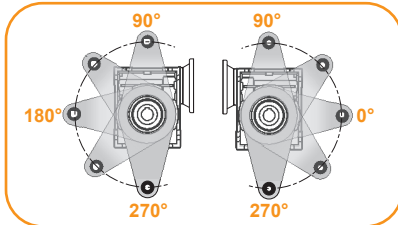

* NOTA: il braccio di reazione viene fornito smontato.
NOTE: the torque arm will be supplied not assembled.

Simbologia

Symbols

n_1 [min ⁻¹]	Velocità in ingresso / <i>Input speed</i>	M_2 [Nm]	Coppia in uscita in funzione di P_1 / <i>Output torque referred to P_1</i>
n_2 [min ⁻¹]	Velocità in uscita / <i>Output speed</i>	sf	Fattore di servizio / <i>Service factor</i>
i	Rapporto di riduzione / <i>Ratio</i>	R_2 [N]	Carico radiale ammissibile in uscita / <i>Permitted output radial load</i>
P_1 [kW]	Potenza in entrata / <i>Input power</i>	A_2 N]	Carico assiale ammissibile in uscita / <i>Permitted output axial load</i>

Lubrificazione

Lubrication

I riduttori a vite senza fine con precoppia della serie CMP sono lubrificati a vita con olio sintetico di viscosità 320 e possono essere installati in qualunque posizione di montaggio.

Permanent synthetic oil long-life lubrication allow to use CMP range in all mounting position.

NDCMP

Carichi radiali

Radial loads

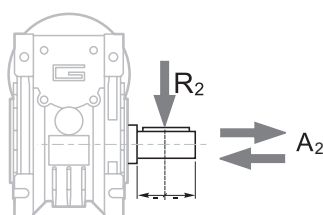

n_2 [min ⁻¹]	R_2 [N]	
	CM030	CM040
35	1179	2210
28	1270	2381
23	1356	2542
18	1471	2759
14	1600	3000

Quando il carico radiale risultante non è applicato sulla mezzeria dell'albero occorre calcolare quello effettivo con la seguente formula:

When the resulting radial load is not applied on the centre line of the shaft it is necessary to calculate the effective load with the following formula:

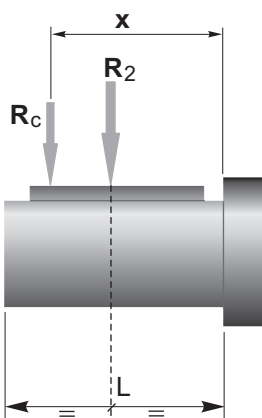

$$R_c = \frac{R_2 \cdot a}{(b + x)} \leq R_{2MAX}$$

$$R \leq R_c$$

a, b = valori riportati nella tabella
a, b = values given in the table

	CMP	
	030	040
a	65	84
b	50	64
R_{2MAX}	1600	3000

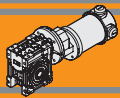

Dati tecnici per servizio S2

Technical data for S2 duty

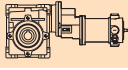
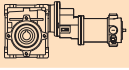
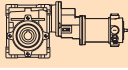
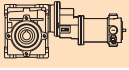
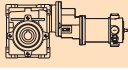
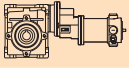
P_1 [W]	n_2 [min ⁻¹]	M_2 [Nm]	sf	i		Versione motore Motor version	P_1 [W]	n_2 [min ⁻¹]	M_2 [Nm]	sf	i		Versione motore Motor version		
160							250								
(3000 min ⁻¹)	50	21	1.0	60		120/056/030	120/240	(3000 min ⁻¹)	50	31	0.7	60		180/056/030	180/240
	40	25	0.9	75				40	31	0.7	75				
	33	28	1.0	90				33	39	0.7	90				
	25	35	0.7	120				25	33	0.7	120				
	20	31	0.7	150				20	31	0.7	150				
	50	22	2.0	60		120/056/040	120/240		50	35	1.3	60		180/056/040	180/240
	40	26	1.7	75				40	41	1.1	75				
	33	30	1.9	90				33	46	1.2	90				
	25	36	1.3	120				25	56	0.9	120				
	20	43	1.1	150				20	66	0.7	150				
	17	48	0.9	180				17	61	0.7	180				
	13	55	0.7	240				13	57	0.7	240				
	10	51	0.7	300				10	51	0.7	300				

N.B.
Verificare sempre che la coppia M_2 utilizzata non ecceda il valore indicato nelle caselle in grigio

N.B.
Please check that the output torque M_2 does not exceed the value in the grey areas

NOTA: per servizio continuo o altamente intermittente, contattare il servizio tecnico

NOTE: for continuous or highly intermittent duty, please contact our technical service

Motori applicabili

IEC Motor adapters

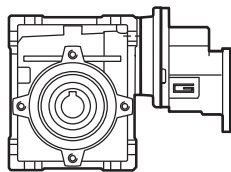
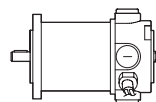

		ND	
		120.120 120.240	180.120 180.240
CMP	056/030	150	300
	056/040	150	300

150

Rapporto di riduzione massimo i_{max}
Maximum ratio i_{max}

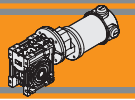

Dimensioni

Dimensions

NDCMP120/056/030 U

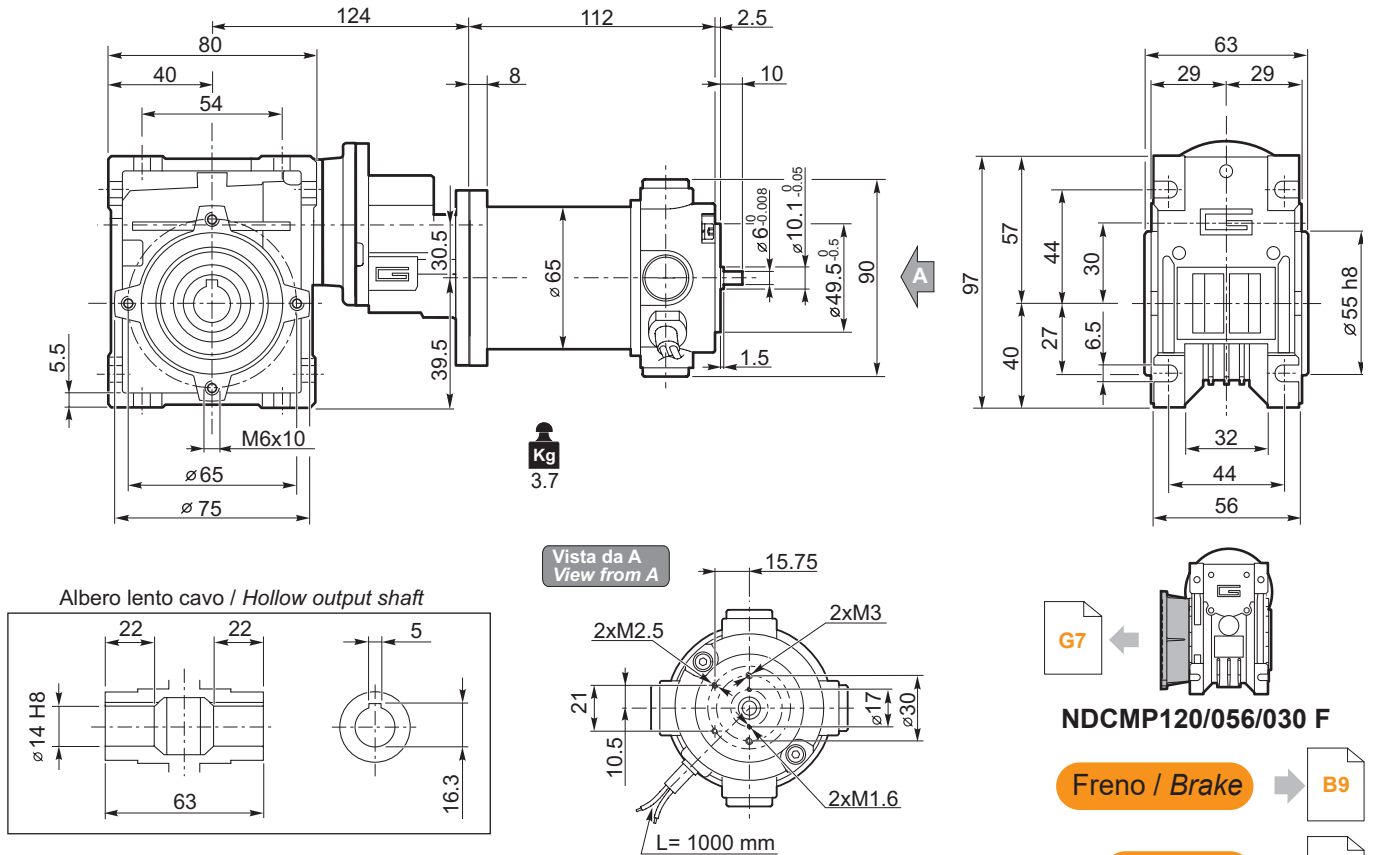

NDCMP120/056/040 U

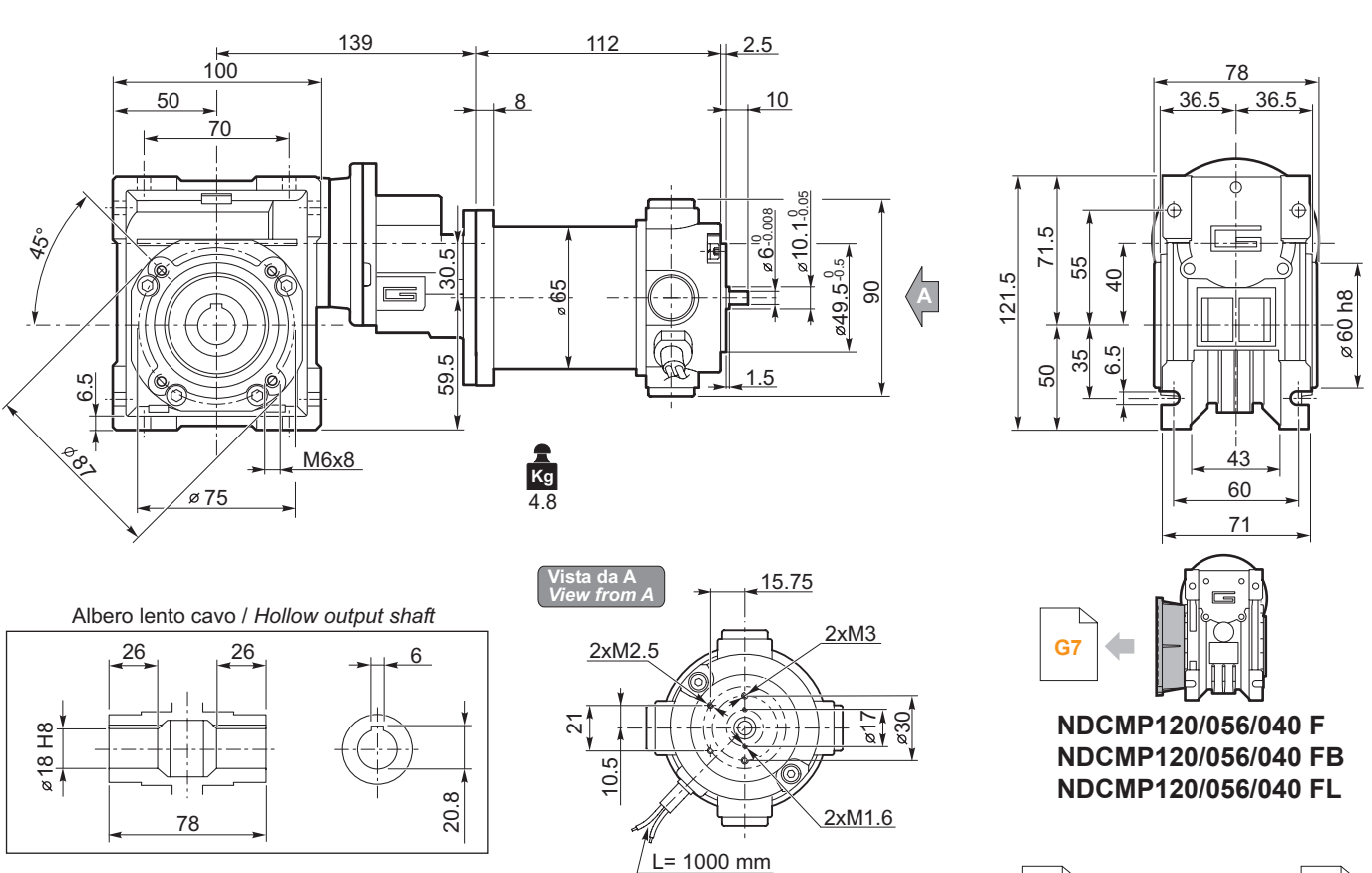

- NDCMP120/056/030 F**
- Freno / Brake** → **B9**
- Encoder** → **B9**

- Freno / Brake** → **B9**
- Encoder** → **B9**

NDCMP

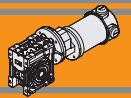

Dimensioni

Dimensions

NDCMP.../... F... Flange uscita / Output flanges

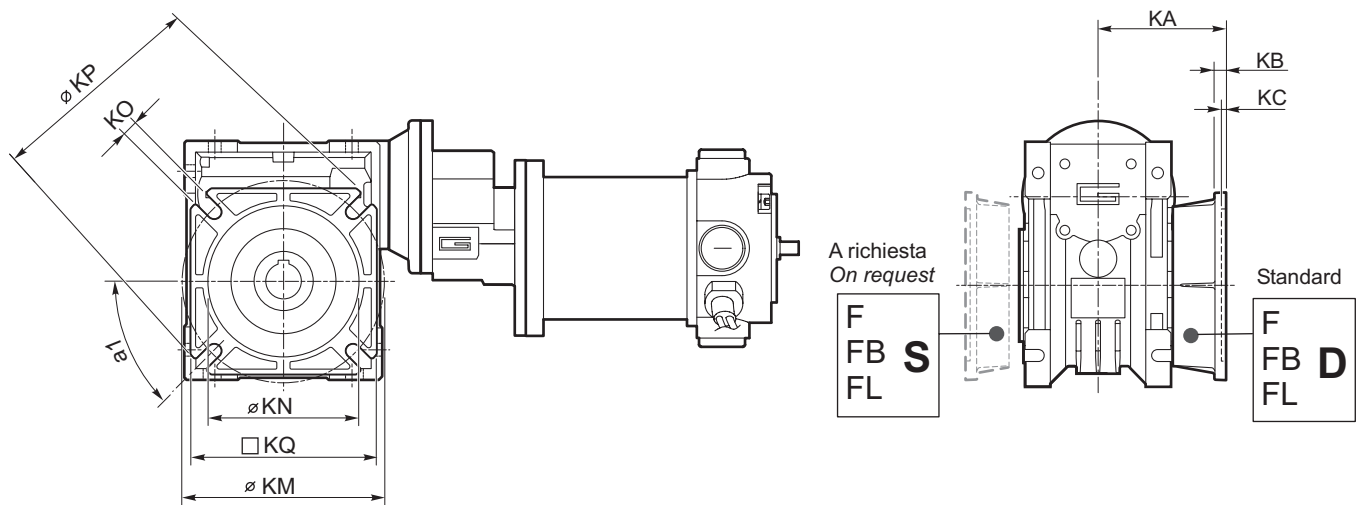

NDCMP

CMP	CMP.F									CMP.FB							CMP.FL								
	a1	KA	KB	KC	KM	KN _{H8}	KO	KP	KQ	KA	KB	KC	KM	KN _{H8}	KO	KP	KQ	KA	KB	KC	KM	KN _{H8}	KO	KP	KQ
056/030	45°	54.5	6	4	68	50	6.5(n.4)	80	70	—	—	—	—	—	—	—	—	—	—	—	—	—	—	—	—
056/040	45°	67	7.5	4.5	80-95	60	9(n.4)	110	95	80	8.5	5	115-125	95	9.5(n.4)	140	112	97	7.5	4.5	80-95	60	10(n.4)	110	95

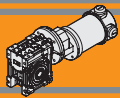

Opzioni

Options

VS - Vite sporgente / Extended input shaft

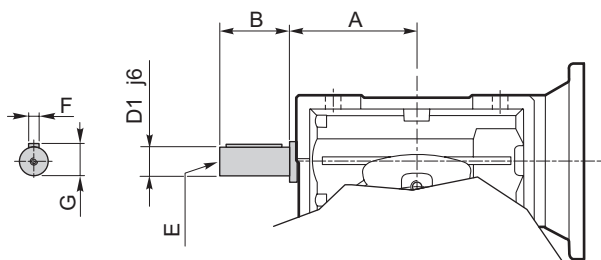

CMP	A	B	D ₁ j6	E	F	G
056/030	45	20	9	M4	3	10.2
056/040	53	23	11	M5	4	12.5

Costruito su richiesta
Built on request

SC - Safety cover

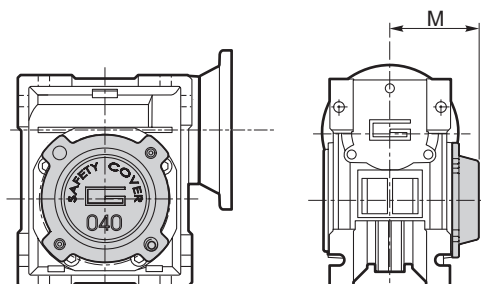

	M
CM 030	47
CM 040	54.5

Accessori

Accessories

Albero lento semplice e doppio

Single and double output shaft

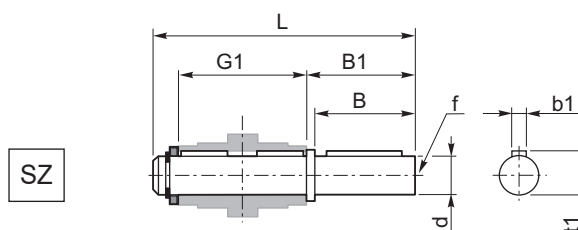
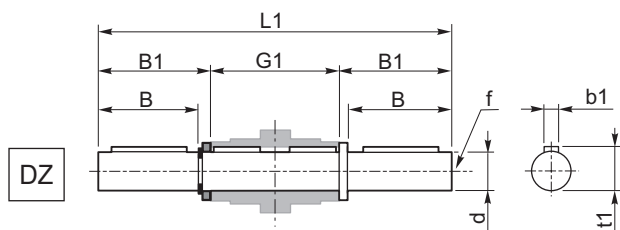

CMP	d h7	B	B1	G1	L	L1	f	b1	t1
056/030	14	30	32.5	63	102	128	M6	5	16
056/040	18	40	43	78	128	164	M6	6	20.5

Braccio di reazione

Torque arm

CMP	K1	G	KG	KH	R
056/030	85	14	23	8	15
056/040	100	14	31	10	18

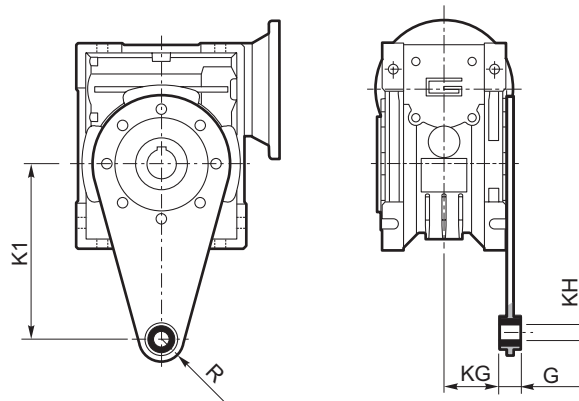

TRANSTECNO[®]
the modular gearmotor

EC

EC



Ferrite

Motori elettrici CC DC electric motors



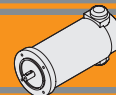

	Indice	Index	Pag. Page
	Caratteristiche tecniche	<i>Technical features</i>	H2
	Simbologia	<i>Symbols</i>	H2
	Grado di protezione IP	<i>IP enclosures protection indexes</i>	H3
	Classe di isolamento termico	<i>Insulation class</i>	H3
	Tipi di servizio IEC	<i>IEC duty cycle ratings</i>	H3
EC020.120	Caratteristiche	<i>Features</i>	H4
EC020.24E	Dimensioni	<i>Dimensions</i>	H4
	Prestazioni	<i>Performances</i>	H5
EC035.120	Caratteristiche	<i>Features</i>	H6
EC035.240	Dimensioni	<i>Dimensions</i>	H6
	Prestazioni	<i>Performances</i>	H7
EC050.12E	Caratteristiche	<i>Features</i>	H8
EC050.24E	Dimensioni	<i>Dimensions</i>	H8
	Prestazioni	<i>Performances</i>	H9
EC070.12E	Caratteristiche	<i>Features</i>	H10
EC070.24E	Dimensioni	<i>Dimensions</i>	H10
	Prestazioni	<i>Performances</i>	H11
EC100.120	Caratteristiche	<i>Features</i>	H12
EC100.240	Dimensioni	<i>Dimensions</i>	H12
EC100.24E	Prestazioni	<i>Performances</i>	H13
EC180.120	Caratteristiche	<i>Features</i>	H14
EC180.240	Dimensioni	<i>Dimensions</i>	H14
EC180.24E	Prestazioni	<i>Performances</i>	H15
EC250.120	Caratteristiche	<i>Features</i>	H16
EC250.240	Dimensioni	<i>Dimensions</i>	H16
	Prestazioni	<i>Performances</i>	H17
EC350.120	Caratteristiche	<i>Features</i>	H18
EC350.240	Dimensioni	<i>Dimensions</i>	H18
	Prestazioni	<i>Performances</i>	H19
EC600.120	Caratteristiche	<i>Features</i>	H20
EC600.240	Dimensioni	<i>Dimensions</i>	H20
	Prestazioni	<i>Performances</i>	H21
	Legenda / Glossario dei grafici	<i>Key / Diagram Glossary</i>	H22
	Formule utili	<i>Useful formulas</i>	H22
	Freni	<i>Brakes</i>	H23
	Encoder	<i>Encoder</i>	H24

Questa sezione annulla e sostituisce ogni precedente edizione o revisione. Qualora questa sezione non Vi sia giunta in distribuzione controllata, l'aggiornamento dei dati ivi contenuto non è assicurato. **In tal caso la versione più aggiornata è disponibile sul nostro sito internet www.transtecno.com**

*This section replaces any previous edition and revision. If you obtained this catalogue other than through controlled distribution channels, the most up to date content is not guaranteed. **In this case the latest version is available on our web site www.transtecno.com***

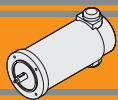

Caratteristiche tecniche

Le caratteristiche principali dei motori elettrici CC a magneti permanenti in ferrite EC sono:

- Campo magnetico generato da magneti permanenti in ferrite
- Costruzione tubolare, senza ventilazione
- Disponibili in 6 grandezze: diametro 42, 52, 65, 81, 104, 110 mm
- Alimentazione a bassa tensione, 12 o 24 Vcc
- Potenze disponibili da 30 a 800 W S2
- Elevate coppie di spunto
- Elevate coppie e potenze in dimensioni compatte

Classe di isolamento termico

Gli avvolgimenti del rotore sono soggetti a surriscaldamento, come pure altre parti del motore. Il grado di isolamento indica la massima temperatura ammissibile oltre la quale l'isolante della matassa e l'isolante di tutte le parti soggette ad elevato riscaldamento perde le caratteristiche di buon isolante, con pericolo di danneggiamento del motore.

Servizio

Rappresenta la relazione tra il tempo di lavoro ed il tempo di riposo del motore. Servizio continuo (S1) = funzionamento continuo del motore a pieno carico.

Servizio intermittente (S2, S3, etc...) = periodi alternati di lavoro e di riposo tali da raffreddare il motore. Dato un motore, la potenza espressa per servizio continuo è inferiore a quella per servizio intermittente.

Fattore di forma

Indica quanta componente spuria alternata è presente nella alimentazione CC del motore. Più alto è il fattore ed inferiore è l'efficienza del motore. Alimentatori ad SCR = F.F 1.40. Alimentazione pura da batteria = FF 1. Alimentazione da transistori (modulazione PWM) = FF 1.05.

Qualitativamente l'andamento della coppia (percentuale) rispetto al fattore di forma è indicato nel grafico seguente:

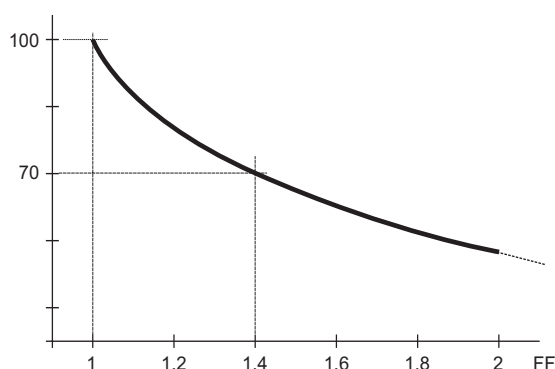

Simbologia

S	—	Servizio / Duty
P_n	[W]	Potenza in uscita / Rated power
P_a	[W]	Potenza assorbita / Absorbed power
M_n	[Nm]	Coppia nominale / Rated torque
V	[V]	Tensione / Voltage
I	[A]	Corrente assorbita / Absorbed current
n₁	[min ⁻¹]	Numero giri motore / Motor speed
S_v	[rad/s]	Velocità angolare / Angular speed
P_e	[W]	Potenza elettrica del freno / Brake electric power

The main features of EC ferrite permanent magnets DC electric motors range are:

- Magnetic field generated by permanent ferrite magnets
- Tubular construction, without fan
- Available in 6 sizes: diameter 42, 52, 65, 81, 104, 110 mm
- Low voltage power supply, 12 or 24 Vdc
- Power ratings available from 30 to 800 W S2
- High starting torque
- High torque and output power with compact package

Thermal insulation class

The windings of the rotor can overheat just like other parts of the motor too. The degree of insulation indicates the maximum allowable temperature above which the insulation of the windings, as well as that of all the parts which heat up to a high temperature, loses its insulating properties and the motor therefore risks being damaged.

Duty cycle

This represents the relationship between the time the motor operates and the time it remains stationary. Continuous operation (S1) = the motor operates non-stop under full load.

Intermittent operation (S2, S3, etc.) = alternating periods of work and rest so that the motor can cool down. The output power for continuous operation is lower than that for intermittent operation.

Form factor

It indicates how much spurious alternating current is present in the D.C. motor power supply. The higher the factor, the lower the motor's efficiency. SCR power supplies = F.F 1.40. Battery supply = FF 1 Transistor supply (PWM modulation) = FF 1.05.

The graph below indicates the torque trend (percentage) in relation to the form factor.

Symbols

M_{Br}	[Nm]	Coppia nominale del freno / Brake motor torque
n_{1 max}	[min ⁻¹]	Velocità massima / Max speed
T_r	[ms]	Tempo di inserzione / Engaging time
T_f	[ms]	Tempo di disimpegno / Disengaging time
IC	—	Classe d'isolamento termico / Thermal insulation class
FF	—	Fattore di forma / Form factor
IP	—	Classe di protezione / Protection class
η	—	Rendimento / Efficiency
Kg	—	Peso / Weight

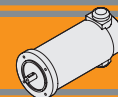

Grado di protezione IP

IP enclosures protection indexes

Indica il grado di isolamento meccanico del corpo motore.

1^a cifra protezione alla penetrazione di corpi solidi.

2^a cifra protezione contro la penetrazione d'acqua.

Indicates the degree of mechanical insulation of the motor body.

1st figure indicating level of protection against the penetration of solid bodies.

2nd figure: indicating degree to which the motor is waterproof.

0	Non protetto / No protection	0	Non protetto / No protection
1	Protetto da corpi solidi superiori a Ø 50 mm. Protected against solid matters (over Ø 50 mm)	1	Protetto contro la caduta verticale di gocce d'acqua. Protected against drops of water falling vertically
2	Protetto da corpi solidi superiori a Ø 12 mm. Protected against solid matters (over Ø 12 mm)	2	Protetto contro la caduta verticale di gocce d'acqua con inclinazione max di 15° Protected against drops of water falling up to 15°
3	Protetto da corpi solidi superiori a Ø 2,5 mm. Protected against solid matters (over Ø 2,5 mm)	3	Protetto contro la pioggia. Rain proof fixture
4	Protetto da corpi solidi superiori a Ø1 mm. Protected against solid matters (over Ø1 mm)	4	Protetto contro gli spruzzi. Splash proof fixture
5	Protetto contro la polvere Dust proof	5	Protetto contro getti d'acqua Water jet proof
6	Totalmente protetto contro la polvere Fully dust proof	6	Protetto dalle ondate Wave proof
7	N.A.	7	Protetto contro immersione Watertight immersion fixture.
8	N.A.	8	Protetto contro immersione/sommersione prolungata Watertight immersion fixture for a long time.

Classe di isolamento termico

Insulation class

Classe / Class	Δ t °C Temp. ambiente: 40°C Ambient temperature: 40°C
A	65°C
B	90°C
F	115°C
H	140°C

Tipi di servizio IEC

IEC duty cycle ratings

S1	Servizio continuo. Funzionamento a carico costante per una durata sufficiente al raggiungimento dell' equilibrio termico.	Continuous duty. The motor works at a constant load for enough time to reach temperature equilibrium
S2	Servizio di durata limitata. Funzionamento a carico costante per una durata inferiore a quella necessaria al raggiungimento dell' equilibrio termico, seguito da un periodo di riposo tale da riportare il motore alla temperatura ambiente.	Short time duty. The motor works at a constant load, but not long enough to reach temperature equilibrium, and the rest periods are long enough for the motor to reach ambient temperature.
S3	Servizio periodico intermittente. Sequenze di cicli identici di marcia e di riposo a carico costante, senza raggiungimento dell' equilibrio termico. La corrente di spunto ha effetti trascurabili sul surriscaldamento del motore.	Intermittent periodic duty. Sequential, identical run and rest cycles with constant load. Temperature equilibrium is never reached. Starting current has little effect on temperature rise.
S4	Servizio periodico intermittente con avviamento. Sequenza di cicli di funzionamento identici di avviamento, marcia e riposo a carico costante, senza raggiungimento dell'equilibrio termico. La corrente di spunto ha effetti sul riscaldamento del motore.	Intermittent periodic duty with starting. Sequential identical start, run and rest cycles with constant load. Temperature equilibrium is not reached, but starting current affects temperature rise.
S5	Servizio periodico intermittente con frenatura elettrica. Sequenza di cicli di funzionamento identici di avviamento, marcia a carico costante, frenatura elettrica e riposo, senza raggiungimento dell'equilibrio termico.	Intermittent periodic duty with electric braking. Sequential, identical cycles of starting, running at constant load, electric braking and rest. Temperature equilibrium is not reached.
S6	Servizio periodico ininterrotto con carico intermittente. Sequenza di cicli di lavoro identici con carico costante e senza carico. Non ci sono periodi di riposo.	Continuous operation with intermittent load. Sequential, identical cycles of running with constant load and running with no load. No rest periods.
S7	Servizio periodico ininterrotto con frenatura elettrica. Sequenza di cicli di funzionamento identici di avviamento, marcia a carico costante e frenatura elettrica, senza periodi di riposo.	Continuous operation with electric braking. Sequential, identical cycles of starting, running at constant load and electric braking. No rest periods.
S8	Servizio periodico ininterrotto con variazioni di carico e di velocità. Sequenza di cicli identici di avviamento, marcia a carico costante e velocità definita, seguiti da marcia a carico costante differente e velocità differente dalla precedente. Non ci sono periodi di riposo.	Continuous operation with periodic changes in load and speed. Sequential, identical, duty cycles of start, run at constant load and given speed, then run at other constant loads and speeds. No rest periods.

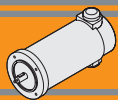

EC020.120 - EC020.24E

Caratteristiche

Features

Costruzione	Tubolare, senza ventilazione
Grandezza	Ø 42 mm
Potenza	30 W S2 (20 W S1)
Magneti	2
Supporti	Cuscinetti a sfera
Fori di montaggio	4
Alimentazione	Bassa tensione, 12 o 24 Vcc
Spazzole	N° 2 di composto grafite-rame
Cavo di alimentazione	Connettori faston (0.8 x 2.8 mm)
Opzioni	Filtro EMC

Construction	Tubular, without fan
Size	Ø 42 mm
Power	30 W S2 (20 W S1)
Magnets	2
Bearings	Ball bearing
Mounting holes	4
Power supply	Low voltage, 12 or 24 Vdc
Brushes	2 brushes made of graphite/copper composite
Electric cable	Faston terminals (0.8 x 2.8 mm)
Options	EMC filter

Tipo Type	S	Pn [W]	V [V]	I [A]	IC	FF	Mn [Nm]	n ₁ [min ⁻¹]	IP	Kg
EC020.120	S1	20	12	2.6	B	1	0.06	2850	20	0.4
	S2 6'	30		3.5			0.08			
EC020.24E	S1	20	24	1.4			0.06			
	S2 6'	30		1.9			0.08			

Dimensioni

Dimensions

EC020.120

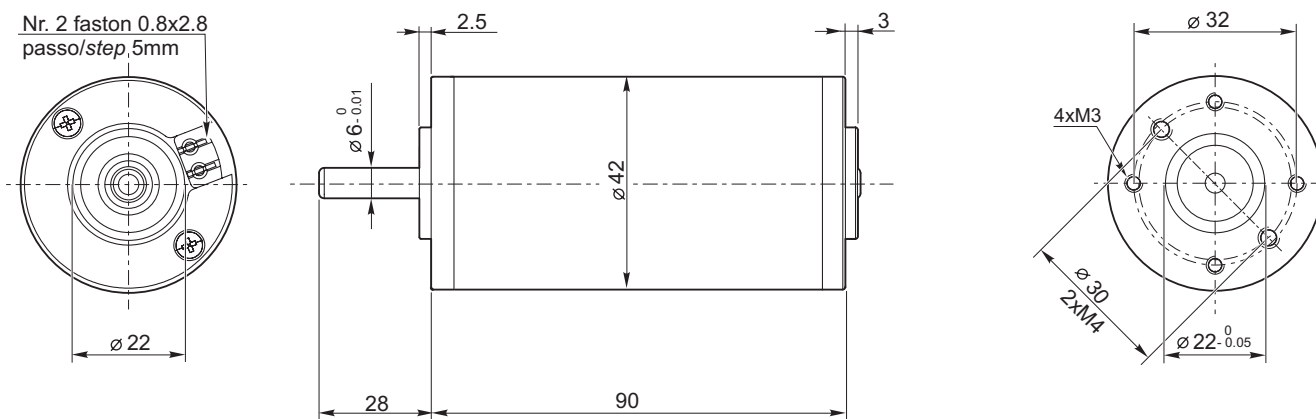

EC020.24E

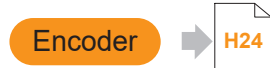
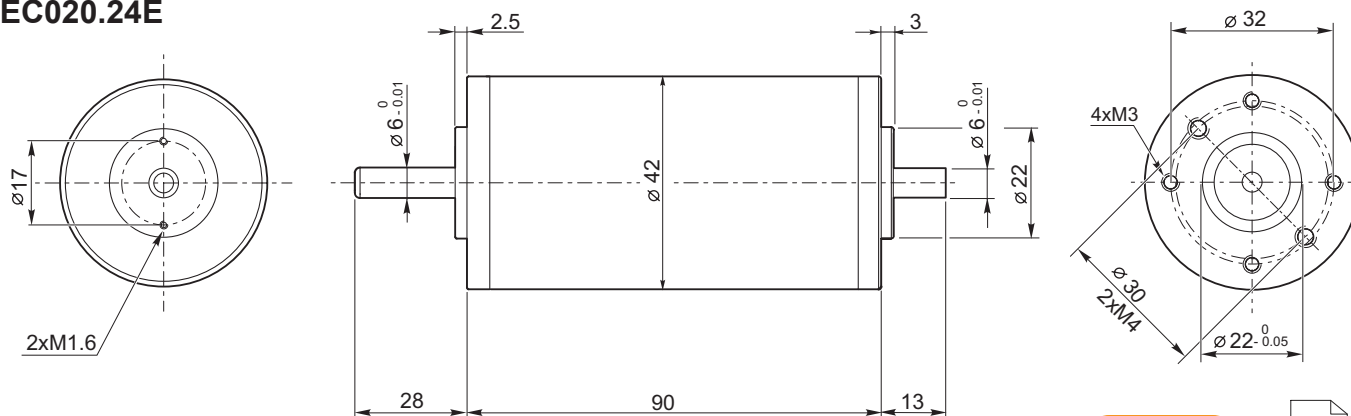

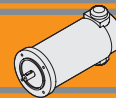

EC020.120 - EC020.24E

Prestazioni

Performances

EC020.120

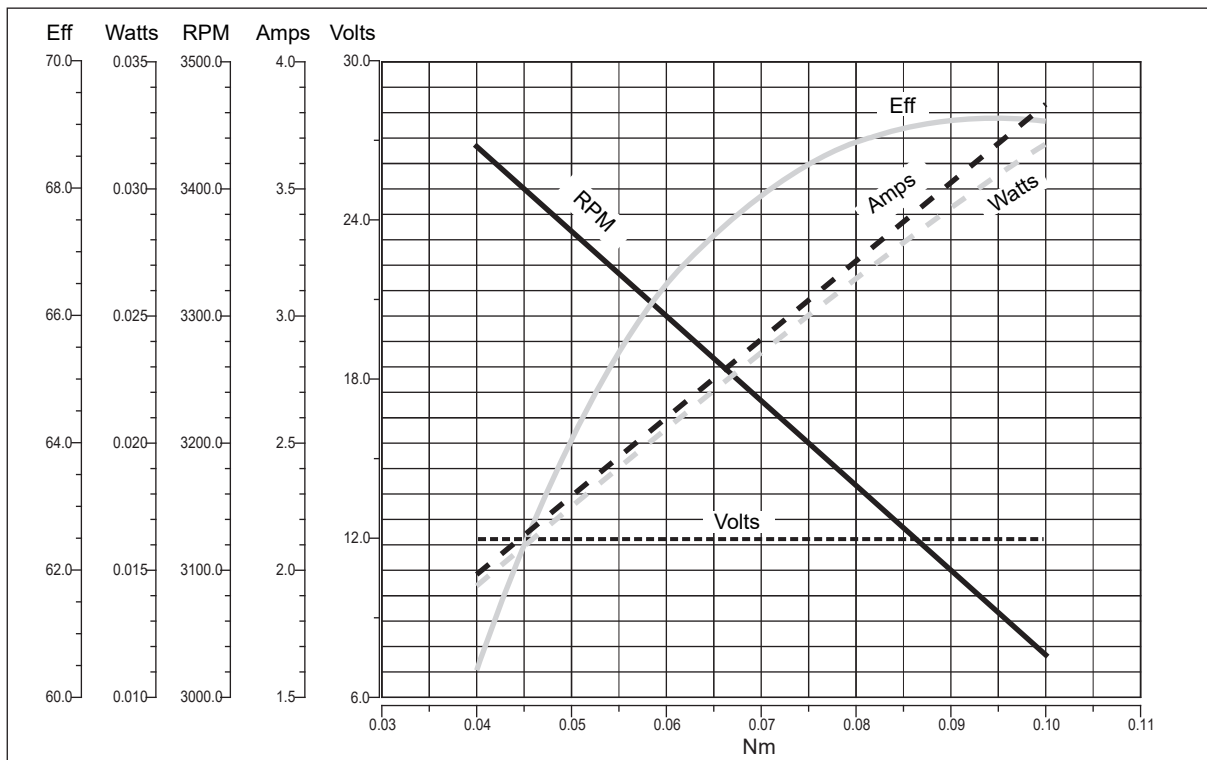

EC020.24E

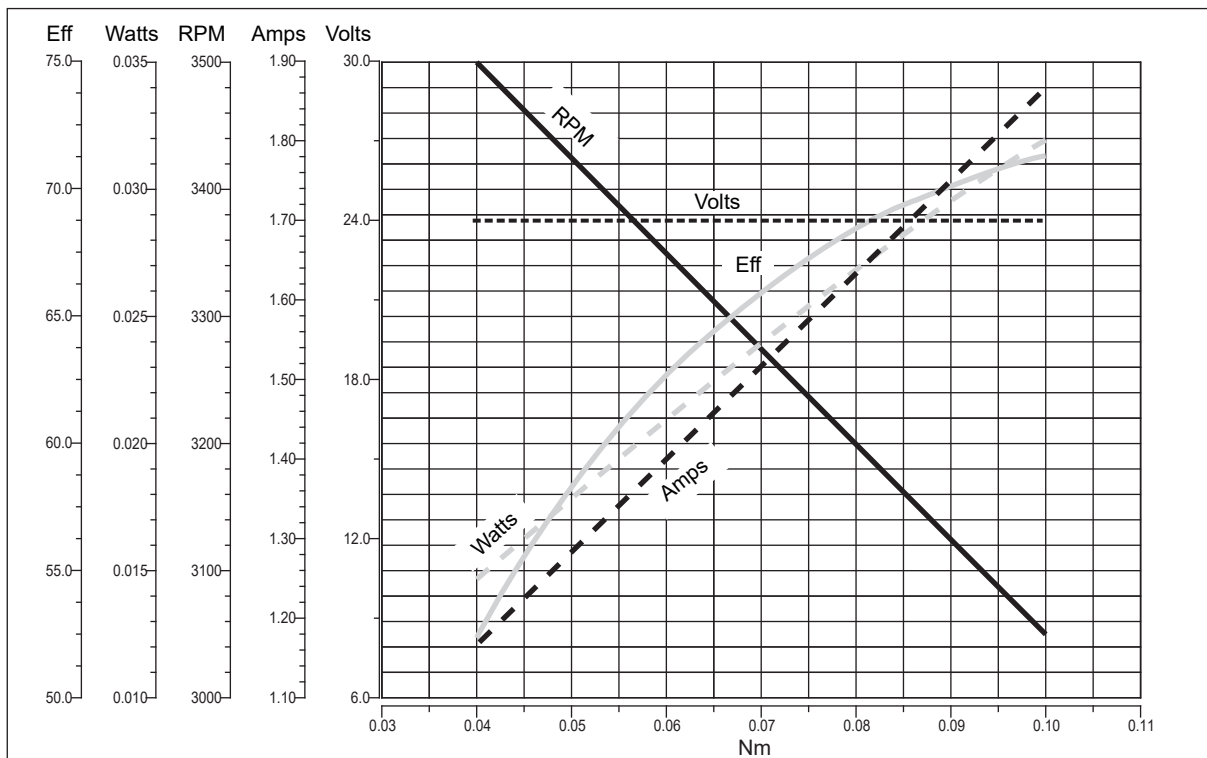

EC

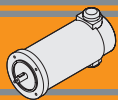

EC035.120 - EC035.240

Caratteristiche

Features

Costruzione	Tubolare, senza ventilazione
Grandezza	Ø 52 mm
Potenza	55 W S2 (35 W S1)
Magneti	2
Supporti	Cuscinetti a sfera
Fori di montaggio	4
Alimentazione	Bassa tensione, 12 o 24 Vcc
Spazzole	N° 2 interne di composto grafite-rame
Cavo di alimentazione	Lunghezza: 200 mm

Construction	Tubular, without fan
Size	Ø 52 mm
Power	55 W S2 (35 W S1)
Magnets	2
Bearings	Ball bearings
Mounting holes	4
Power supply	Low voltage, 12 or 24 Vdc
Brushes	2 inside brushes made of graphite/copper composite
Electric cable	Length: 200 mm

Tipo Type	S	Pn [W]	V [V]	I [A]	IC	FF	Mn [Nm]	n ₁ [min ⁻¹]	IP	Kg
EC035.120	S1	35	12	5.2	F	1	0.11	3000	20	0.8
	S2 9'	55		8.0			0.18			
EC035.240	S1	35	24	2.6	F	1	0.11		20	0.8
	S2 9'	55		4.0			0.18			

Dimensioni

Dimensions

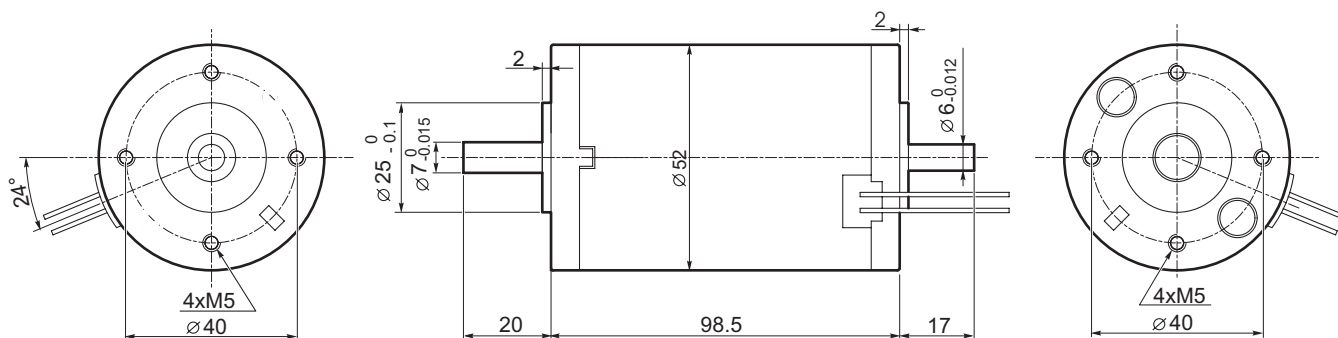

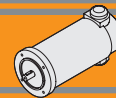

EC035.120 - EC035.240

Prestazioni

Performances

EC035.120

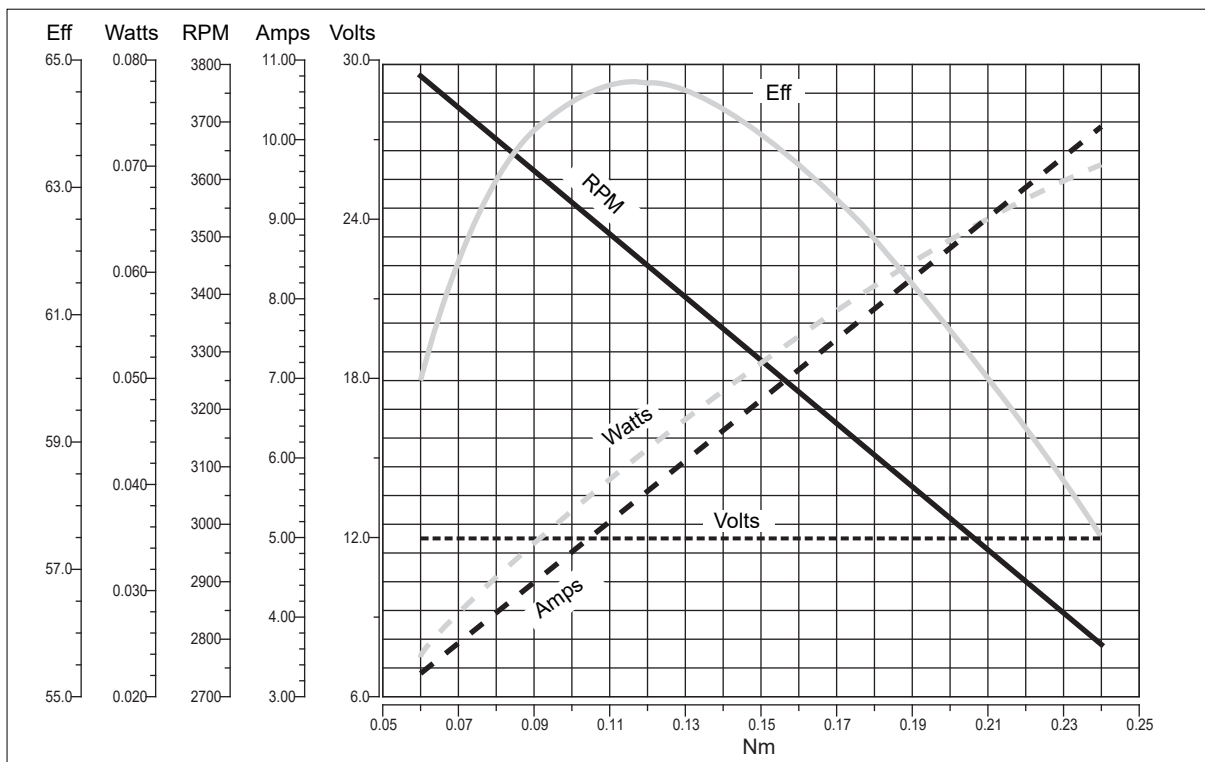

EC035.240

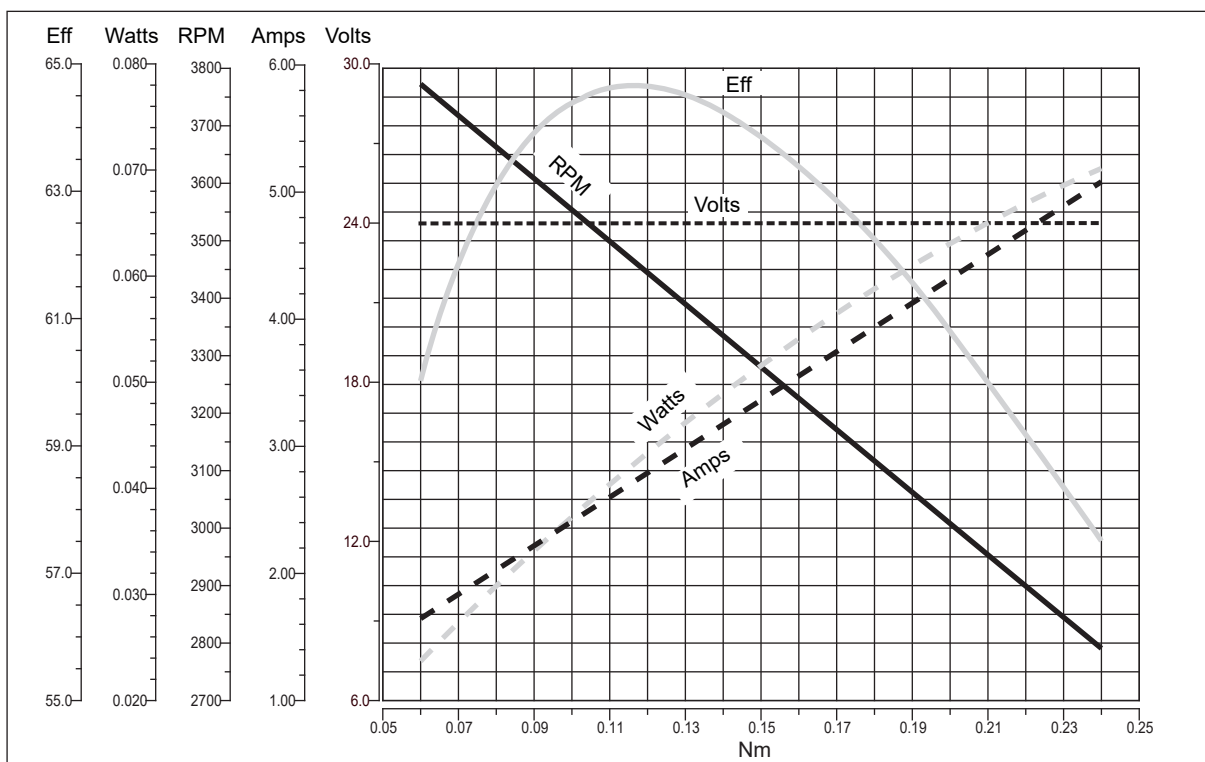

EC

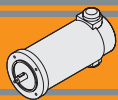

EC050.12E - EC050.24E

Caratteristiche

Features

Costruzione	Tubolare, senza ventilazione
Grandezza	Ø 65 mm
Potenza	70 W S2 (50 W S1)
Magneti	2
Supporti	Cuscinetti a sfera
Fori di montaggio	4
Alimentazione	Bassa tensione, 12 o 24 Vcc
Spazzole	N° 2 interne di composto grafite-rame
Cavo di alimentazione	Lunghezza: 200 mm
Bisporgenza	Standard

Construction	Tubular, without fan
Size	Ø 65 mm
Power	70 W S2 (50 W S1)
Magnets	2
Bearings	Ball bearings
Mounting holes	4
Power supply	Low voltage, 12 or 24 Vdc
Brushes	2 inside brushes made of graphite/copper composite
Electric cable	Length: 200 mm
Rear Shaft	Standard

Tipo Type	S	Pn [W]	V [V]	I [A]	IC	FF	Mn [Nm]	n ₁ [min ⁻¹]	IP	Kg
EC050.12E	S1	50	12	6.5	F	1	0.16	3000	20	1.2
	S2 30'	70		9.0			0.22			
EC050.24E	S1	50	24	3.2			0.16			
	S2 30'	70		4.5			0.22			

Dimensioni

Dimensions

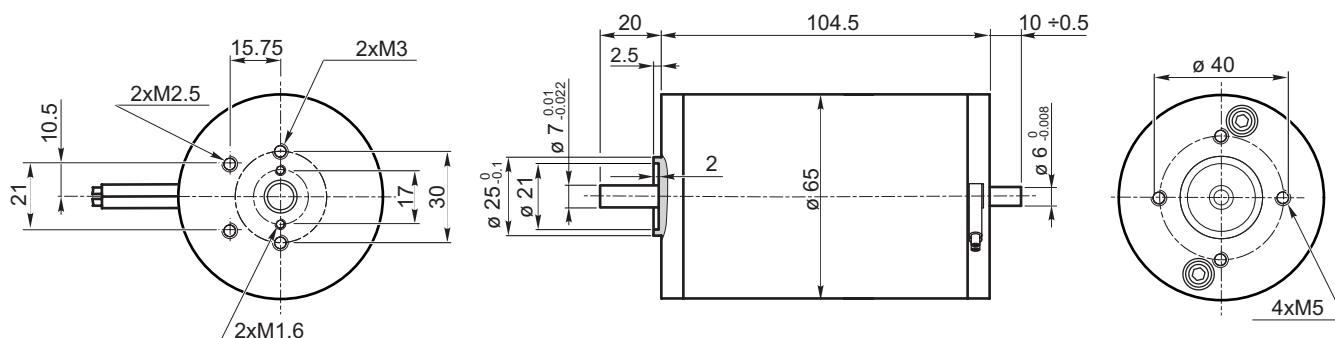

Freno / Brake → [H23](#)

Encoder → [H24](#)

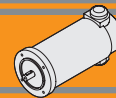

EC050.12E - EC050.24E

Prestazioni

Performances

EC050.12E

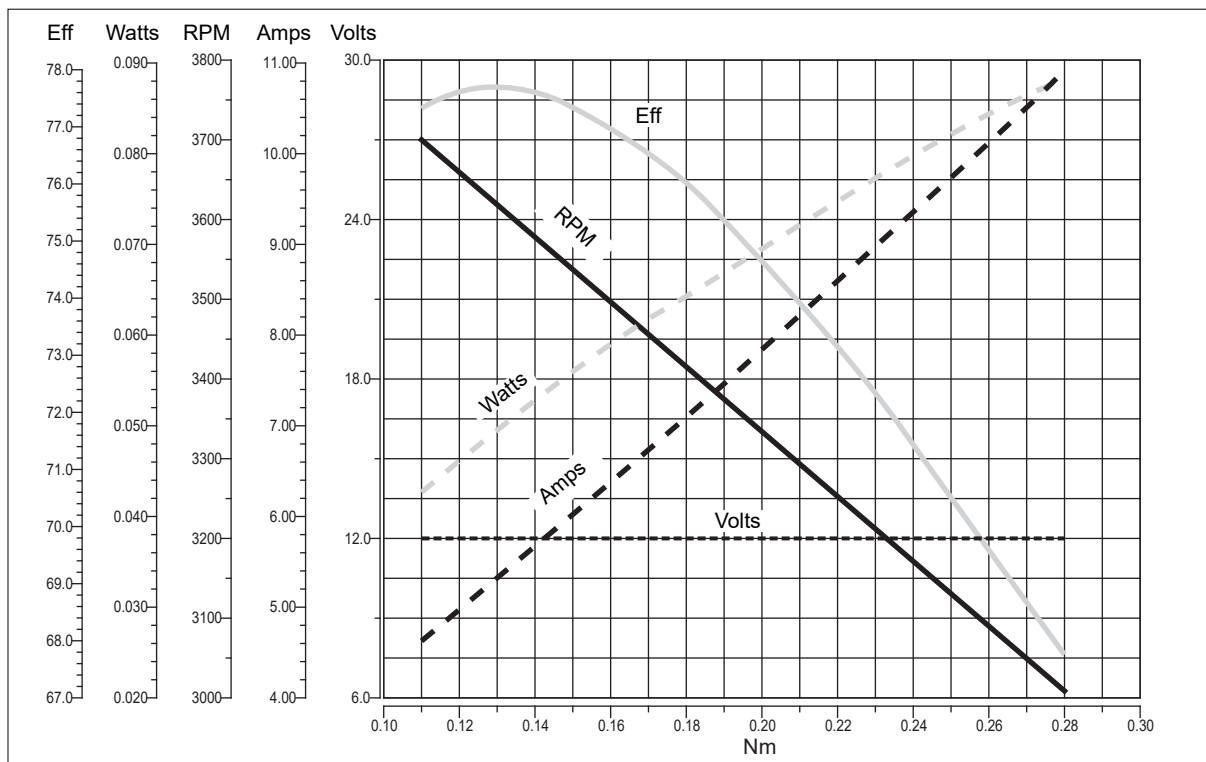

EC050.24E

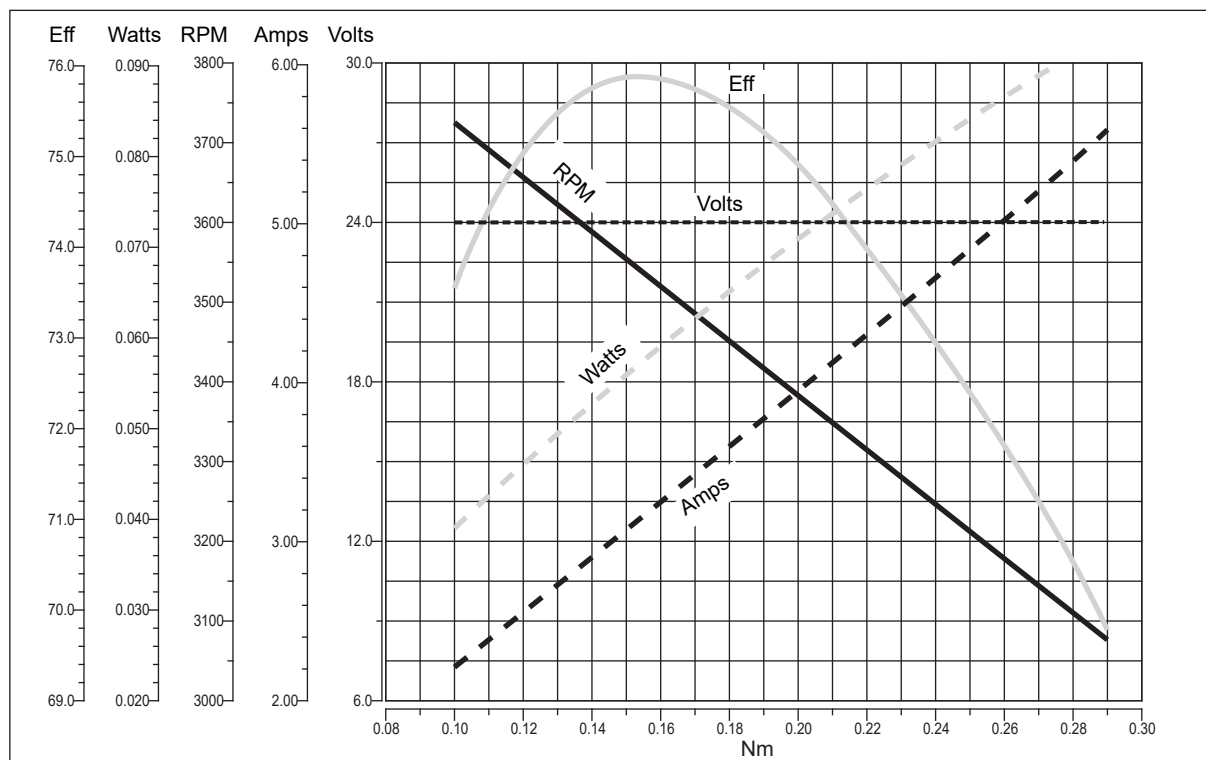

EC

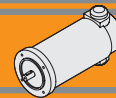

EC070.12E - EC070.24E

Prestazioni

Performances

EC070.12E

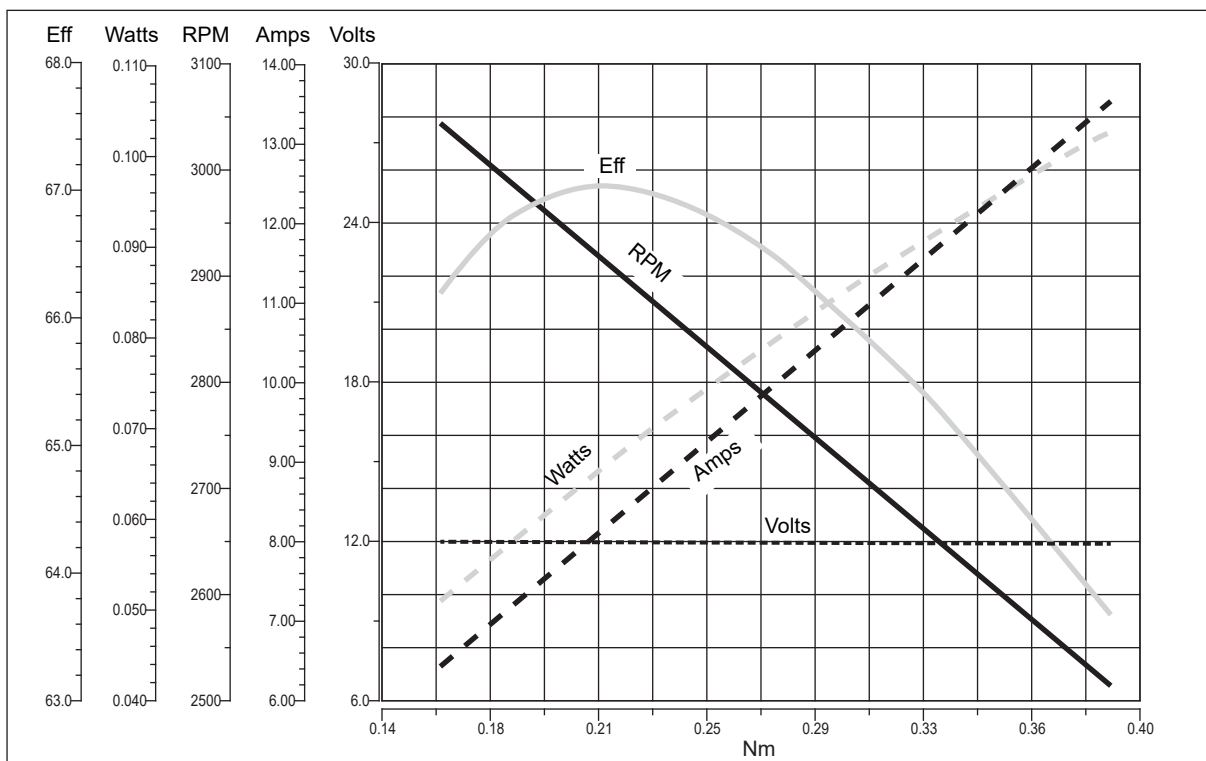

EC070.24E

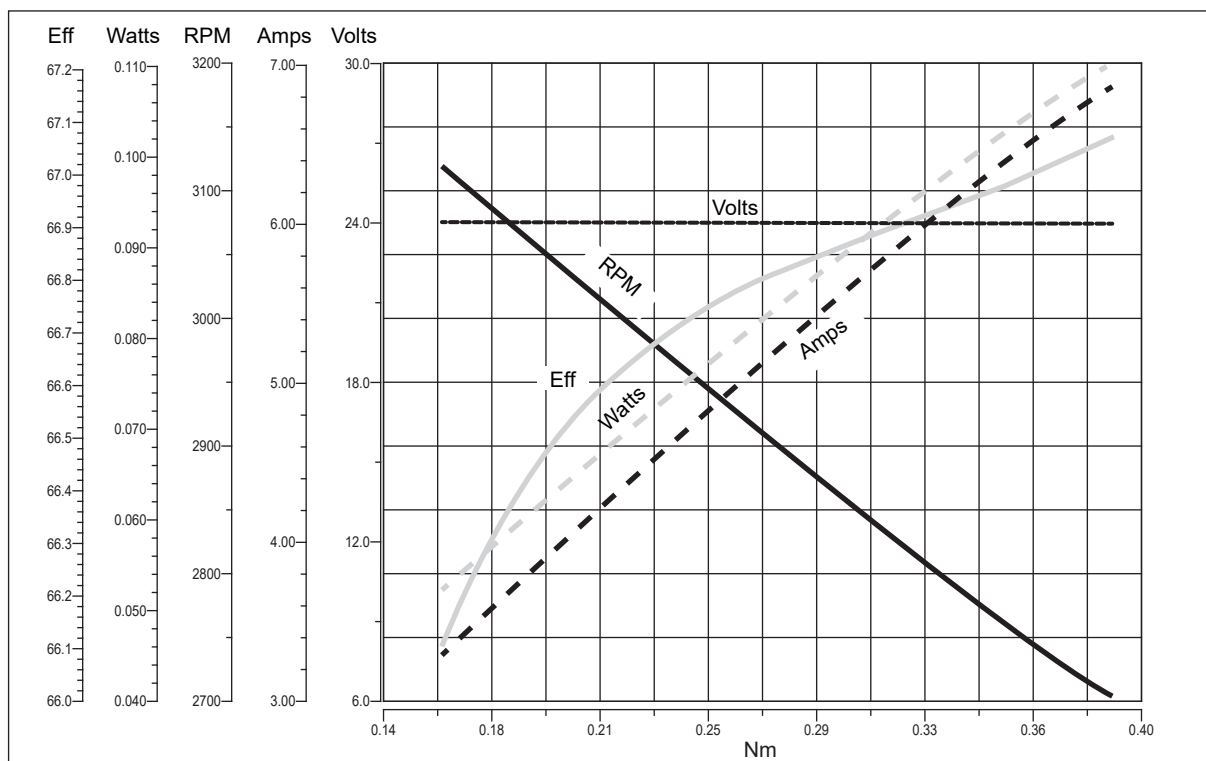

EC

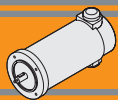

EC100.120 - EC100.240 - EC100.24E

Caratteristiche

Features

Costruzione	Tubolare, senza ventilazione
Grandezza	Ø 80 mm
Potenza	140 W S2 (100 W S1)
Magneti	2
Supporti	Cuscinetti a sfera
Fori di montaggio	4
Alimentazione	Bassa tensione, 12 o 24 Vcc
Spazzole	N° 2 di composto grafite-rame
Dimensione spazzole	LxPxH = 17.1 x 6.5 x 16.7 mm
Cavo di alimentazione	Lunghezza: 1000 mm
Bisporgenza	Standard solo EC100.24E

Construction	Tubular, without fan
Size	Ø 80 mm
Power	140 W S2 (100 W S1)
Magnets	2
Bearings	Ball bearings
Mounting holes	4
Power supply	Low voltage, 12 or 24 Vdc
Brushes	2 inside brushes made of graphite/copper composite
Brushes size	LxWxH = 17.1 x 6.5 x 16.7 mm
Electric cable	Length: 1000 mm
Rear shaft	Standard only EC100.24E

Tipo Type	S	Pn [W]	V [V]	I [A]	IC	FF	Mn [Nm]	n ₁ [min ⁻¹]	IP	Kg
EC100.120	S1	100	12	12	F	1	0.31	3000	40	2.7
	S2 25'	140		16.8			0.43			
EC100.240	S1	100	24	6			0.31			
	S2 25'	140		8.4			0.43			
EC100.24E	S1	100	24	6			0.31		20	
	S2 25'	140		8.4			0.43			

Dimensioni

Dimensions

**EC100.120
EC100.240**

56 B14	
L	153
D	80
S	65
C (-0.03 / -0.01)	50
63B14*	
L	155
D	90
S	75
C (-0.03 / -0.01)	60

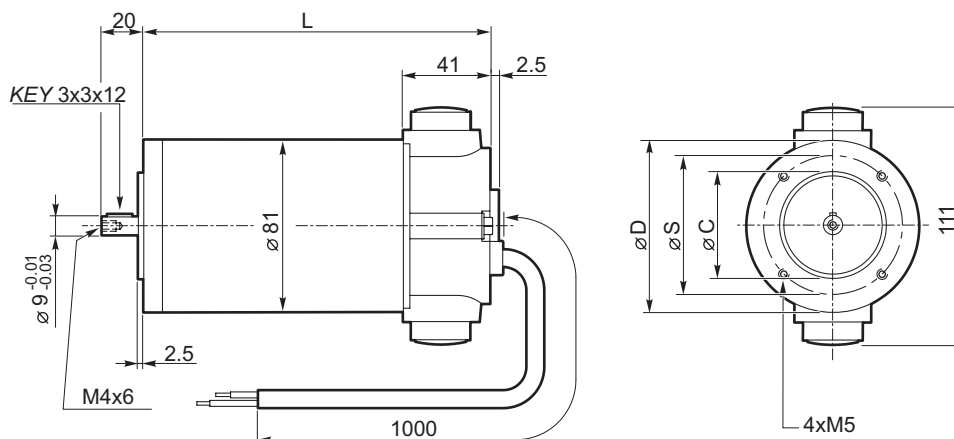

* Usare boccola 9/11
* Use sleeve 9/11

Freno / Brake → [H23](#)

Encoder → [H24](#)

EC100.24E

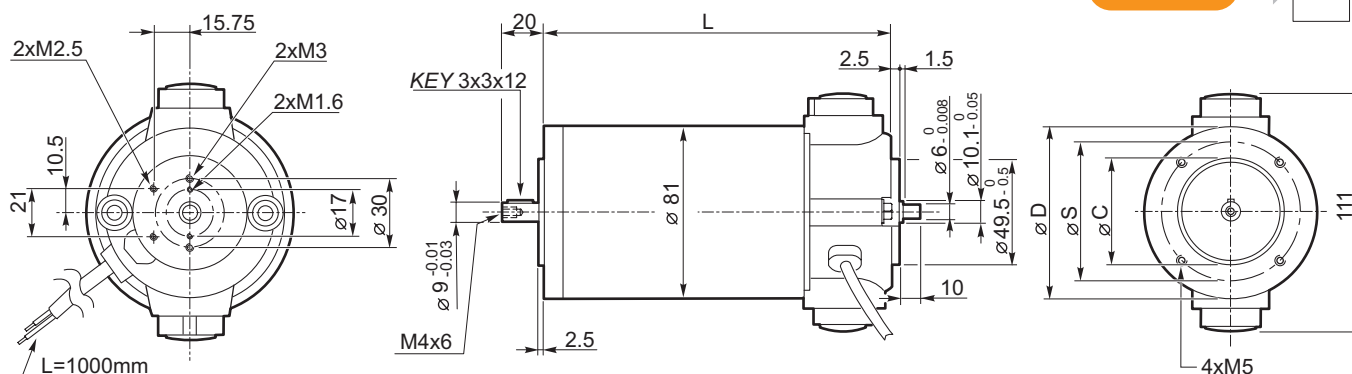

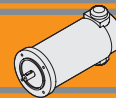

EC100.120 - EC100.240 - EC100.24E

Prestazioni

Performances

EC100.120

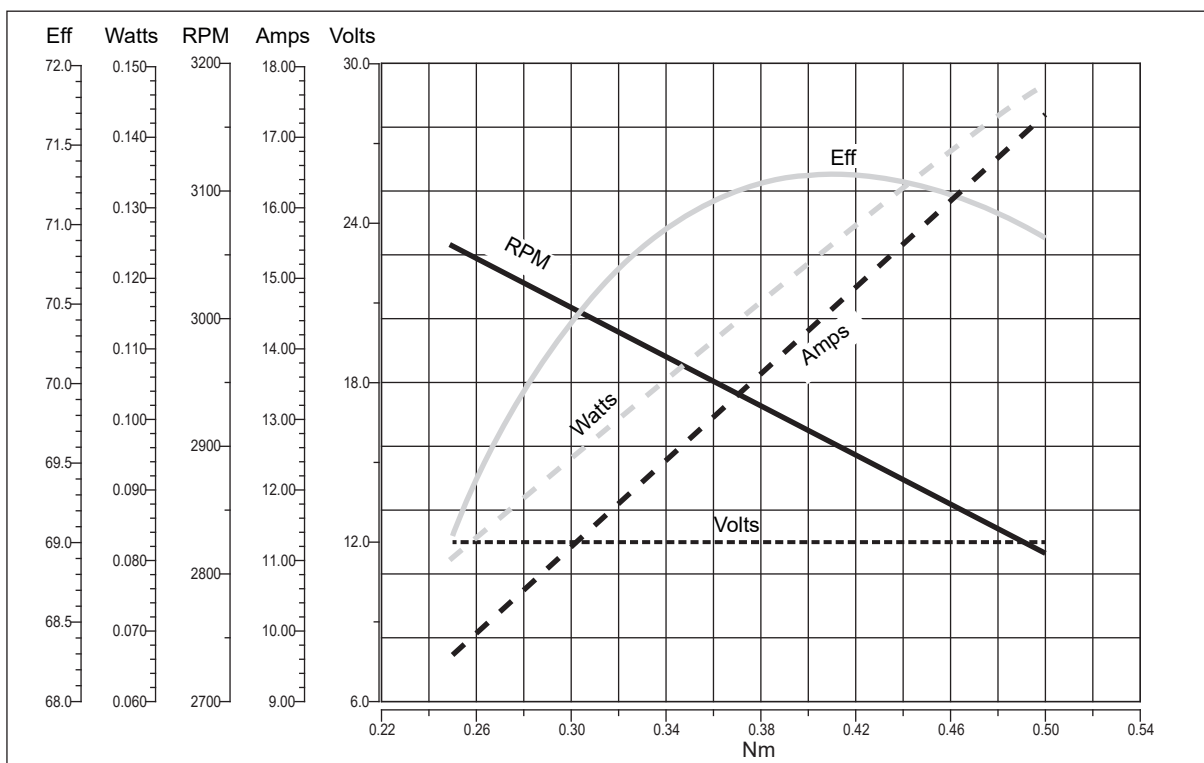

EC100.240 - EC100.24E

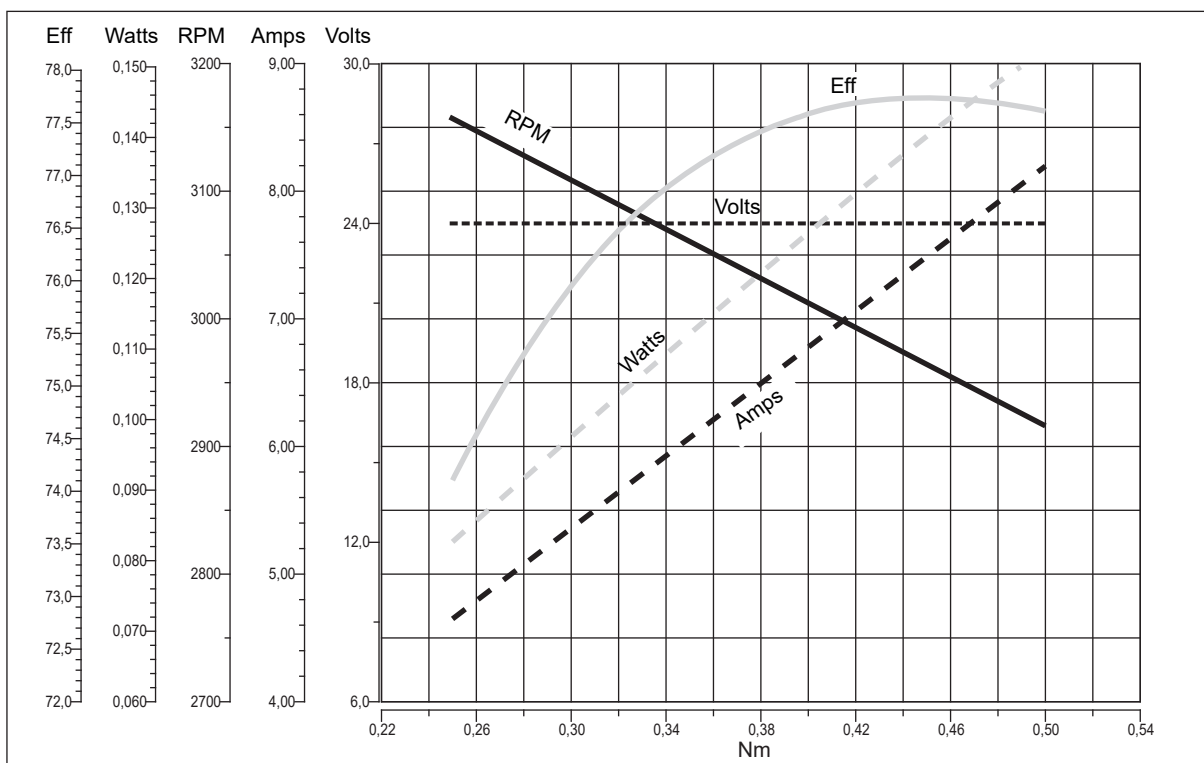

EC

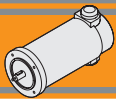

EC180.120 - EC180.240 - EC180.24E

Caratteristiche

Features

Costruzione	Tubolare, senza ventilazione
Grandezza	Ø 80 mm
Potenza	250 W S2 (180 W S1)
Magneti	2
Supporti	Cuscinetti a sfera
Fori di montaggio	4
Alimentazione	Bassa tensione, 12 o 24 Vcc
Spazzole	N° 2 di composto grafite-rame
Dimensione spazzole	LxPxH = 17.1 x 6.5 x 16.7 mm
Cavo di alimentazione	Lunghezza: 1000 mm
Bisporgenza	Standard solo EC180.24E

Construction	Tubular, without fan
Size	Ø 80 mm
Power	250 W S2 (180 W S1)
Magnets	2
Bearings	Ball bearings
Mounting holes	4
Power supply	Low voltage, 12 or 24 Vdc
Brushes	2 inside brushes made of graphite/copper composite
Brushes size	LxPxH = 17.1 x 6.5 x 16.7 mm
Electric cable	Length: 1000 mm
Rear shaft	Standard only EC180.24E

Tipo Type	S	Pn [W]	V [V]	I [A]	IC	FF	Mn [Nm]	n ₁ [min ⁻¹]	IP	Kg
EC180.120	S1	180	12	21.5	F	1	0.57	3000	40	3.4
	S2 25'	250		30			0.8			
EC180.240	S1	180	24	10.8			0.57			
	S2 25'	250		15			0.8			
EC180.24E	S1	180		10.8			0.57		20	
	S2 25'	250		15			0.8			

Dimensioni

Dimensions

**EC180.120
EC180.240**

56 B14	
L	185
D	80
S	65
C (-0.03 / -0.01)	50
63B14*	
L	187
D	90
S	75
C (-0.03 / -0.01)	60

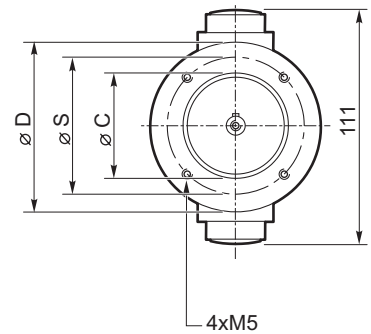
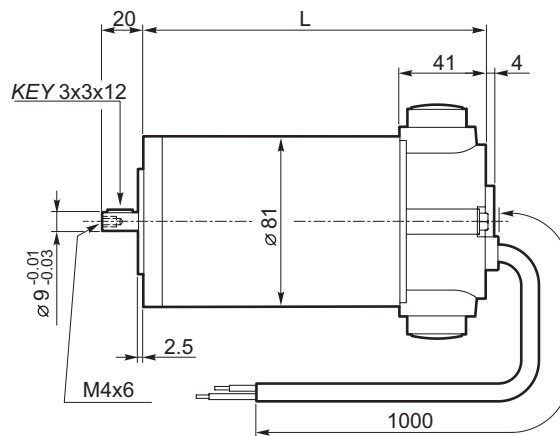

* Usare boccola 9/11
* Use sleeve 9/11

Freno / Brake → H23

Encoder → H24

EC180.24E

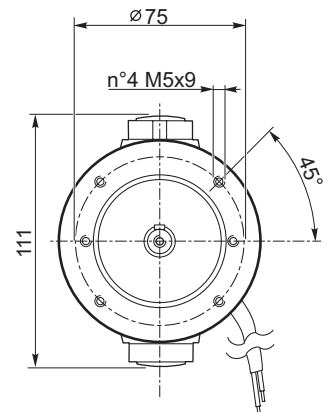
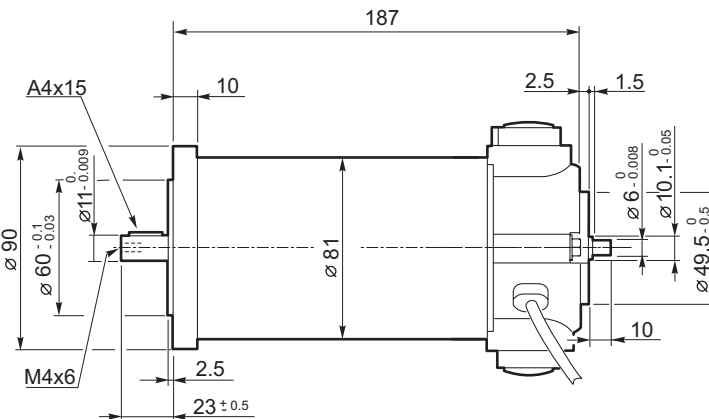
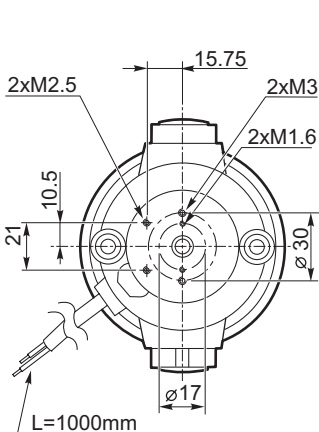

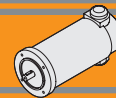

EC180.120 - EC180.240 - EC180.24E

Prestazioni

Performances

EC180.120

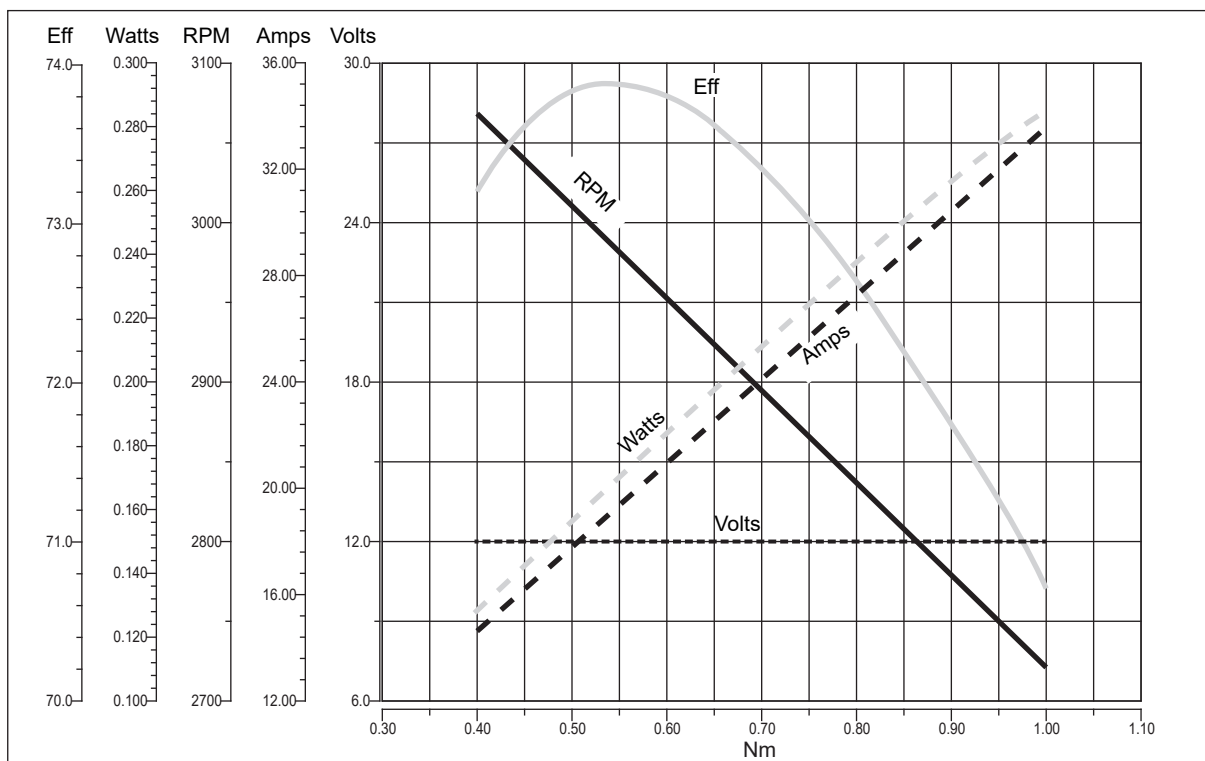

EC180.240 - EC180.24E

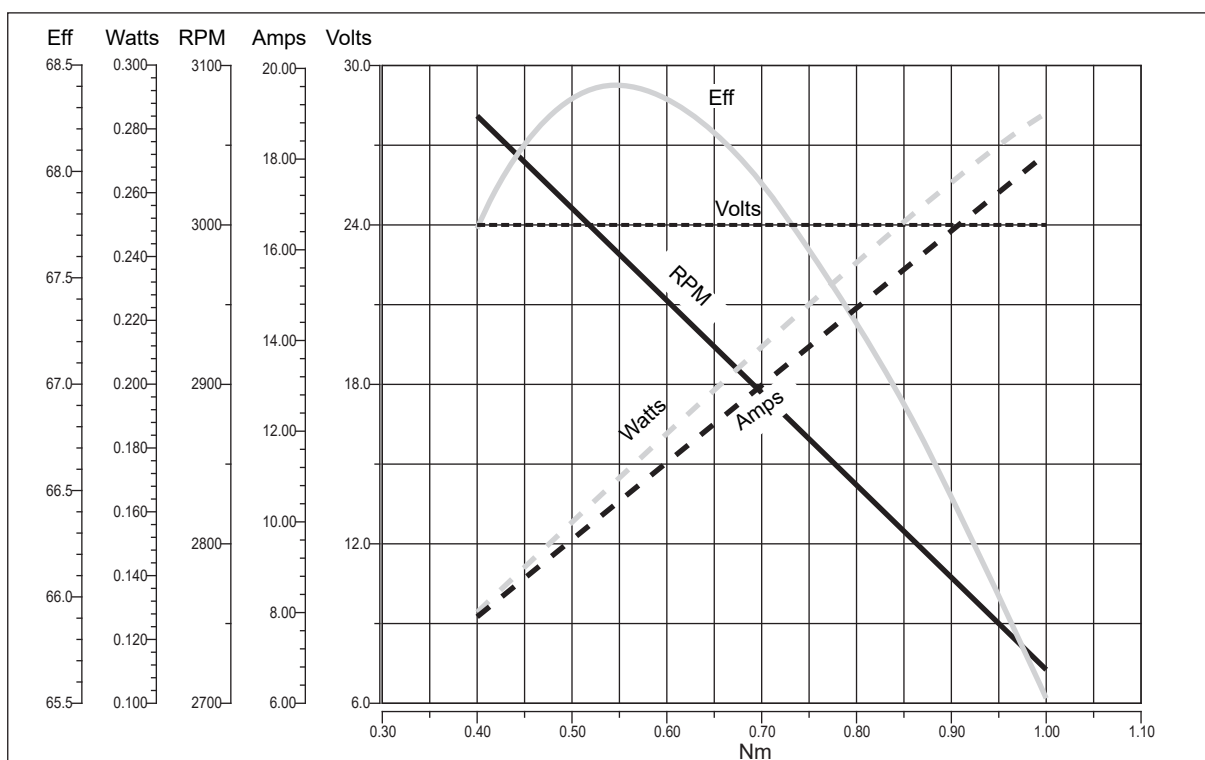

EC

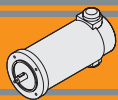

EC250.120 - EC250.240

Caratteristiche

Features

Costruzione	Tubolare, senza ventilazione
Grandezza	Ø 104 mm
Potenza	350 W S2 (250 W S1)
Magneti	4
Supporti	Cuscinetti a sfera
Fori di montaggio	8
Alimentazione	Bassa tensione, 12 o 24 Vcc
Spazzole	N° 4 di composto grafite-rame
Dimensione spazzole	LxPxH = 18.9 x 9.5 x 16.7 mm
Terminali	2 con doppio dado di fissaggio

Construction	Tubular, without fan
Size	Ø 104 mm
Power	350 W S2 (250 W S1)
Magnets	4
Bearings	Ball bearings
Mounting holes	8
Power supply	Low voltage, 12 or 24 Vdc
Brushes	4 inside brushes made of graphite/copper composite
Brushes size	LxPxH = 18.9 x 9.5 x 16.7 mm
Leads terminals	2, with double nut

Tipo Type	S	Pn [W]	V [V]	I [A]	IC	FF	Mn [Nm]	n ₁ [min ⁻¹]	IP	Kg
EC250.120	S1	250	12	30	F	1	0.8	3000	40	4.15
	S2 25'	350		38.5			1.12			
EC250.240	S1	250	24	15			0.8			
	S2 25'	350		20.5			1.12			

Dimensioni

Dimensions

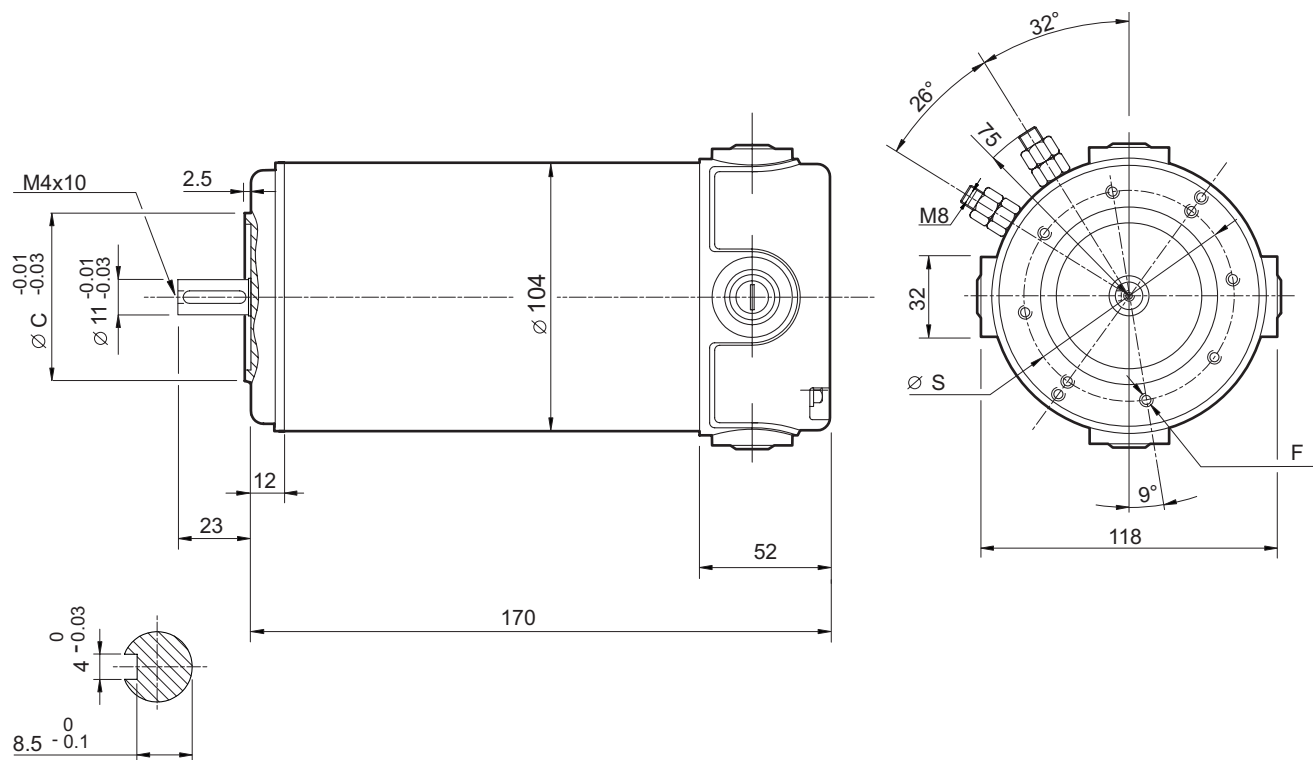

	63 B14	71 B14*
S	75	85
C (-0.03 / -0.01)	60	70
F	8 - M5	8 - M6

* Usare boccola 11/14
* Use sleeve 11/14

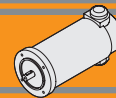

EC250.120 - EC250.240

Prestazioni

Performances

EC250.120

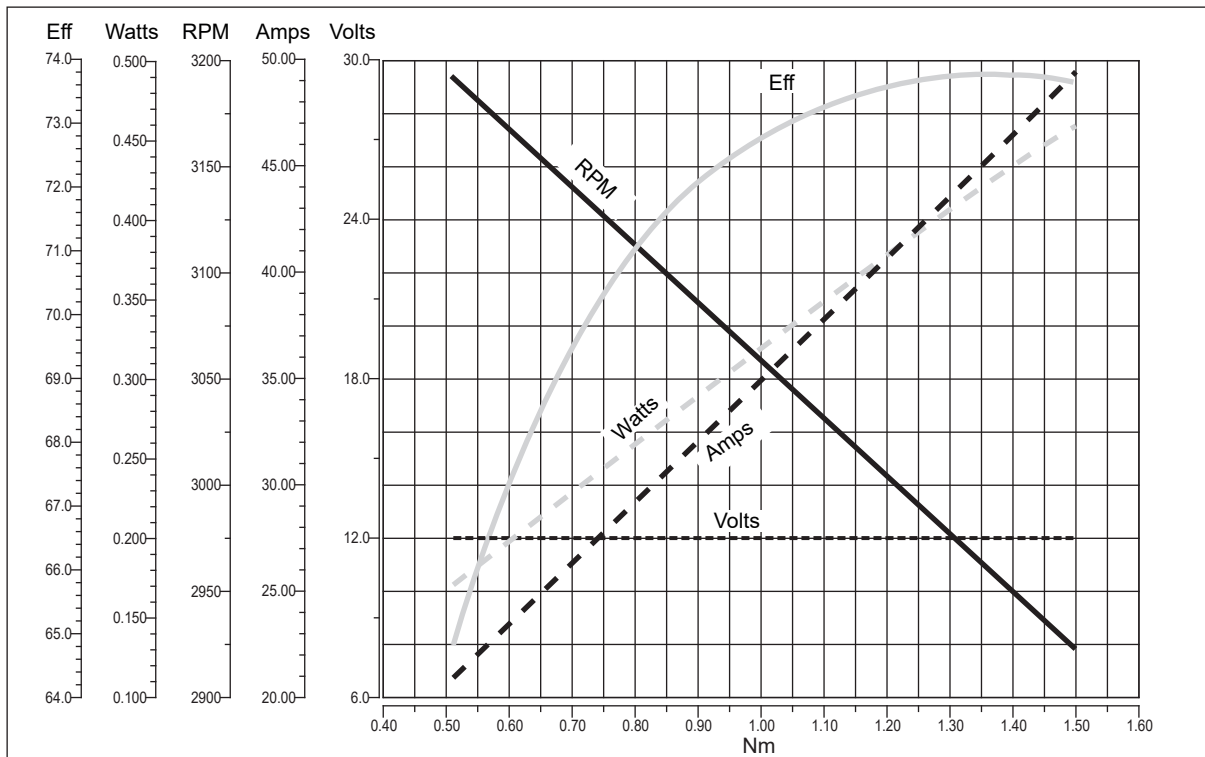

EC250.240

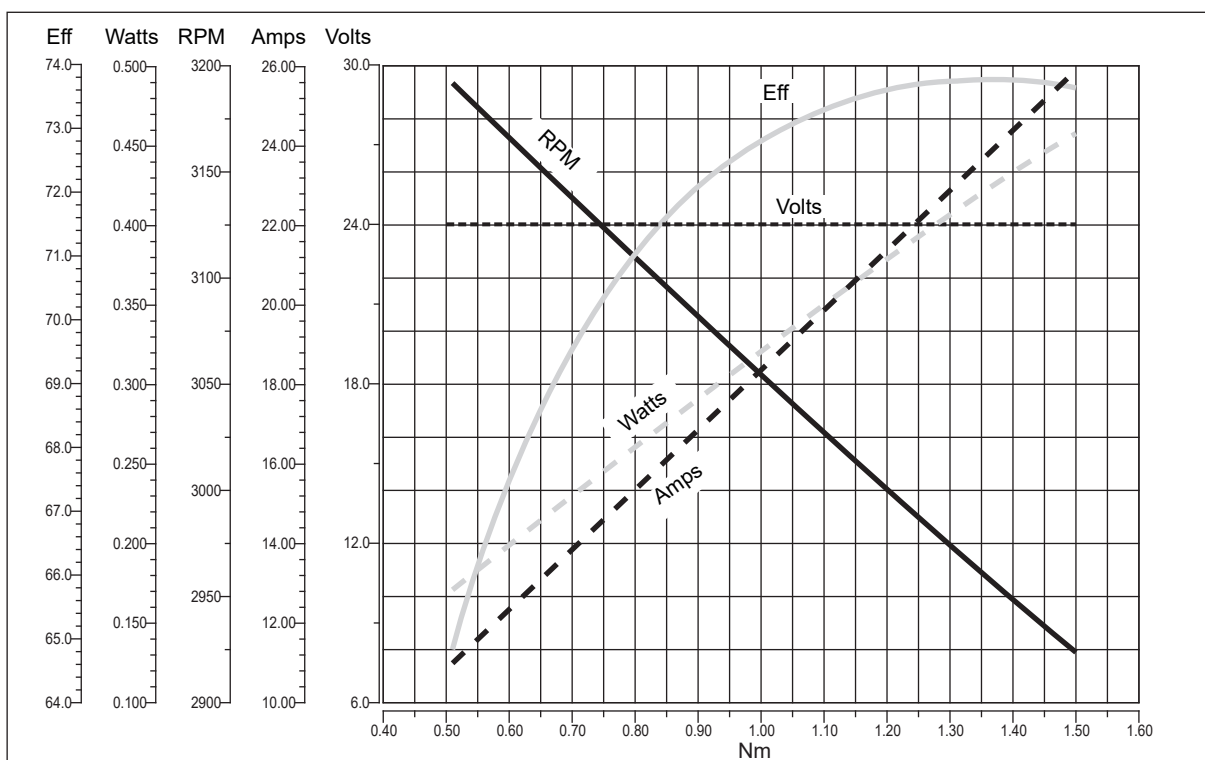

EC

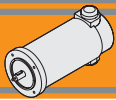

EC350.120 - EC350.240

Caratteristiche

Features

Costruzione	Tubolare, senza ventilazione
Grandezza	Ø 110 mm
Potenza	500 W S2 (350 W S1)
Magneti	4
Supporti	Cuscinetti a sfera
Fori di montaggio	8
Alimentazione	Bassa tensione, 12 o 24 Vcc
Spazzole	N° 4 di composto grafite-rame
Dimensione spazzole	LxPxH = 18.9 x 9.5 x 16.7 mm
Terminali	2 con dadi di fissaggio
Freno	Elettromagnetico

Construction	Tubular, without fan
Size	Ø 110 mm
Power	500 W S2 (350 W S1)
Magnets	4
Bearings	Ball bearings
Mounting holes	8
Power supply	Low voltage, 12 or 24 Vdc
Brushes	4 brushes made of graphite/copper composite
Brushes size	LxPxH = 18.9 x 9.5 x 16.7 mm
Leads terminals	2, with double nut
Brake	Electromagnetic

Tipo Type	S	Pn [W]	V [V]	I [A]	IC	FF	Mn [Nm]	n ₁ [min ⁻¹]	IP	Kg
EC350.120	S1	350	12	42	F	1	1.12	3000	40	5.1
	S2 30'	500		58.8			1.57			
EC350.240	S1	350	24	21			1.12		40	5.3
	S2 30'	500		29.4			1.57			

Dimensioni

Dimensions

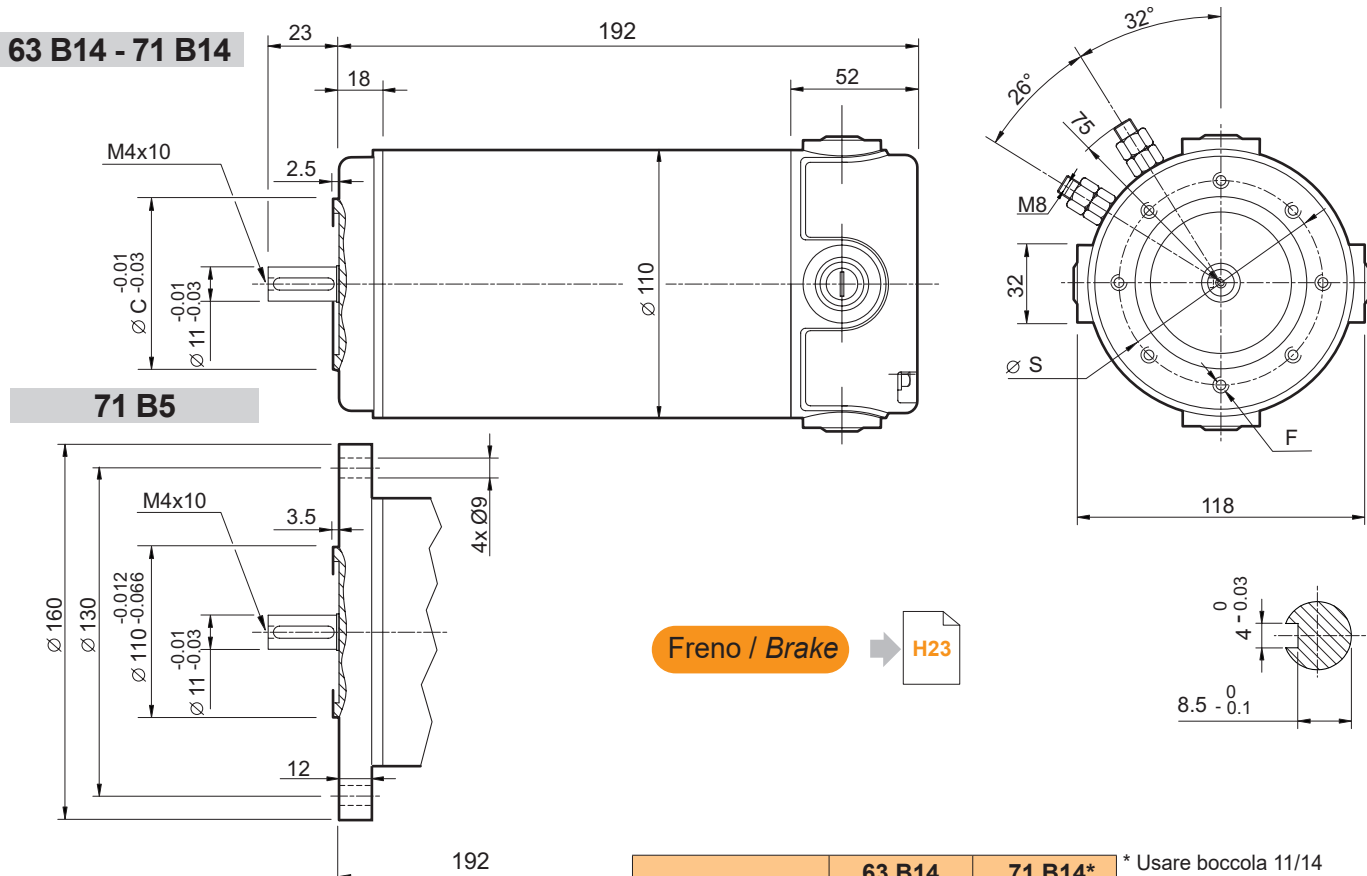

	63 B14	71 B14*
S	75	85
C (-0.03 / -0.01)	60	70
F	8 - M5	8 - M6

* Usare boccola 11/14
* Use sleeve 11/14

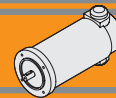

EC350.120 - EC350.240

Prestazioni

Performances

EC350.120

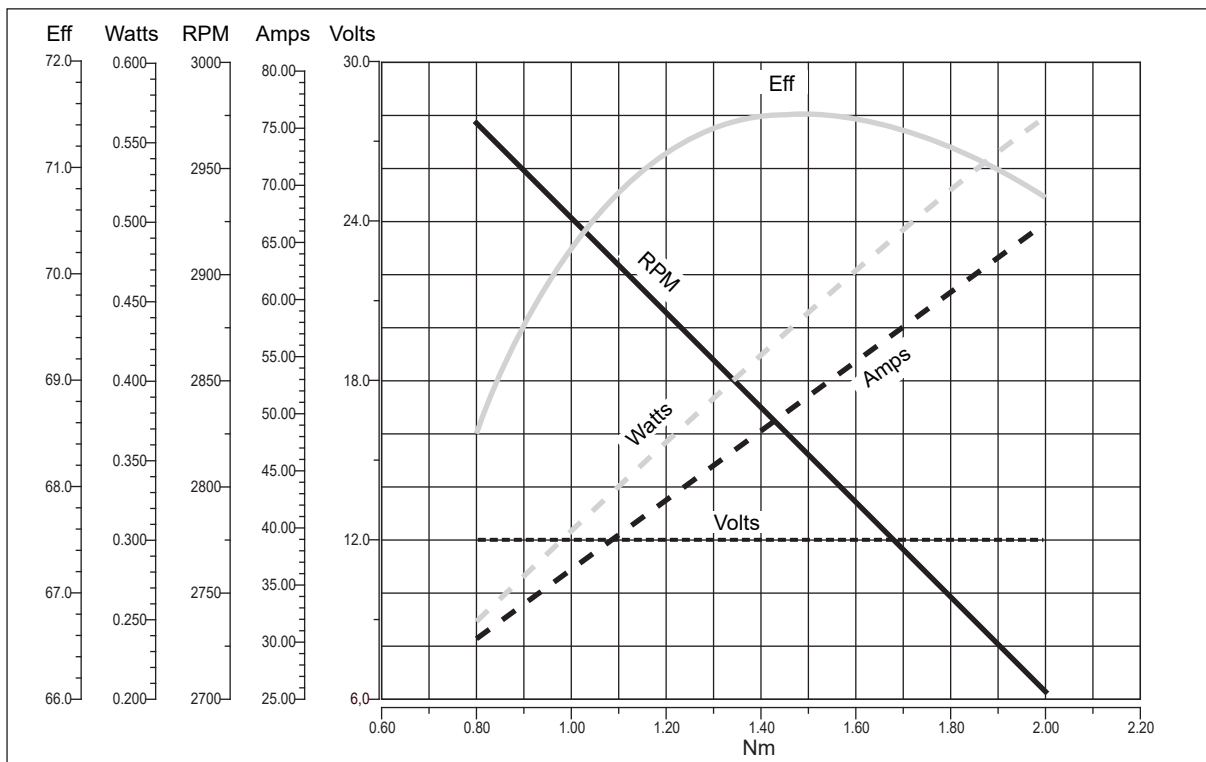

EC350.240

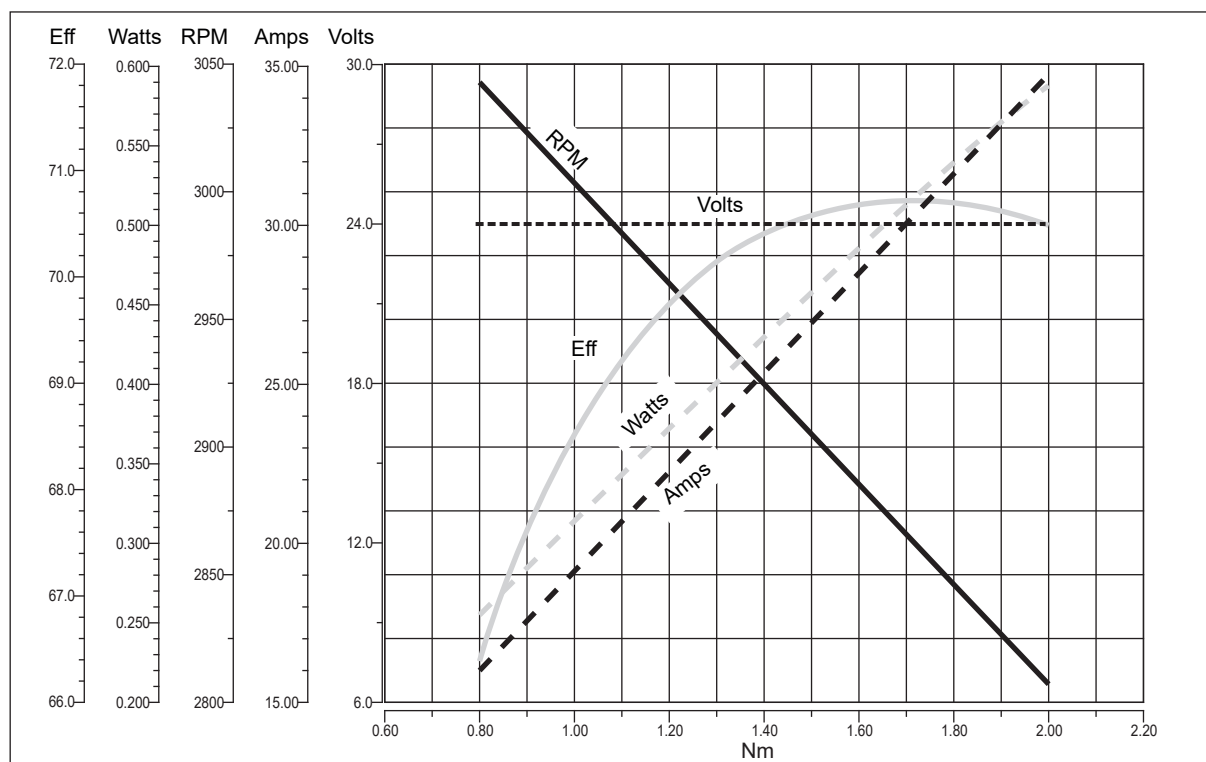

EC

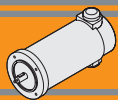

EC600.120 - EC600.240

Caratteristiche

Features

Costruzione	Tubolare, senza ventilazione
Grandezza	Ø 110 mm
Potenza	800 W S2 (600 W S1)
Magneti	4
Supporti	Cuscinetti a sfera
Fori di montaggio	8
Alimentazione	Bassa tensione, 12 o 24 Vcc
Spazzole	N° 4 di composto grafite-rame
Dimensione spazzole	LxPxH = 18.9 x 9.5 x 16.7 mm
Terminali	2 con doppio dado di fissaggio
Freno	Elettromagnetico

Construction	Tubular, without fan
Size	Ø 110 mm
Power	800 W S2 (600 W S1)
Magnets	4
Bearings	Ball bearings
Mounting holes	8
Power supply	Low voltage, 12 or 24 Vdc
Brushes	4 brushes made of graphite/copper composite
Brushes size	LxPxH = 18.9 x 9.5 x 16.7 mm
Leads terminals	2, with double nut
Brake	Electromagnetic

Tipo Type	S	Pn [W]	V [V]	I [A]	IC	FF	Mn [Nm]	n ₁ [min ⁻¹]	IP	Kg
EC600.120	S1	600	12	71	F	1	1.91	3000	40	6.6
	S2 30'	800		94.4			2.54			
EC600.240	S1	600	24	35.5			1.91		40	7.1
	S2 30'	800		47.2			2.54			

Dimensioni

Dimensions

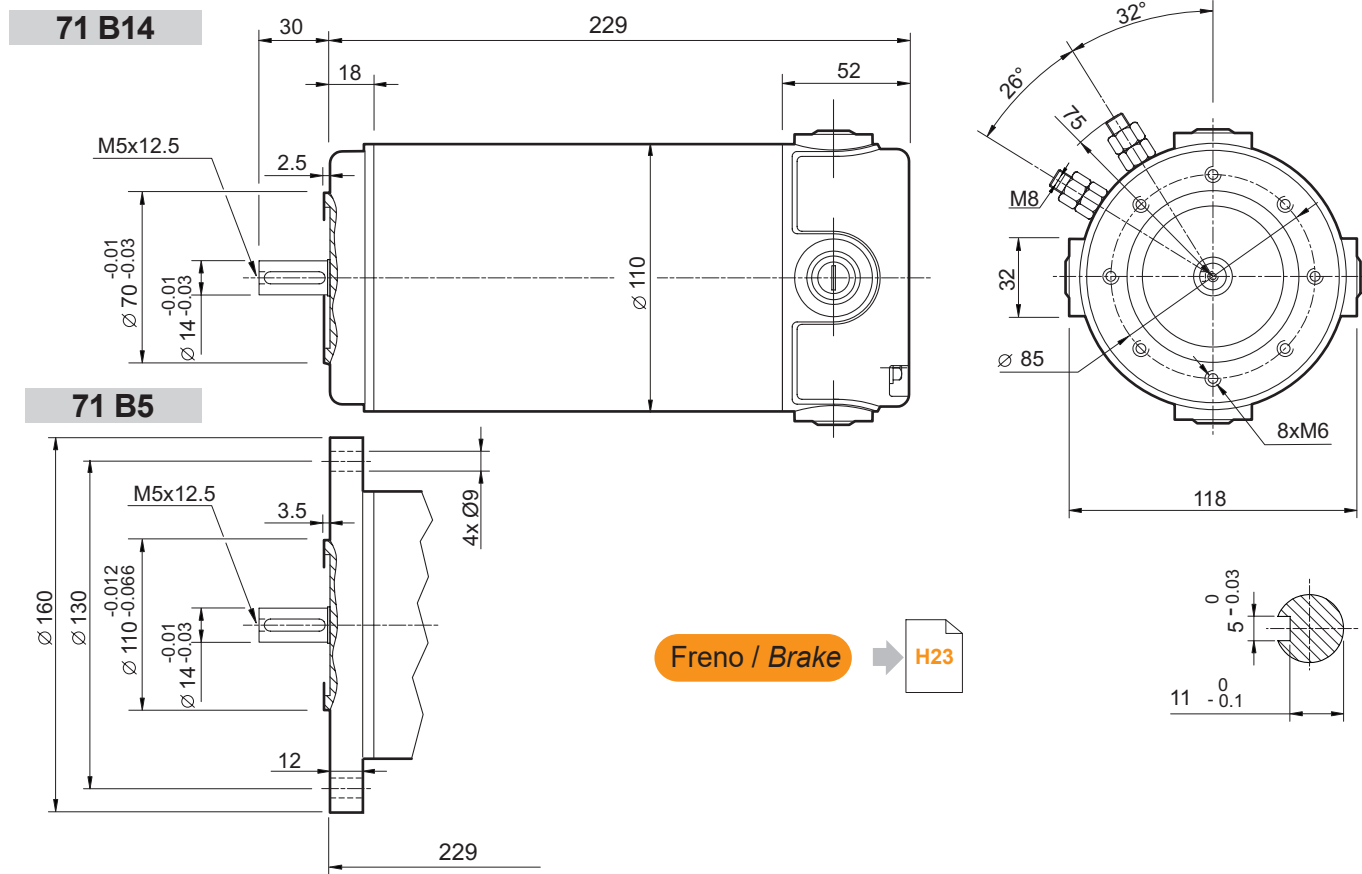

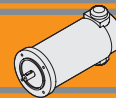

EC600.120 - EC600.240

Prestazioni

Performances

EC600.120

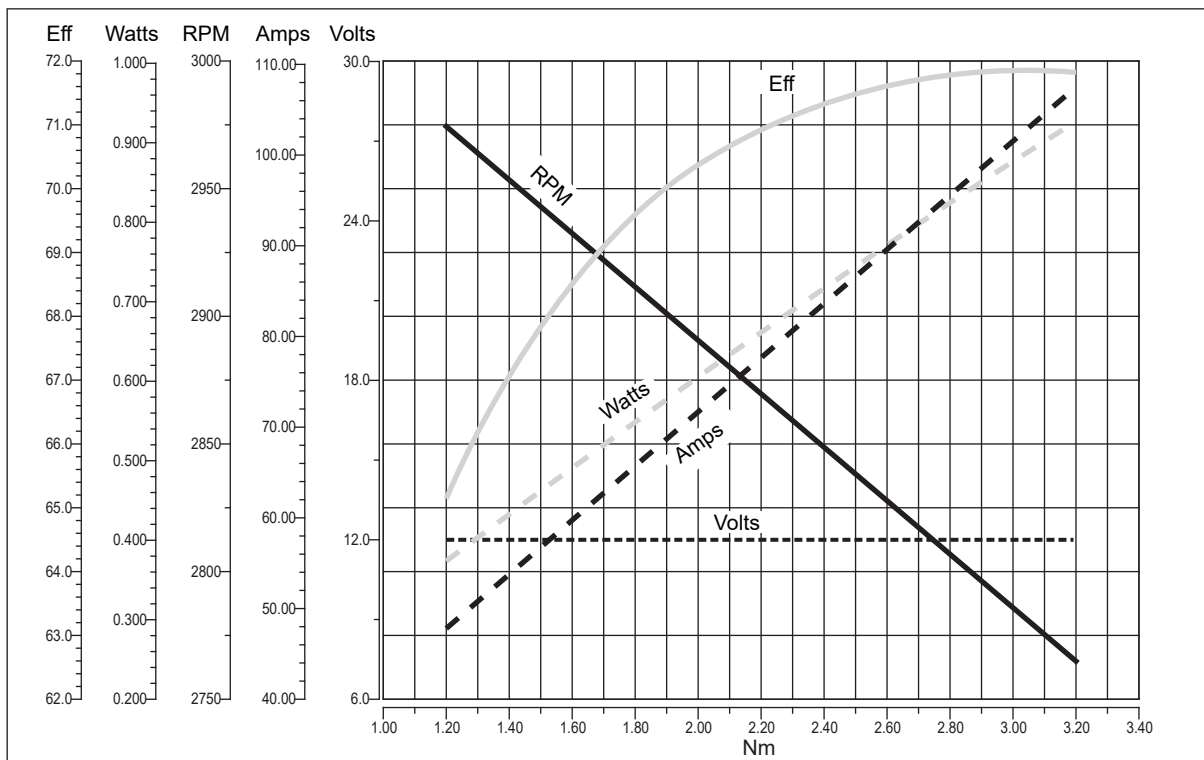

EC600.240

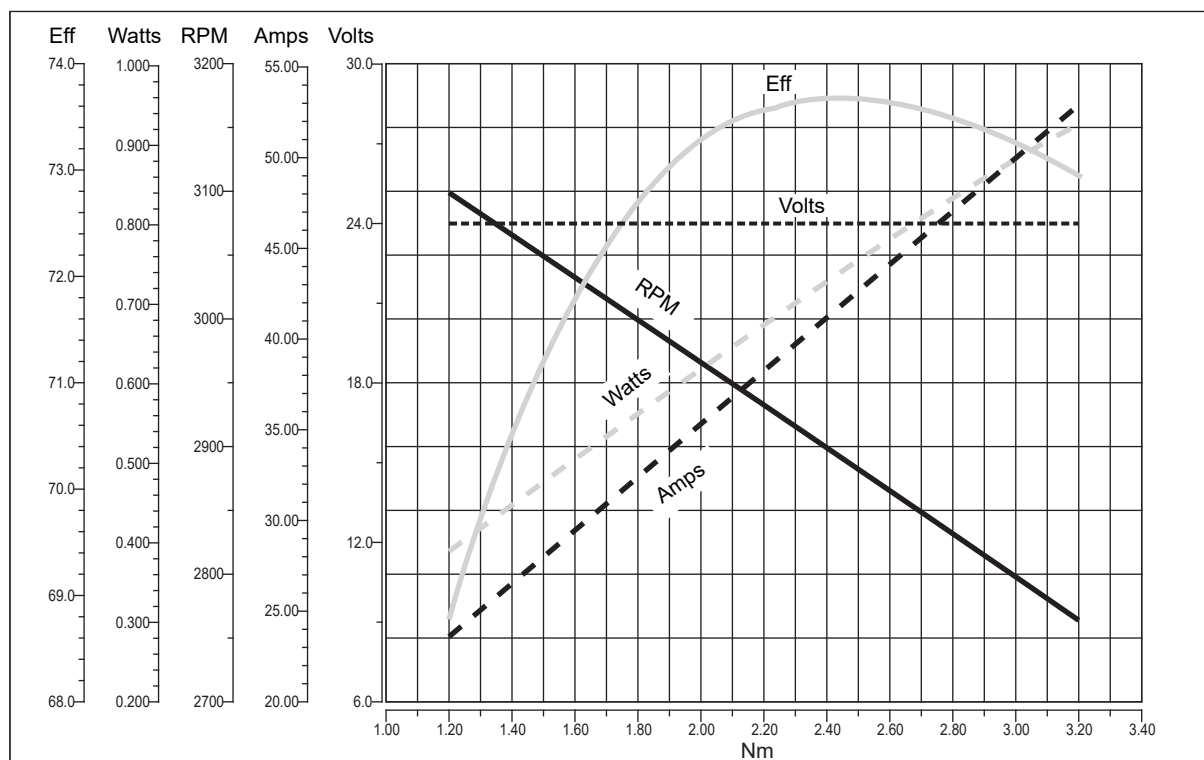

EC

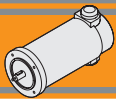

Legenda / Glossario dei grafici

Key / Diagram Glossary

Dato un motore in C.C, la velocità di rotazione è funzione lineare della coppia; così pure la corrente assorbita è una funzione lineare della coppia. Velocità e corrente variano in maniera sensibile al variare del carico.

With a D.C. motor, the rotational speed is a linear function of the torque. In the same way, the absorbed current is also a linear function of the torque. Speed and current change a lot against applied torque.

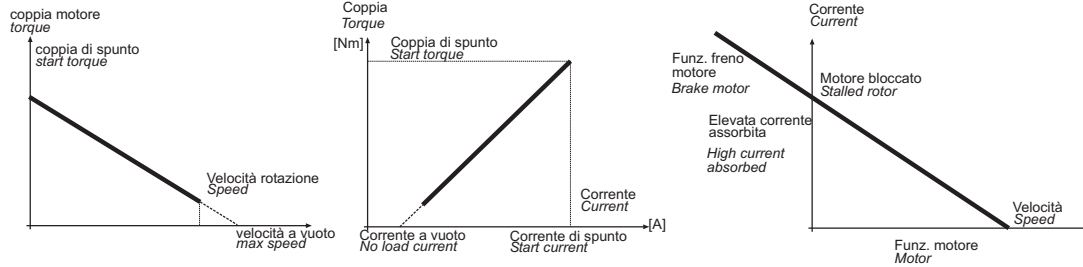

La potenza utile (potenza all' albero) si ricava dalla formula:

$$P_n [W] = M_n \cdot S = \frac{2\pi}{60} \cdot n_1 \cdot M_n$$

The output power is calculated using the formula:

$$P_n [W] = M_n \cdot S = \frac{2\pi}{60} \cdot n_1 \cdot M_n$$

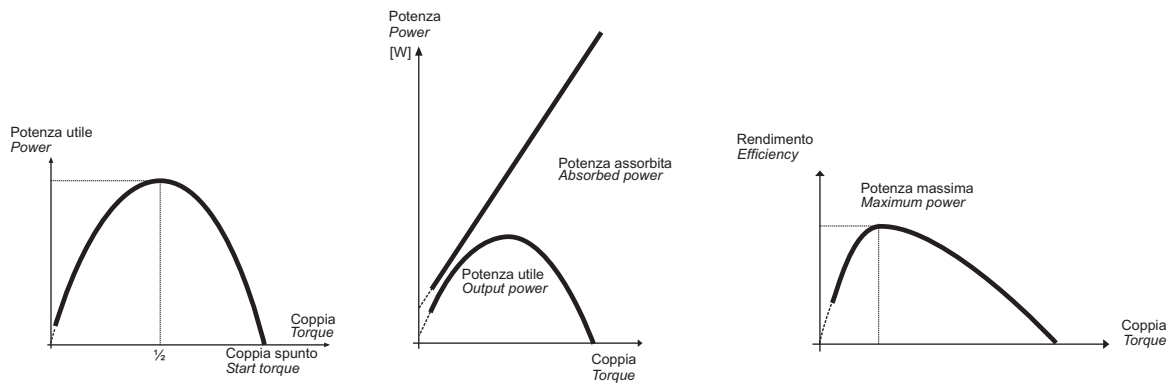

Poiché la tensione di alimentazione è costante mentre la corrente è linearmente crescente al crescere della coppia, l'andamento della potenza assorbita è un retta crescente. Dal rapporto tra la potenza meccanica e la potenza assorbita si ottiene il grafico dell'efficienza.

Since the supply voltage is constant, whereas the current increases in a linear manner as the torque increases, the absorbed power trend is a straight line going up. Efficiency is shown from the ratio between the output power and the absorbed power.

Formule utili

Useful formulas

$$\eta = \frac{P_n}{P_a}$$

$$P_a = V \cdot I$$

$$P_n = V \cdot I \cdot \eta$$

$$P_n = M_n \cdot S_v$$

$$S_v = \frac{n_1}{9.55}$$

$$[HP] \cdot 746 = [W].$$

Esempio 2 HP = circa 1500 W.

$$\eta = \frac{P_n}{P_a}$$

$$P_a = V \cdot I$$

$$P_n = V \cdot I \cdot \eta$$

$$P_n = M_n \cdot S_v$$

$$S_v = \frac{n_1}{9.55}$$

$$[HP] \cdot 746 = [W].$$

Example 2 HP = approx. 1500 W.

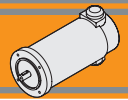

Freno

Brake

Freno / Brake

Freno con leva di sblocco/ Brake with hand release

EC050...BR
EC070...BR

EC050...BRL
EC070...BRL

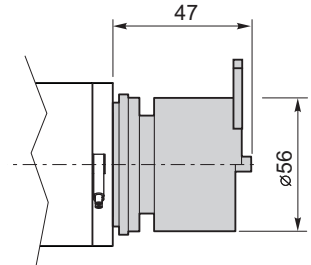
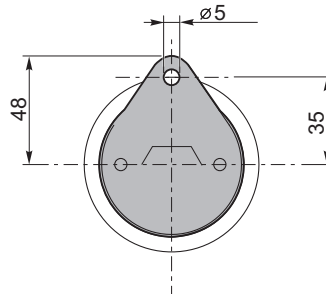
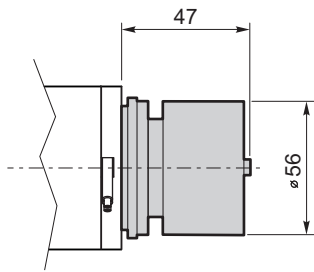

	P _n [W]	V [V]	M _n [Nm]	n ₁ [min ⁻¹]
Caratteristiche del freno / Break features	14	12 24	2	3000

EC100.24E BR
EC180.24E BR

EC100.24E BRL
EC180.24E BRL

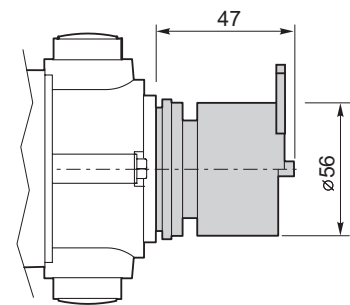
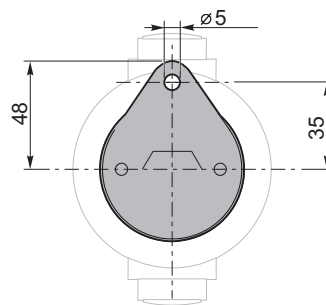
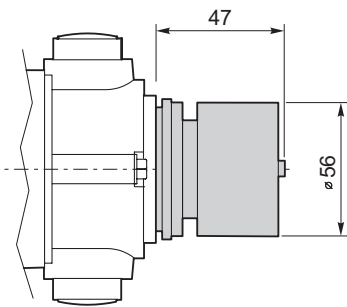

	P _n [W]	V [V]	M _n [Nm]	n ₁ [min ⁻¹]
Caratteristiche del freno / Break features	14	12 24	2	3000

EC350...BR
EC600...BR

EC350...BRL
EC600...BRL

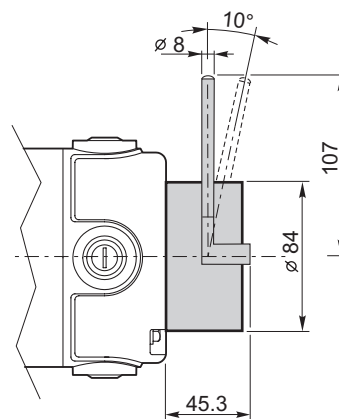
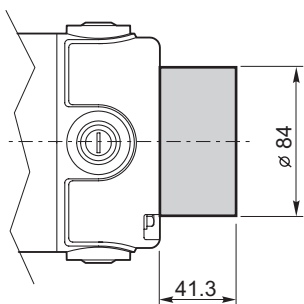

	P _n [W]	V [V]	M _n [Nm]	n ₁ [min ⁻¹]
Caratteristiche del freno / Break features	25	12 24	5	3000

EC

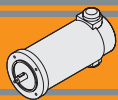

Encoder

Encoder

EC020.24E ME22

EC050.12E ME22

EC050.24E ME22

EC070.12E ME22

EC070.24E ME22

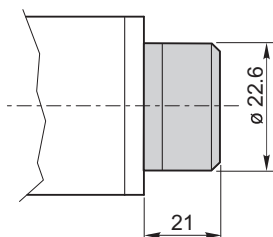

EC100.24E ME22

EC180.24E ME22

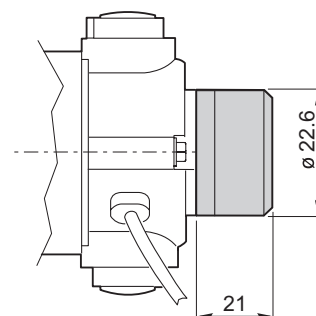

Risoluzione Encoder (CPR) / Encoder Resolution (CPR)	Numero di canali / Number of channels	Tensione d'alimentazione / Power supply
001	2	5 VdC - TTL
100		
300		

Per risoluzioni encoder non standard, si prega di contattare il nostro Servizio Tecnico.

For non-standard encoder resolution, please contact our Technical Department.

Nota: Fornito con cavo lungo 300 mm

Note: Supplie with cavle 300 mm long

TRANSTECNO[®]
the modular gearmotor

EC IP66

EC IP66



Ferrite

Motori elettrici CC IP66
IP66 DC electric motors



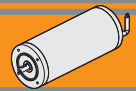

	Indice	Index	Pag. Page
EC070.120.66	Caratteristiche	<i>Features</i>	12
EC070.240.66	Dimensioni	<i>Dimensions</i>	12
	Prestazioni	<i>Performances</i>	13
EC100.120.66	Caratteristiche	<i>Features</i>	14
EC100.240.66	Dimensioni	<i>Dimensions</i>	14
	Prestazioni	<i>Performances</i>	15
EC180.120.66	Caratteristiche	<i>Features</i>	16
EC180.240.66	Dimensioni	<i>Dimensions</i>	16
	Prestazioni	<i>Performances</i>	17
EC250.120.66	Caratteristiche	<i>Features</i>	18
EC250.240.66	Dimensioni	<i>Dimensions</i>	18
	Prestazioni	<i>Performances</i>	19
EC350.120.66	Caratteristiche	<i>Features</i>	110
EC350.240.66	Dimensioni	<i>Dimensions</i>	110
	Prestazioni	<i>Performances</i>	111
EC600.120.66	Caratteristiche	<i>Features</i>	112
EC600.240.66	Dimensioni	<i>Dimensions</i>	112
	Prestazioni	<i>Performances</i>	113

Questa sezione annulla e sostituisce ogni precedente edizione o revisione. Qualora questa sezione non Vi sia giunta in distribuzione controllata, l'aggiornamento dei dati ivi contenuto non è assicurato. **In tal caso la versione più aggiornata è disponibile sul nostro sito internet www.transtecno.com**

*This section replaces any previous edition and revision. If you obtained this catalogue other than through controlled distribution channels, the most up to date content is not guaranteed. **In this case the latest version is available on our web site www.transtecno.com***

**EC IP66**Motori elettrici CC
DC Electric motors**EC070.120.66 - EC070.240.66****Caratteristiche****Features**

Costruzione	Tubolare, senza ventilazione
Grandezza	Ø 65 mm
Potenza	100 W S2 (70 W S1)
Magneti	2
Supporti	Cuscinetti a sfera
Fori di montaggio	4
Alimentazione	Bassa tensione, 12 o 24 Vcc
Spazzole	N° 2 interne di composto grafite-rame
Cavo di alimentazione	Lunghezza: 1000 mm

Construction	Tubular, without fan
Size	Ø 65 mm
Power	100 W S2 (70 W S1)
Magnets	2
Bearings	Ball bearings
Mounting holes	4
Power supply	Low voltage, 12 or 24 Vdc
Brushes	2 inside brushes made of graphite/copper composite
Electric cable	Length: 1000 mm

Tipo Type	S	Pn [W]	V [V]	I [A]	IC	FF	Mn [Nm]	n ₁ [min ⁻¹]	IP	Kg
EC070.120.66	S1	70	12	8.4	F	1	0.22	3000	66	1.7
	S2 30'	100		11.8			0.31			
EC070.240.66	S1	70	24	4.2			0.22			
	S2 30'	100		5.9			0.31			

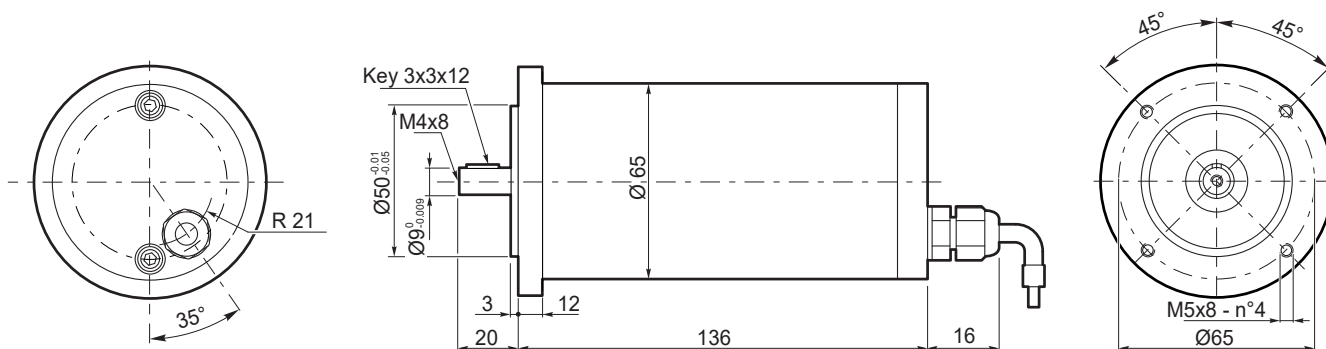
Dimensioni**Dimensions****EC070.120.66****EC070.240.66**



EC070.120.66 - EC070.240.66

Prestazioni

Performances

EC070.120.66

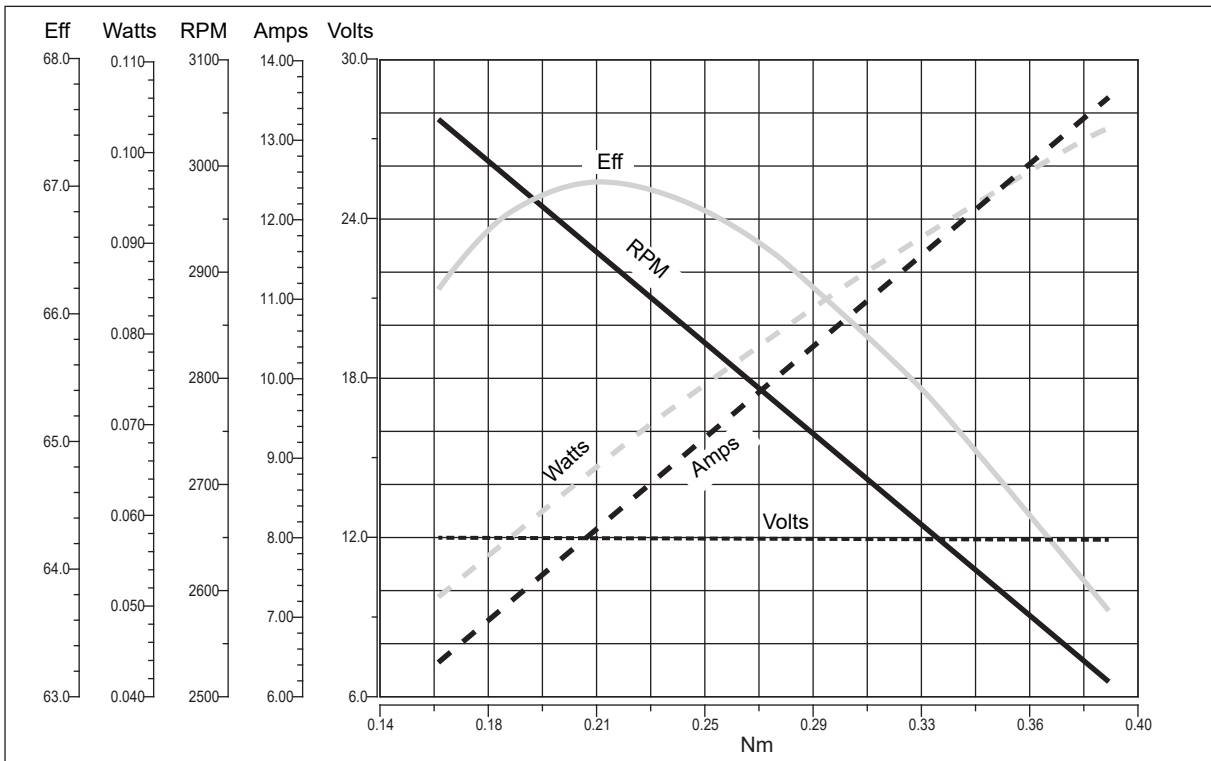

EC IP66

EC070.240.66

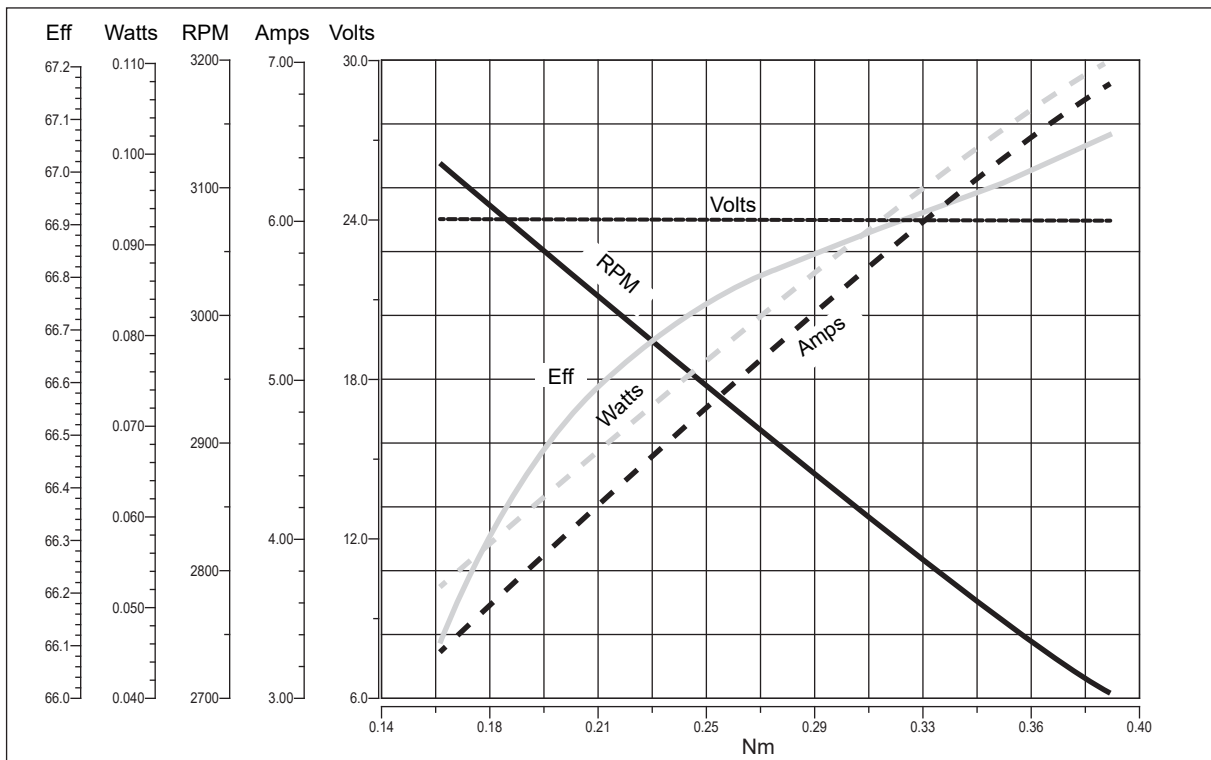



EC100.120.66 - EC100.240.66

Caratteristiche

Features

Costruzione	Tubolare, senza ventilazione
Grandezza	Ø 80 mm
Potenza	140 W S2 (100 W S1)
Magneti	2
Supporti	Cuscinetti a sfera
Fori di montaggio	4
Alimentazione	Bassa tensione, 12 o 24 Vcc
Cavo di alimentazione	Lunghezza: 1000 mm

Construction	Tubular, without fan
Size	Ø 80 mm
Power	140 W S2 (100 W S1)
Magnets	2
Bearings	Ball bearings
Mounting holes	4
Power supply	Low voltage, 12 or 24 Vdc
Electric cable	Length: 1000 mm

Tipo Type	S	Pn [W]	V [V]	I [A]	IC	FF	Mn [Nm]	n ₁ [min ⁻¹]	IP	Kg
EC100.120.66	S1	100	12	12	F	1	0.31	3000	66	2.7
	S2 25'	140		16.8			0.43			
EC100.240.66	S1	100	24	6						
	S2 25'	140		8.4			0.43			

Dimensioni

Dimensions

EC100.120.66 EC100.240.66

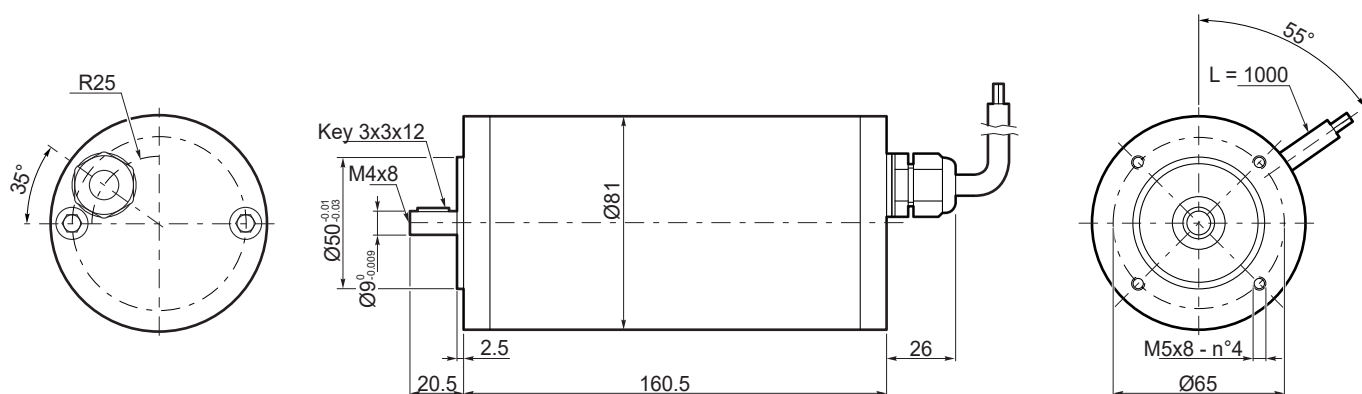



EC100.120.66

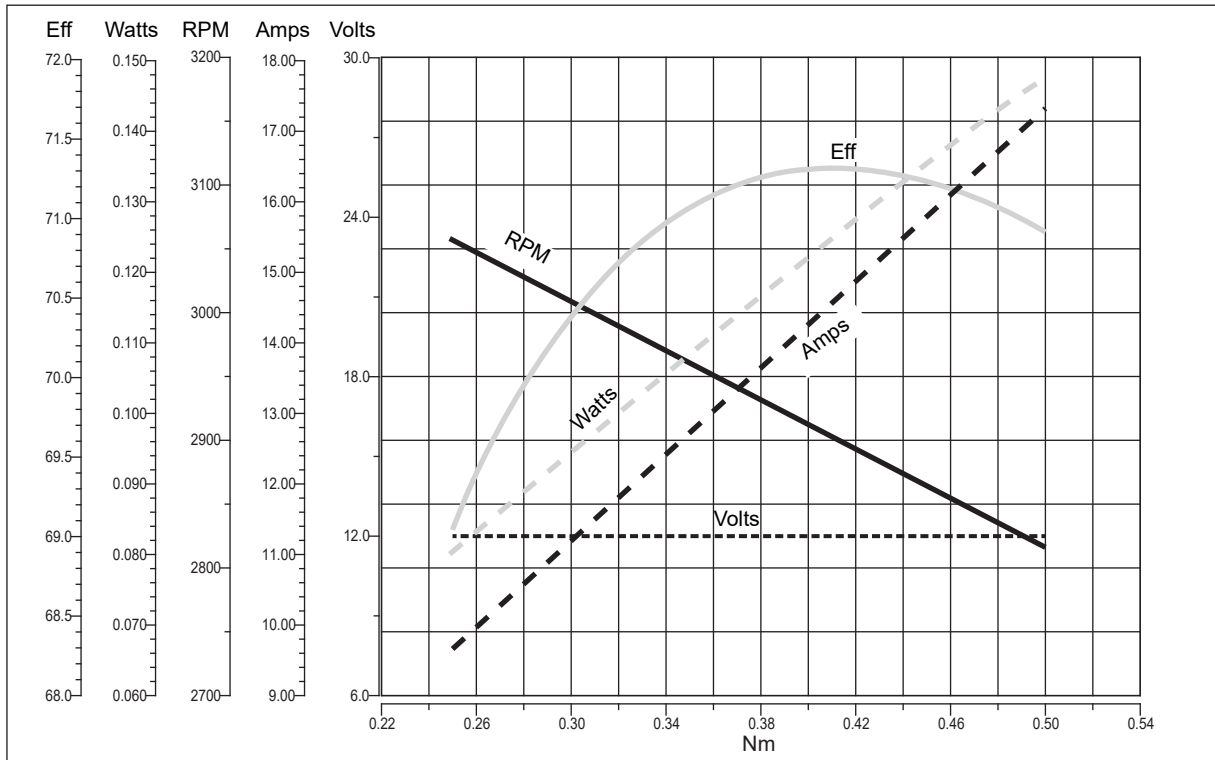

EC IP66

EC100.240.66

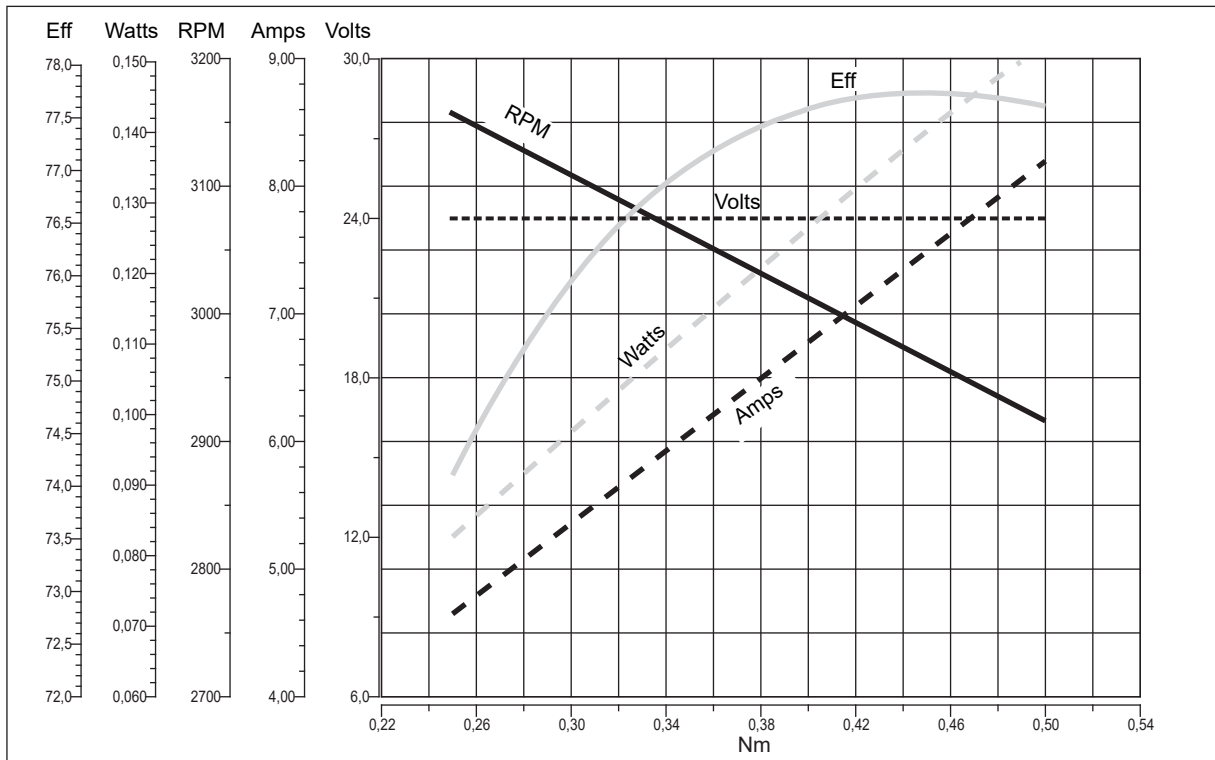



EC180.120.66 - EC180.240.66

Caratteristiche

Features

Costruzione	Tubolare, senza ventilazione
Grandezza	Ø 80 mm
Potenza	250 W S2 (180 W S1)
Magneti	2
Supporti	Cuscinetti a sfera
Fori di montaggio	4
Alimentazione	Bassa tensione, 12 o 24 Vcc
Cavo di alimentazione	Lunghezza: 1000 mm

Construction	Tubular, without fan
Size	Ø 80 mm
Power	250 W S2 (180 W S1)
Magnets	2
Bearings	Ball bearings
Mounting holes	4
Power supply	Low voltage, 12 or 24 Vdc
Electric cable	Length: 1000 mm

Tipo Type	S	Pn [W]	V [V]	I [A]	IC	FF	Mn [Nm]	n ₁ [min ⁻¹]	IP	Kg
EC180.120.66	S1	180	12	21.5	F	1	0.57	3000	66	3.4
	S2 25'	250		30			0.8			
EC180.240.66	S1	180	24	10.8						
	S2 25'	250		15			0.8			

Dimensioni

Dimensions

EC180.120.66

EC180.240.66

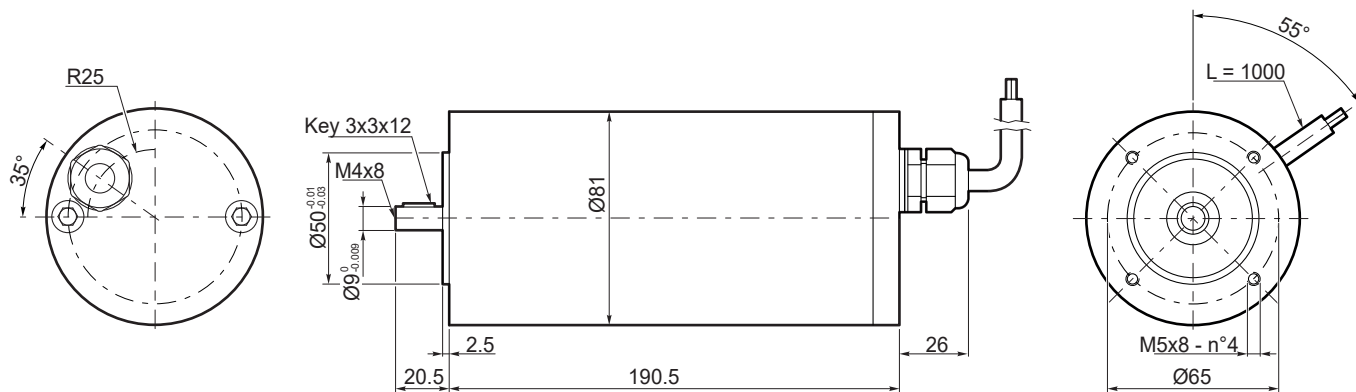



EC180.120.66

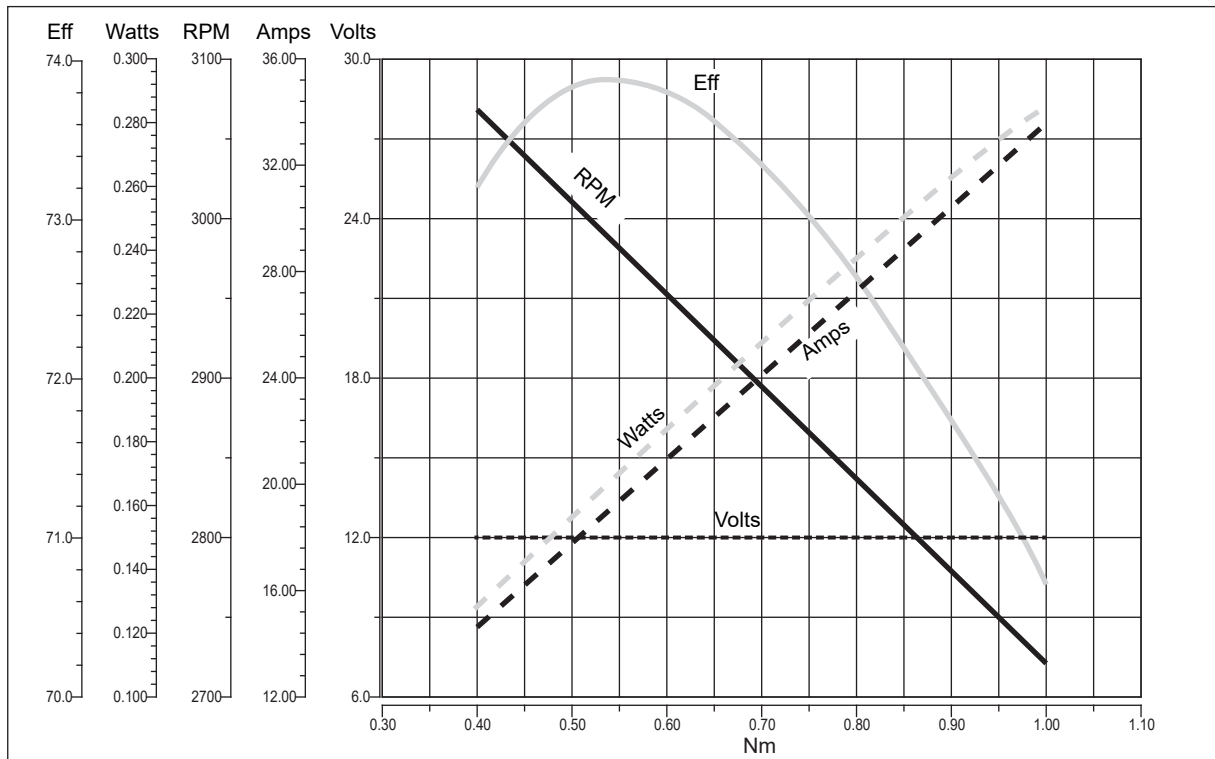

EC IP66

EC180.240.66

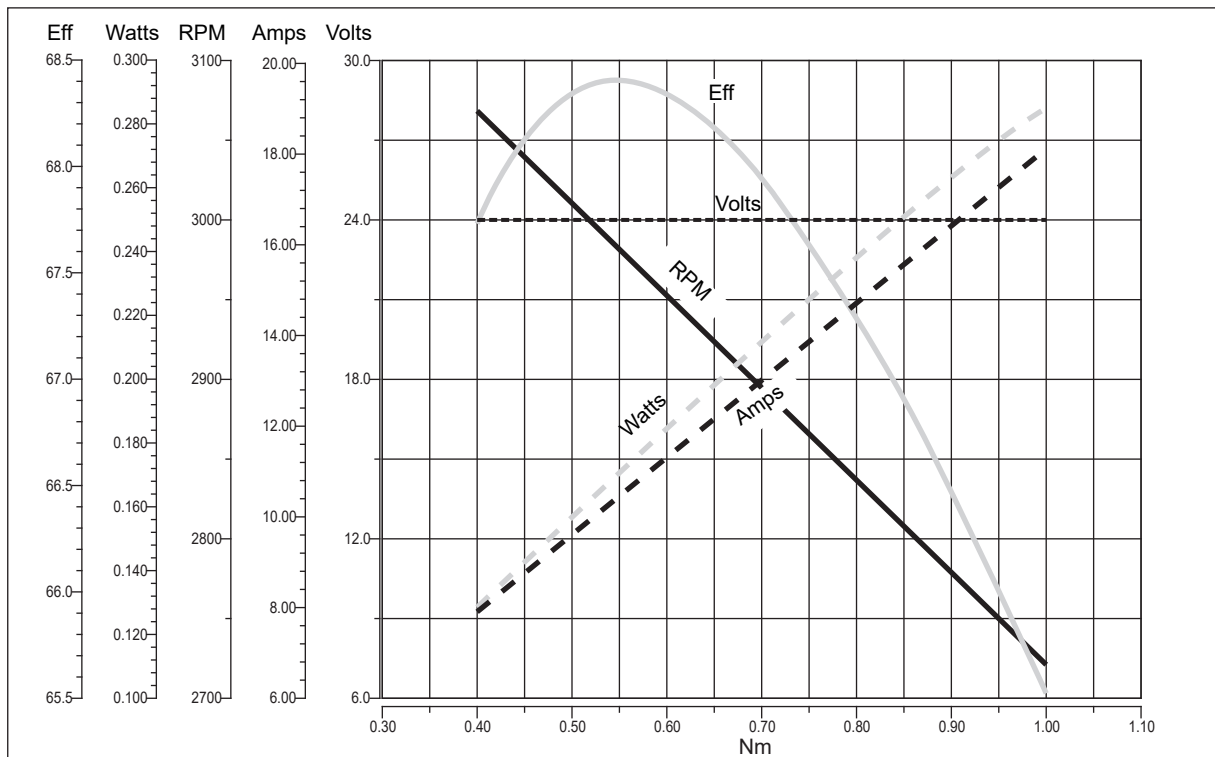



EC250.120.66 - EC250.240.66

Caratteristiche

Features

Costruzione	Tubolare, senza ventilazione
Grandezza	Ø 104 mm
Potenza	350 W S2 (250 W S1)
Magneti	4
Supporti	Cuscinetti a sfera
Fori di montaggio	8
Alimentazione	Bassa tensione, 12 o 24 Vcc
Terminali	2 con doppio dado di fissaggio

Construction	Tubular, without fan
Size	Ø 104 mm
Power	350 W S2 (250 W S1)
Magnets	4
Bearings	Ball bearings
Mounting holes	8
Power supply	Low voltage, 12 or 24 Vdc
Leads terminals	2, with double nut

Tipo Type	S	Pn [W]	V [V]	I [A]	IC	FF	Mn [Nm]	n ₁ [min ⁻¹]	IP	Kg
EC250.120.66	S1	250	12	30	F	1	0.8	3000	66	4.15
	S2 25'	350		38.5			1.12			
EC250.240.66	S1	250	24	15			0.8			
	S2 25'	350		20.5			1.12			

Dimensioni

Dimensions

EC250.120.66

EC250.240.66

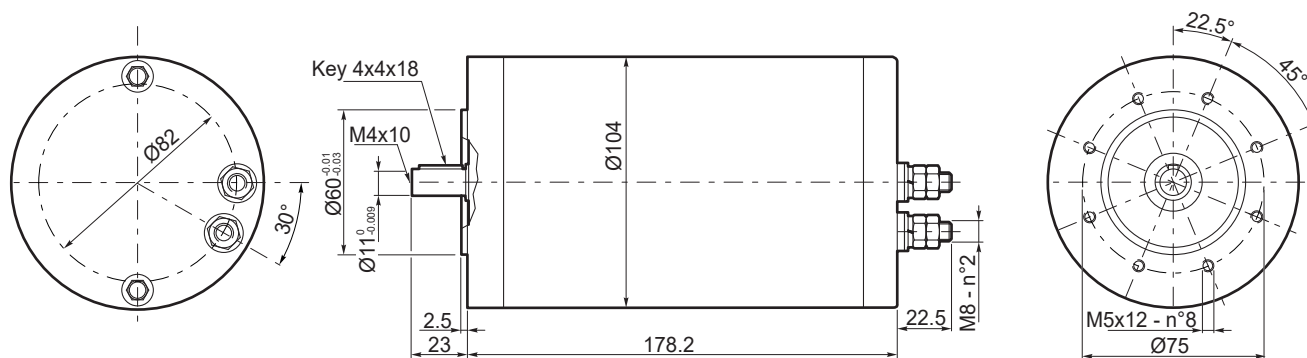



EC250.120.66

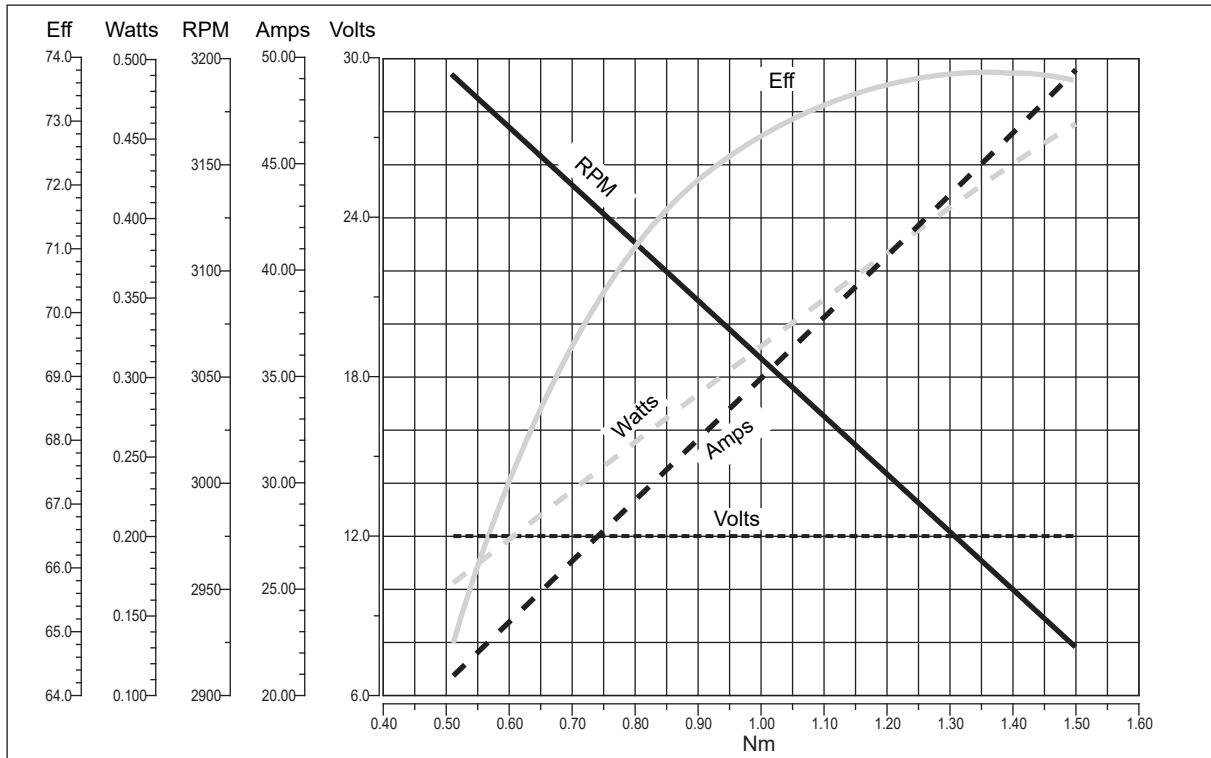

EC IP66

EC250.240.66

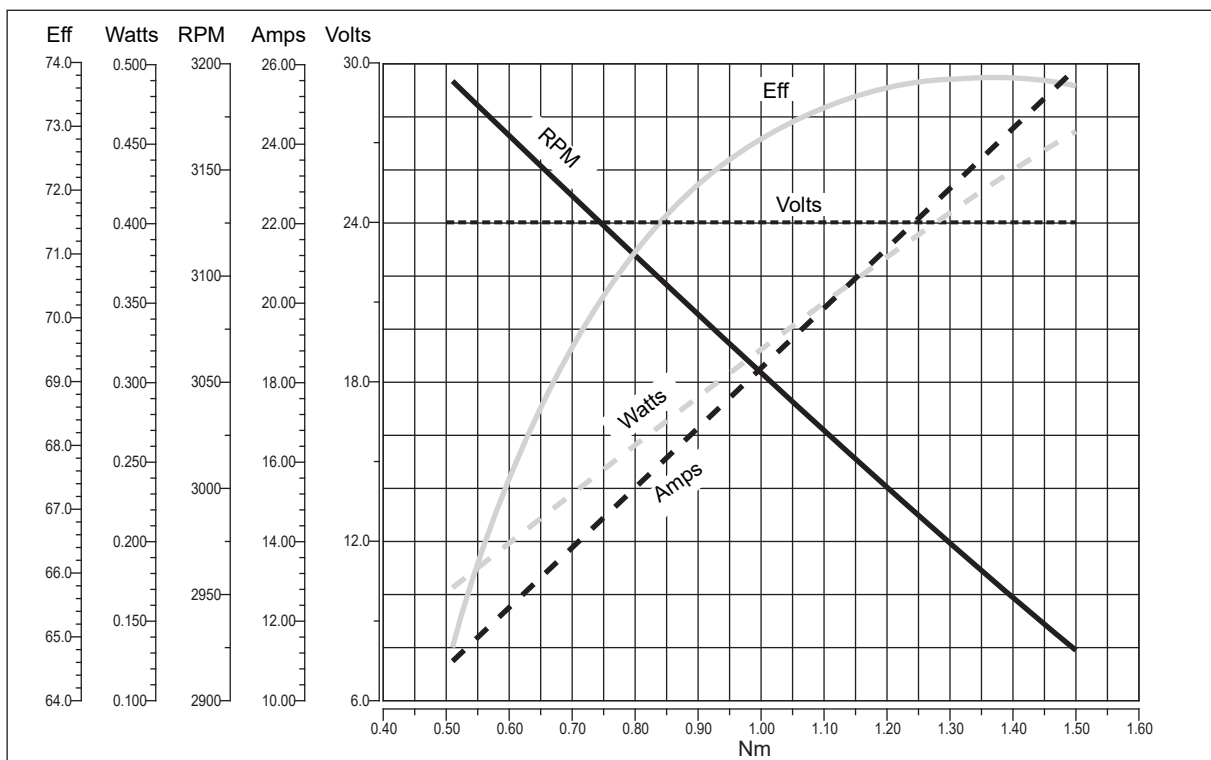



EC350.120.66 - EC350.240.66

Caratteristiche

Features

Costruzione	Tubolare, senza ventilazione
Grandezza	Ø 110 mm
Potenza	500 W S2 (350 W S1)
Magneti	4
Supporti	Cuscinetti a sfera
Fori di montaggio	8
Alimentazione	Bassa tensione, 12 o 24 Vcc
Terminali	2 con dadi di fissaggio

Construction	Tubular, without fan
Size	Ø 110 mm
Power	500 W S2 (350 W S1)
Magnets	4
Bearings	Ball bearings
Mounting holes	8
Power supply	Low voltage, 12 or 24 Vdc
Leads terminals	2, with double nut

Tipo Type	S	Pn [W]	V [V]	I [A]	IC	FF	Mn [Nm]	n ₁ [min ⁻¹]	IP	Kg
EC350.120.66	S1	350	12	42	F	1	1.12	3000	66	5.1
	S2 30'	500		58.8			1.57			
EC350.240.66	S1	350	24	21			1.12			5.3
	S2 30'	500		29.4			1.57			

Dimensioni

Dimensions

EC350.120.66
EC350.240.66

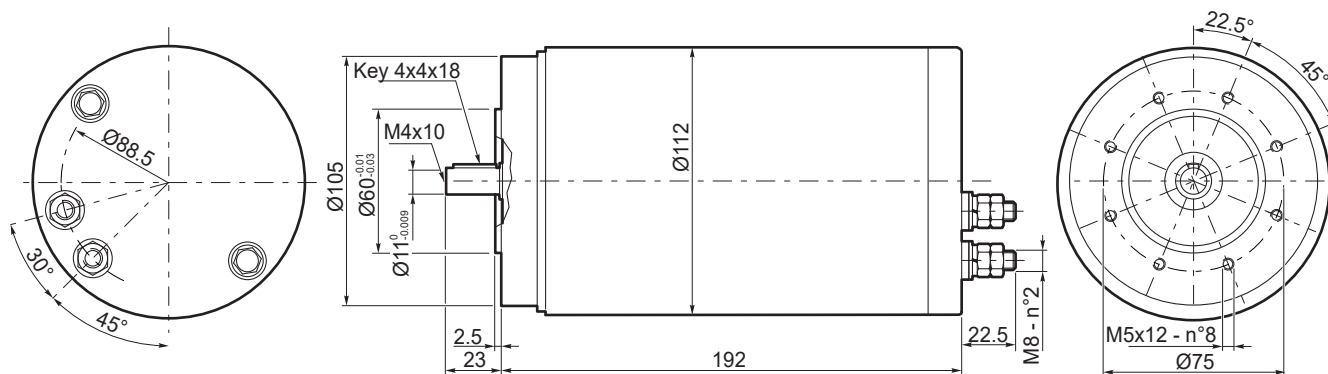



EC350.120.66

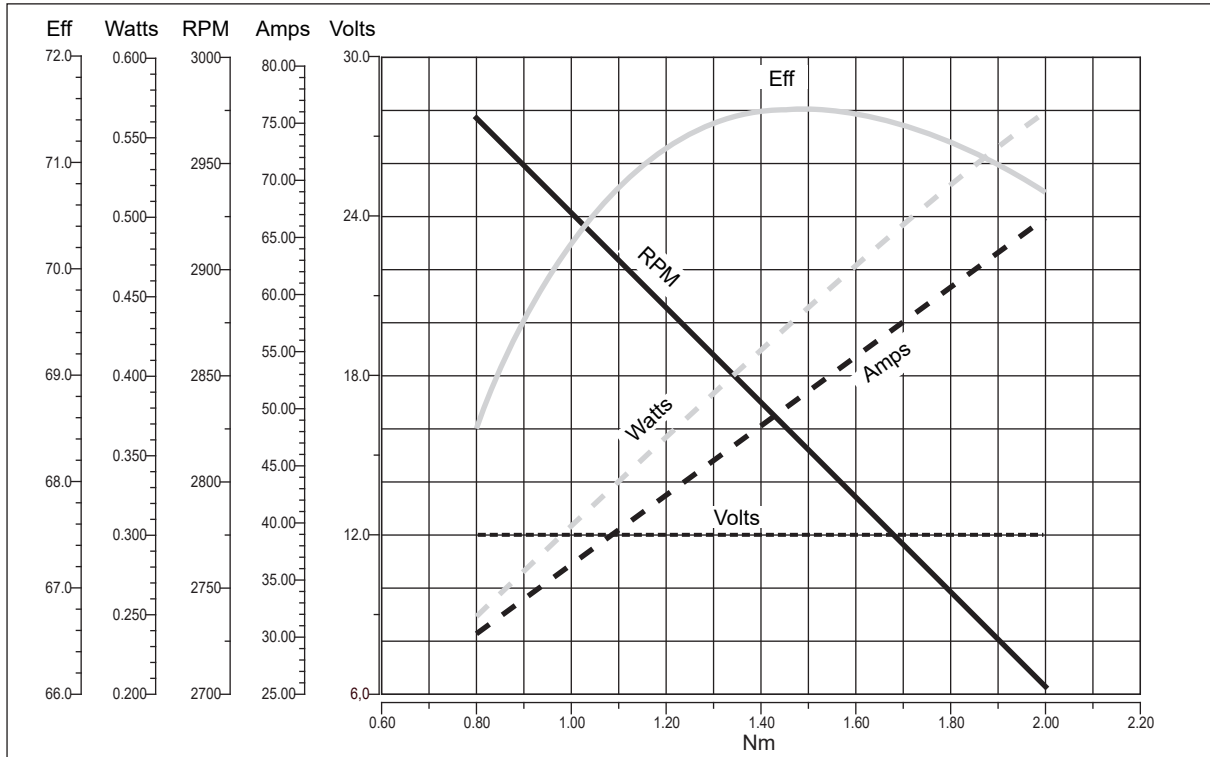

EC IP66

EC350.240.66

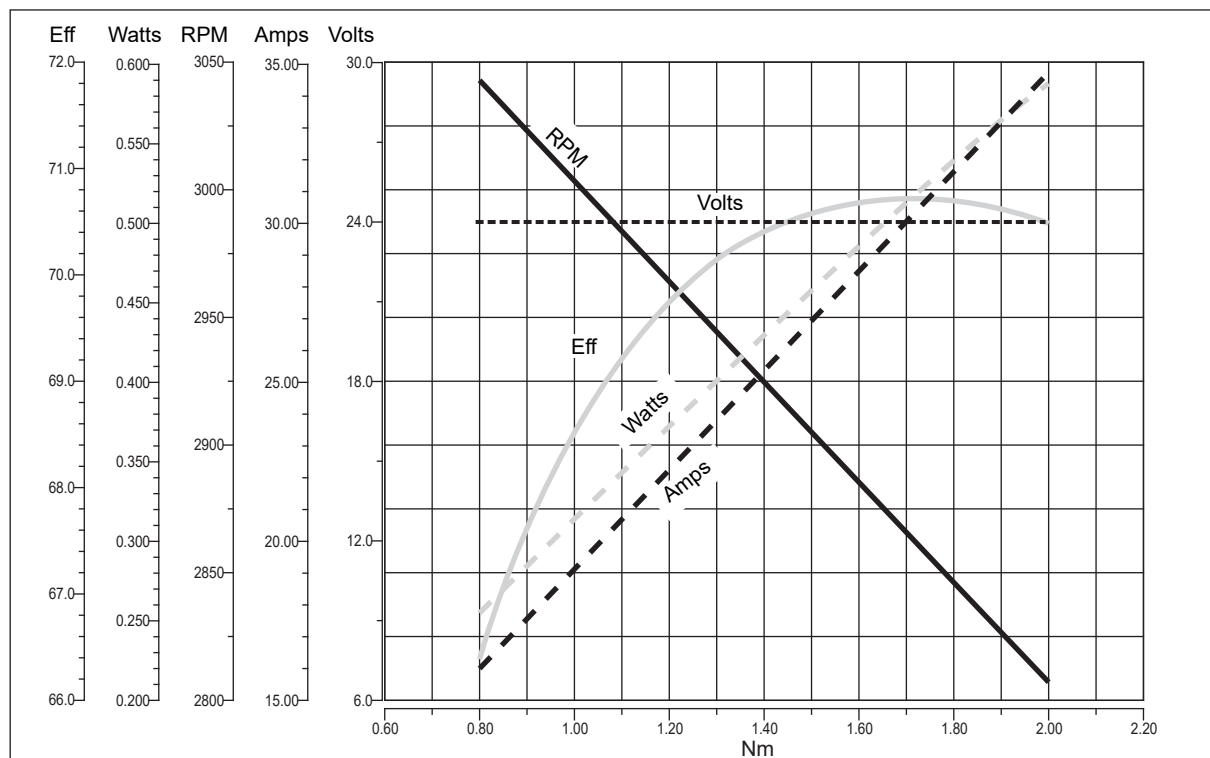



EC600.120.66 - EC600.240.66

Caratteristiche

Features

Costruzione	Tubolare, senza ventilazione
Grandezza	Ø 110 mm
Potenza	800 W S2 (600 W S1)
Magneti	4
Supporti	Cuscinetti a sfera
Fori di montaggio	8
Alimentazione	Bassa tensione, 12 o 24 Vcc
Terminali	2 con doppio dado di fissaggio

Construction	Tubular, without fan
Size	Ø 110 mm
Power	800 W S2 (600 W S1)
Magnets	4
Bearings	Ball bearings
Mounting holes	8
Power supply	Low voltage, 12 or 24 Vdc
Leads terminals	2, with double nut

Tipo Type	S	Pn [W]	V [V]	I [A]	IC	FF	Mn [Nm]	n ₁ [min ⁻¹]	IP	Kg
EC600.120.66	S1	600	12	71	F	1	1.91	3000	66	6.6
	S2 30'	800		94.4			2.54			
EC600.240.66	S1	600	24	35.5			1.91			7.1
	S2 30'	800		47.2			2.54			

Dimensioni

Dimensions

EC600.120.66

EC600.240.66

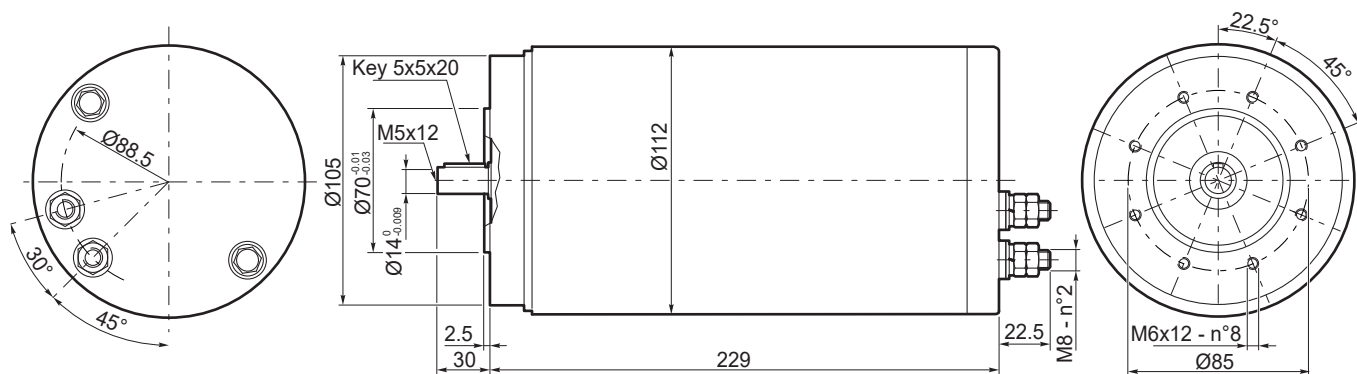



EC600.120.66

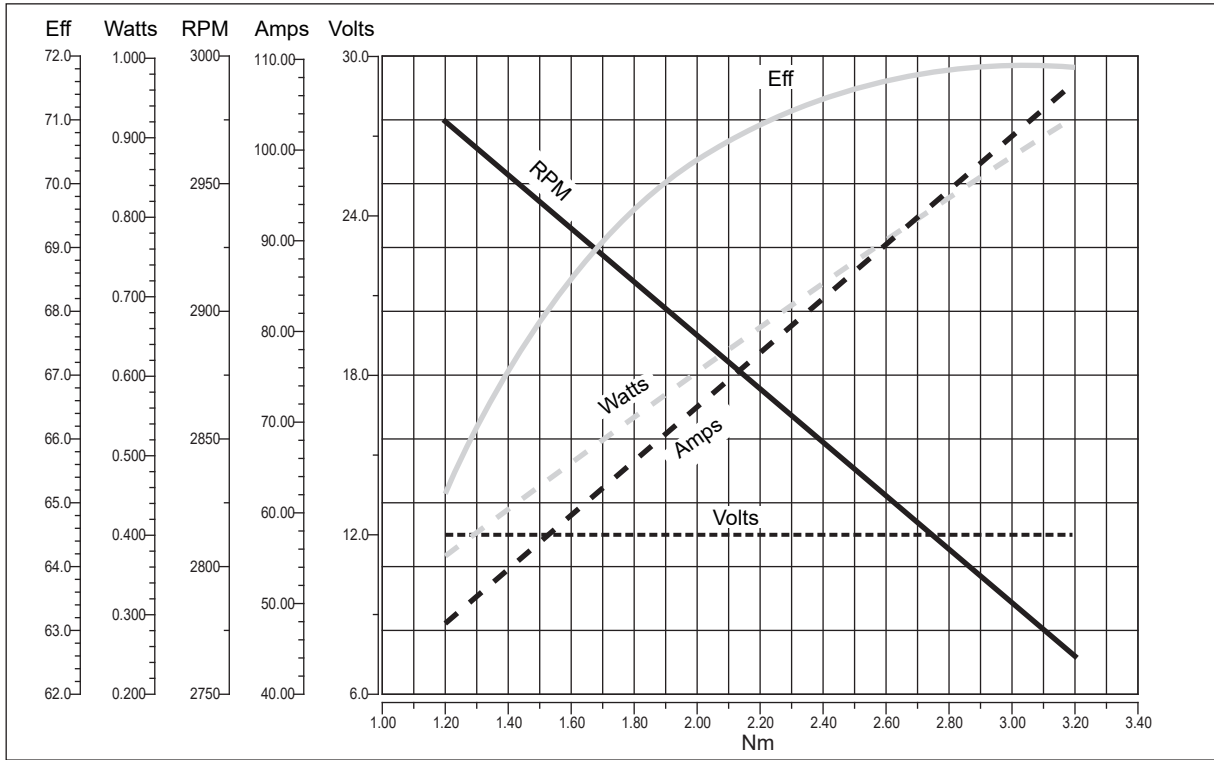

EC IP66

EC600.240.66

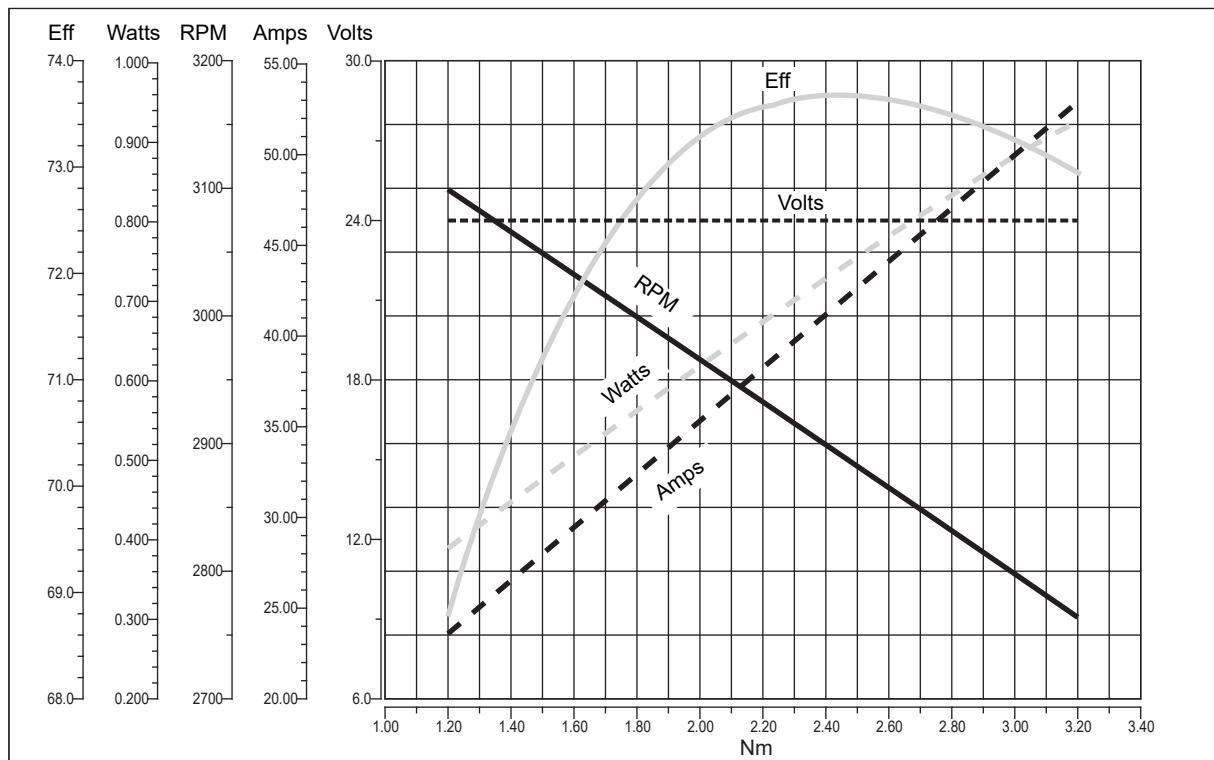



Ferrite

Motoriduttori CC ad ingranaggi cilindrici
DC helical in-line gearmotors



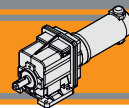

Indice	Index	Pag. Page
Caratteristiche tecniche	<i>Technical features</i>	L2
Designazione	<i>Classification</i>	L2
Sensi di rotazione	<i>Direction of rotation</i>	L3
Lubrificazione	<i>Lubrication</i>	L3
Simbologia	<i>Symbols</i>	L3
Carichi radiali	<i>Radial loads</i>	L4
Motori applicabili	<i>IEC Motor adapters</i>	L4
Dati tecnici per servizio S2	<i>Technical data for S2 duty</i>	L5
Dimensioni	<i>Dimensions</i>	L9

Questa sezione annulla e sostituisce ogni precedente edizione o revisione. Qualora questa sezione non Vi sia giunta in distribuzione controllata, l'aggiornamento dei dati ivi contenuto non è assicurato. **In tal caso la versione più aggiornata è disponibile sul nostro sito internet www.transtecno.com**

This section replaces any previous edition and revision. If you obtained this catalogue other than through controlled distribution channels, the most up to date content is not guaranteed. In this case the latest version is available on our web site www.transtecno.com

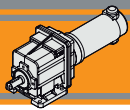

Caratteristiche tecniche

Le caratteristiche principali dei motoriduttori CC ad ingranaggi cilindrici a magneti permanenti in ferrite serie ECMG sono:

- Alimentazione in bassa tensione 12/24 Vcc
- Possibilità di montaggio encoder
- Potenze motore disponibili da 100 a 800W S2
- Magneti in ferrite
- Carcasse dei riduttori in pressofusione di alluminio
- Lubrificazione permanente con olio sintetico
- Ingranaggi sempre rettificati

Technical features

The main features of ECMG ferrite permanent magnets DC helical in-line gearmotors range are:

- Low voltage power supply 12/24 Vdc
- Suitable for encoder assembly
- Motor power ratings available from 100 to 800W S2
- Ferrite magnets
- Die-cast aluminum housing
- Permanent synthetic oil long-life lubrication
- Ground helical gears

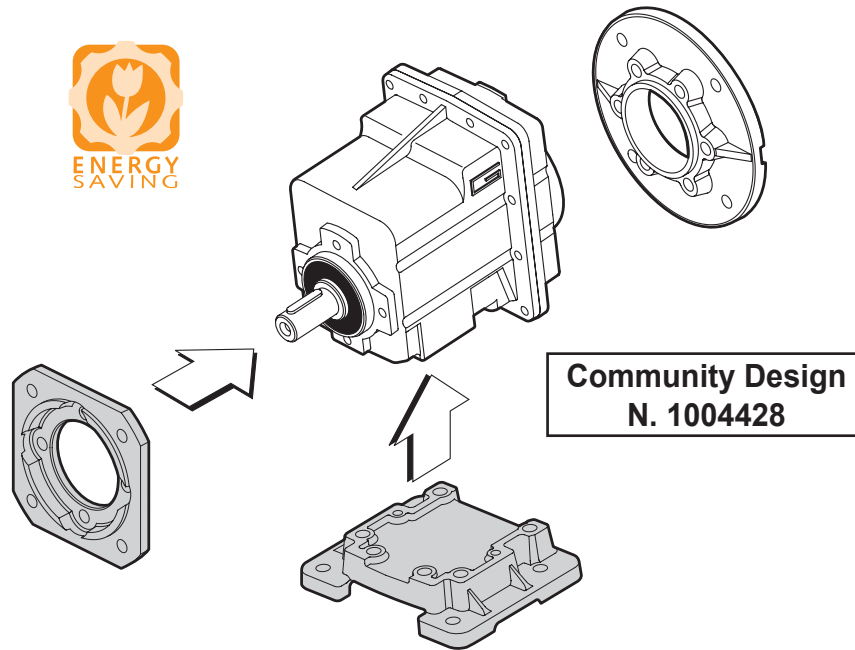

Designazione

Classification

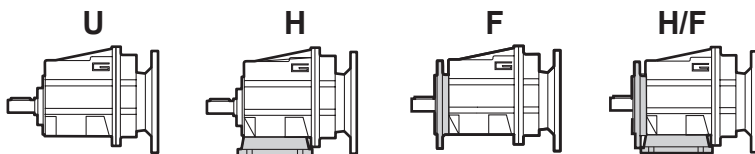

MOTORIDUTTORE / GEARMOTOR

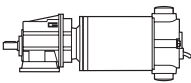
ECMG	100/002						U	8.99	D20	240
Tipo Type	Grandezza Size						Versione Version	Rapporto Ratio	Albero uscita Output shaft	Versione motore Motor version
ECMG 	070/002	100/002	180/002	250/002	350/002	600/002	U... H... F... H.../F...	vedi tabelle see tables	vedi tabelle see tables	120 240 24E
	070/012	100/012	180/012	250/012	350/012	600/012				
	070/013	100/013	180/013	250/013	350/013	600/013				
	070/022	100/022	180/022	250/022	350/022	600/022				
	070/023	100/023	180/023	250/023	350/023	600/023				
	070/033	100/033	180/033	250/033	350/032	600/032				
	070/043	100/043	180/043	250/043	350/033	600/033				
					350/042	600/042				
					350/043	600/043				

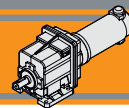

Sensi di rotazione

Direction of rotation

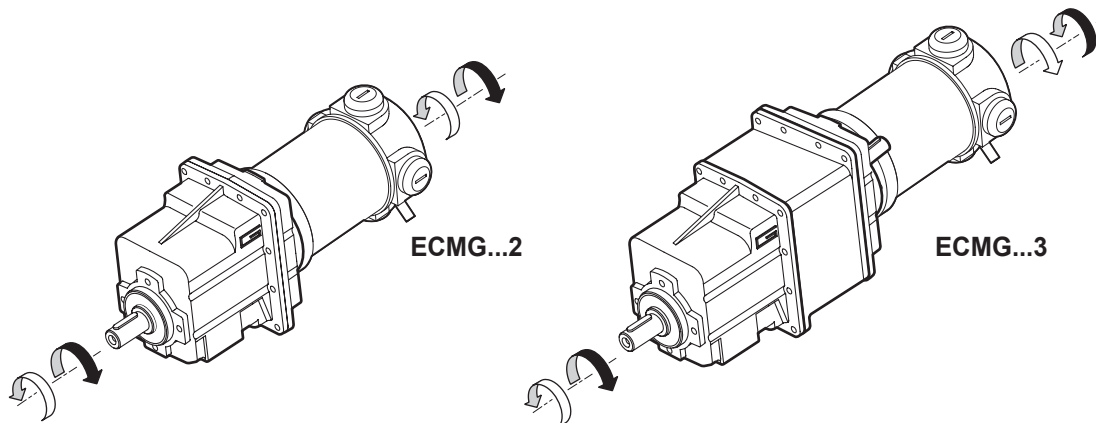

Lubrificazione

Lubrication

Tutti i riduttori sono forniti completi di lubrificante sintetico viscosità 320, pertanto possono essere installati in qualunque posizione di montaggio e non necessitano di manutenzione.

Permanent synthetic oil long-life lubrication (viscosity grade 320) makes it possible to use in all mounting positions; for this reason they can be installed in any assembly position and do not require maintenance.

ECMG

Simbologia

Symbols

n_1	[min ⁻¹]	Velocità in ingresso / <i>Input speed</i>
n_2	[min ⁻¹]	Velocità in uscita / <i>Output speed</i>
i		Rapporto di riduzione / <i>Ratio</i>
P_1	[kW]	Potenza in entrata / <i>Input power</i>
M_2	[Nm]	Coppia nominale in uscita in funzione di P_1 / <i>Output torque referred to P_1</i>
sf		Fattore di servizio / <i>Service factor</i>
R_2	[N]	Carico radiale ammissibile in uscita / <i>Permitted output radial load</i>
A_2	[N]	Carico assiale ammissibile in uscita / <i>Permitted output axial load</i>

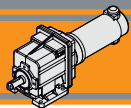

Carichi radiali

Radial loads

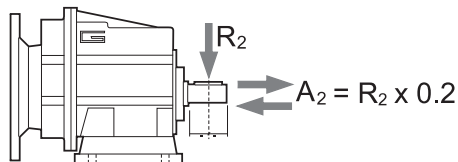

n ₂ [min ⁻¹]	R ₂ [N]				
	CMG 00	CMG 01	CMG 02	CMG 03	CMG 04
700	416	764	1529	1987	2379
600	437	805	1609	2092	2504
500	465	855	1710	2223	2661
400	501	921	1842	2395	2866
250	586	1077	2154	2801	3353
180	653	1323	2554	3321	3897
150	748	1406	2714	3529	4244
120	806	1631	3467	3801	4572
100	958	1842	3684	4507	5234
80	1032	1984	3969	5042	5991
60	1136	2184	4368	5549	6594
40	1300	2500	5000	6500	8000
10	1300	2500	5000	6500	8000

Quando il carico radiale risultante non è applicato sulla mezza-
ria dell'albero occorre calcolare quello effettivo con la seguente
formula:

When the resulting radial load is not applied on the centre line
of the shaft it is necessary to calculate the effective load with the
following formula:

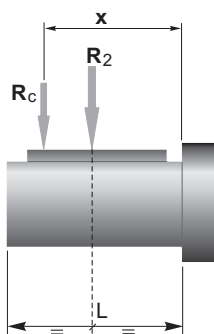

	CMG 00	CMG 01	CMG 02	CMG 03	CMG 04
a	73	104	117	132	150
b	53	84	92	102	115
R _{2MAX}	1300	2500	5000	6500	8000

$$R_c = \frac{R_2 \cdot a}{(b+x)} \leq R_{2MAX}$$

$$R \leq R_c$$

a, b = valori riportati nella tabella
a, b = values given in the table

Motori applicabili

IEC Motor adapters

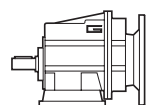
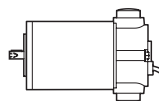

		EC						
		070.12E 070.24E	100.120 100.240 100.24E	180.120 180.240	180.24E	250.120 250.240	350.120 350.240	600.120 600.240
CMG	002	5.03 - 55.10						
	012	3.82 - 60.15						
	013	63.22 - 443.59						
	022	3.66 - 60.90						
	023	64.01 - 449.14						
	032						3.74 - 60.80	
	033	72.83 - 427.03						
	042						3.74 - 60.80	
	043	72.83 - 427.03						

5.03 - 55.10

Rapporti di riduzione i
Ratio i

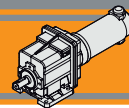

Dati tecnici per servizio S2

Technical data for S2 duty

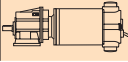
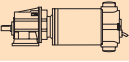
P ₁ [W]	n ₂ [min ⁻¹]	M ₂ [Nm]	sf	i		Versione motore Motor version	P ₁ [W]	n ₂ [min ⁻¹]	M ₂ [Nm]	sf	i		Versione motore Motor version					
100							140											
(3000 min ⁻¹)	596	1.5	20.2	5.03	070/002	12E/24E	(3000 min ⁻¹)	596	2.2	14.4	5.03	100/002	120/240/24E					
	492	1.9	16.6	6.10					492	2.6	11.9			6.10				
	401	2.3	13.5	7.49					401	3.2	9.7			7.49				
	334	2.7	14.2	8.99					334	3.8	10.1			8.99				
	295	3.1	12.6	10.16					295	4.3	9.0			10.16				
	249	3.7	10.6	12.07					249	5.2	7.6			12.07				
	224	4.1	13.4	13.40					224	5.7	9.6			13.40				
	198	4.6	11.9	15.14					198	6.5	8.5			15.14				
	165	5.5	9.9	18.17					165	7.8	7.1			18.17				
	139	6.6	8.3	21.58					139	9.2	6.0			21.58				
	128	7.2	7.7	23.51					128	10	5.5			23.51				
	120	7.7	7.2	25.10					120	11	5.1			25.10				
	111	8.3	6.6	27.08					111	12	4.7			27.08				
	92	9.9	5.5	32.49					92	14	4.0			32.49				
	71	13	4.3	42.04					71	18	3.1			42.04				
	67	14	4.0	44.89					67	19	2.9			44.89				
	61	15	3.7	48.86					61	21	2.6			48.86				
	54	17	3.3	55.10					54	24	2.3			55.10				
	61	15	6.3	49.00	070/012	12E/24E		85	15	6.2	35.47	100/012	120/240/24E					
	56	16	5.8	53.33					65	20	4.8			45.89				
	50	18	5.1	60.15					61	21	4.5			49.00				
	47	19	5.0	63.22	070/013	12E/24E		56	23	4.1	53.33							
	40	22	4.2	75.08					50	26	3.7	60.15						
	34	27	3.5	89.17					47	26	3.5	63.22	100/013	120/240/24E				
	27	34	2.8	113.05					40	31	3.0	75.08						
	22	40	2.3	134.27					34	37	2.5	89.17						
	17	52	1.8	173.72					27	47	2.0	113.05						
	15	60	1.6	202.16					22	56	1.7	134.27						
	11	78	1.2	261.57					17	73	1.3	173.72						
	10	91	1.0	304.00					15	85	1.1	202.16						
	7.6	118	0.8	393.33					11	110	0.9	261.57						
	6.8	133	0.7	443.59			10	127	0.7	304.00								
	22	41	3.8	135.95	070/023	12E/24E		7.6	134	0.7	393.33							
	17	53	3.0	175.89					6.8	134	0.7	443.59						
	15	61	2.5	204.69					33	38	4.1	90.29	100/023	120/240/24E				
	11	79	2.0	264.84					26	48	3.3	114.46						
	10	92	1.7	307.80					22	57	2.7	135.95						
	7.5	119	1.3	398.25					17	74	2.1	175.89						
	6.7	134	1.2	449.14					15	86	1.8	204.69						
	13	67	3.5	225.47			070/033	12E/24E		11	111	1.4			264.84			
	11	78	3.0	262.05							10	129			1.2	307.80		
	9.2	97	2.4	325.79							7.5	167			0.9	398.25		
	7.9	113	2.1	378.64					6.7	188	0.8	449.14						
	7.0	128	1.8	427.03					17	73	3.2	174.26			100/033	120/240/24E		
	9.2	97	4.0	325.79	070/043	12E/24E				13	94	2.5	225.47					
	7.9	113	3.4	378.64							11	110	2.1	262.05				
	7.0	128	3.1	427.03					9.2	136	1.7	325.79						
									7.9	159	1.5	378.64						
									7.0	179	1.3	427.03						
									11	110	3.6	262.05	100/043	120/240/24E				
									9.2	136	2.9	325.79						
							7.9	159	2.5	378.64								
							7.0	179	2.2	427.03								

NOTA
Verificare sempre che la coppia M2 utilizzata non ecceda il valore indicato nelle caselle in grigio
NOTE
Please check that the output torque M2 does not exceed the value in the grey areas

NOTA: per servizio continuo o altamente intermittente, contattare il servizio tecnico

NOTE: for continuous or highly intermittent duty, please contact our technical service

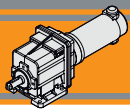

Dati tecnici per servizio S2

Technical data for S2 duty

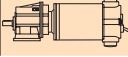
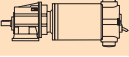
P_1 [W]	n_2 [min ⁻¹]	M_2 [Nm]	sf	i		Versione motore Motor version	P_1 [W]	n_2 [min ⁻¹]	M_2 [Nm]	sf	i		Versione motore Motor version
500							800						
(3000 min ⁻¹)	41	109	3.6	72.83	350/043	120/240	(3000 min ⁻¹)	302	24	3.9	9.93	600/022	120/240
	31	146	2.7	97.45									
	26	173	2.3	115.74									
	21	211	1.9	140.81									
	17	261	1.5	174.26									
	13	337	1.2	225.47									
	11	392	1.0	262.05									
	9.2	487	0.8	325.79									
	7.9	557	0.7	378.64									
	7.0	557	0.7	427.03									
(3000 min ⁻¹)	596	12	2.5	5.03	600/002	120/240	47	153	1.0	64.01	600/023	120/240	
	492	15	2.1	6.10			39	182	0.9	76.02			
	401	18	1.7	7.49			33	216	0.7	90.29			
	334	22	1.8	8.99			26	223	0.7	114.46			
	295	25	1.6	10.16			22	223	0.7	135.95			
	249	30	1.3	12.07			120	61	3.8	24.99			600/032
	224	33	1.7	13.40			98	75	3.1	30.57			
	198	37	1.5	15.14			88	84	2.8	34.20			
	165	44	1.2	18.17			78	94	2.5	38.63			
	139	53	1.0	21.58			68	108	2.2	44.18			
	128	57	1.0	23.51			58	125	1.9	51.30			
	120	61	0.9	25.10			49	149	1.6	60.80	600/033	120/240	
	111	66	0.8	27.08			41	174	1.3	72.83			
	92	79	0.7	32.49			31	233	1.0	97.45			
	71	79	0.7	42.04			26	277	0.8	115.74			
	67	79	0.7	44.89			21	334	0.7	140.81			
	785	9	5.0	3.82			17	334	0.7	174.26			600/042
	648	11	4.2	4.63			78	94	4.1	38.63			
	527	14	3.4	5.69			68	108	3.6	44.18			
	389	19	3.3	7.72			58	125	3.1	51.30			
	327	22	2.8	9.17			49	149	2.5	60.80			
	306	24	2.6	9.81			41	174	2.2	72.83	600/043	120/240	
	261	28	2.8	11.5	31	233	1.7	97.45					
	252	29	2.7	11.9	26	277	1.4	115.74					
	217	34	2.8	13.8	21	337	1.2	140.81					
	205	36	2.6	14.62	17	417	0.9	174.26					
	168	44	2.2	17.86	13	540	0.7	225.47					
	157	47	2.0	19.07	11	557	0.7	262.05	600/013	120/240			
	151	48	1.9	19.83	9	557	0.7	325.79					
	127	58	1.6	23.56									
	101	72	1.3	29.56									
	85	87	1.1	35.47									
	65	112	0.8	45.89									
	61	120	0.8	49.00									
	56	130	0.7	53.33									
	47	134	0.7	63.22									
	40	134	0.7	75.08									

NOTA
Verificare sempre che la coppia M_2 utilizzata non ecceda il valore indicato nelle caselle in grigio
NOTE
Please check that the output torque M_2 does not exceed the value in the grey areas

NOTA: per servizio continuo o altamente intermittente, contattare il servizio tecnico
NOTE: for continuous or highly intermittent duty, please contact our technical service

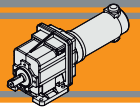

Dimensioni

Dimensions

ECMG..U

ECMG070/002 U

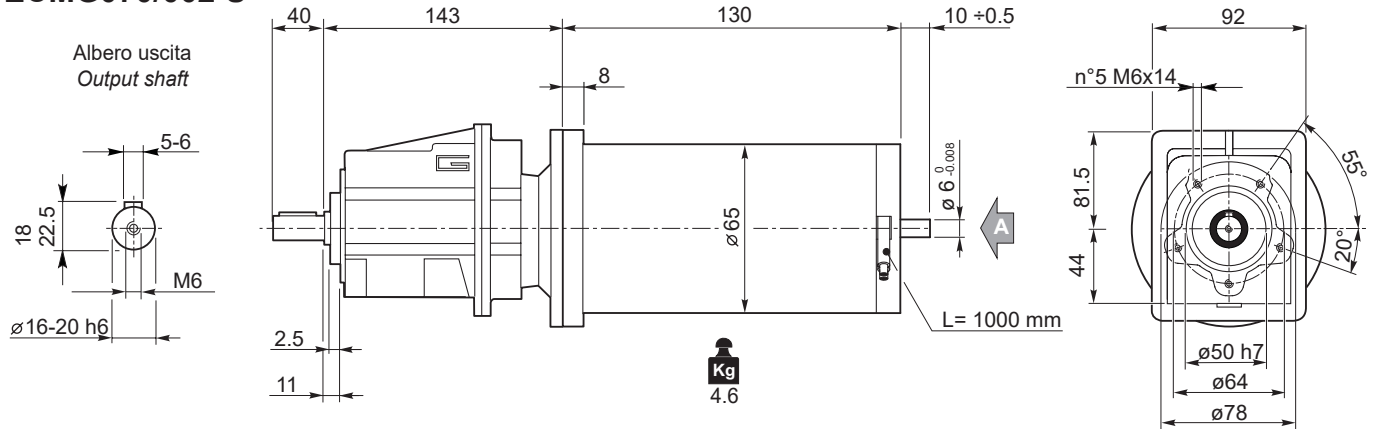

ECMG070/012 U

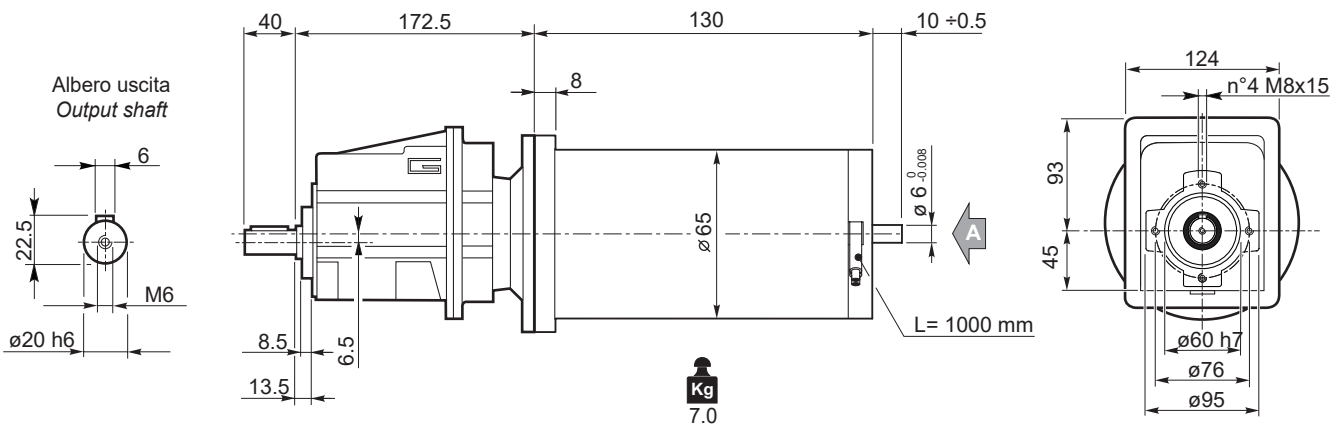

ECMG070/013 U

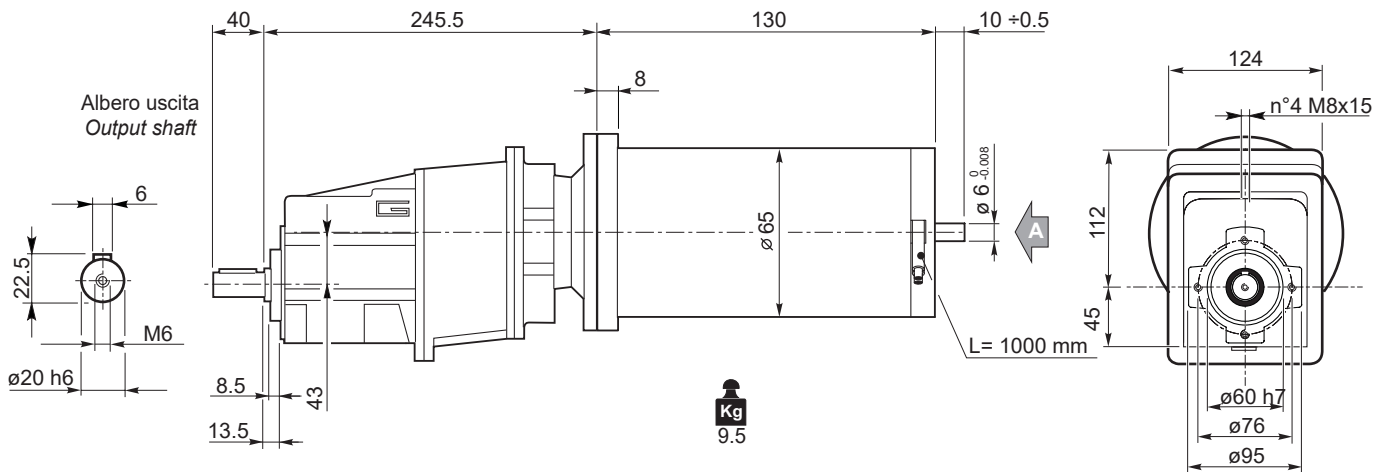

ECMG

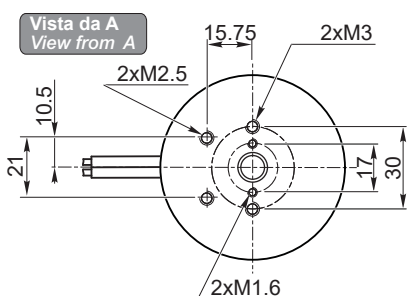

Freno / Brake



Encoder



Motori / Motors IP66



ECMG...H



ECMG...F



ECMG...H/F



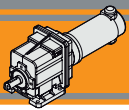

Dimensioni

Dimensions

ECMG..U

ECMG070/022 U

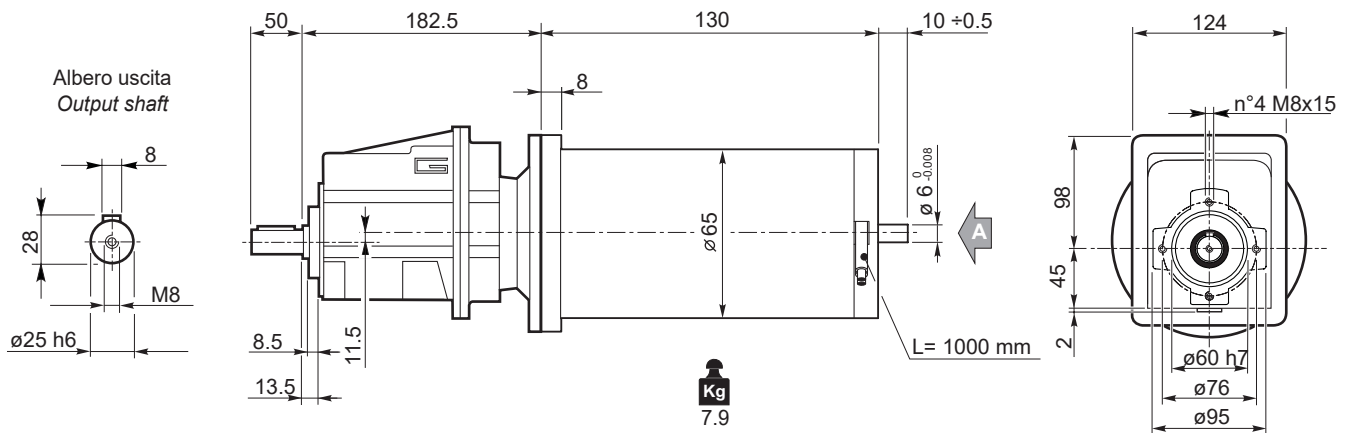

ECMG070/023 U

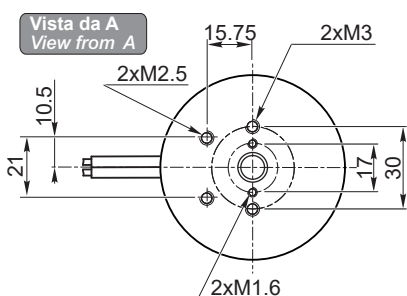
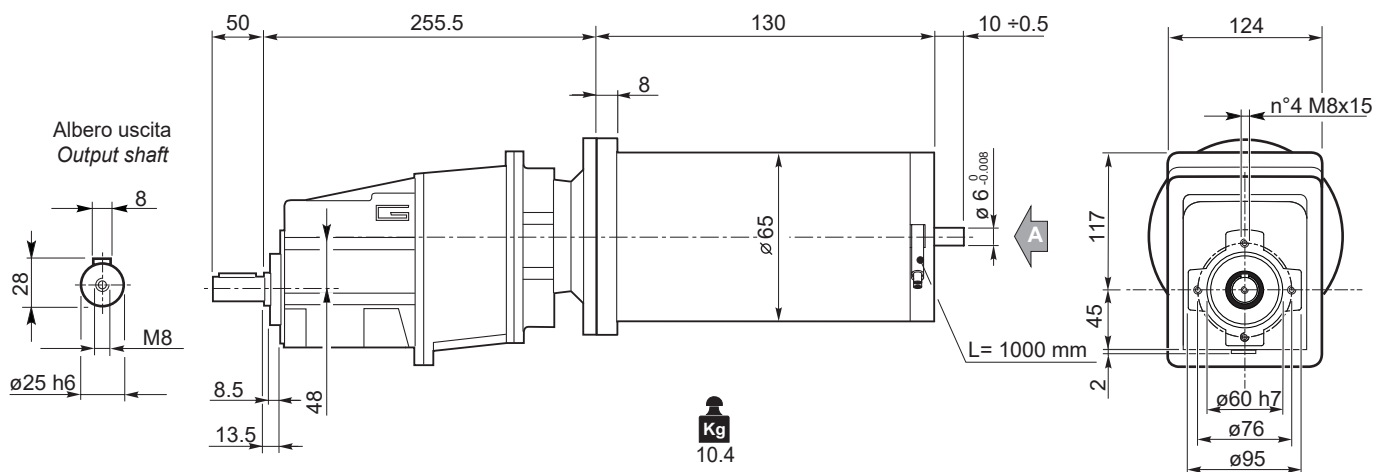

Freno / Brake



H23

ECMG...H



L30

Encoder



H24

ECMG...F



L31

Motori / Motors IP66



I2

ECMG...H/F



L32

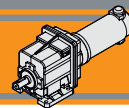

Dimensioni

Dimensions

ECMG..U

ECMG070/033 U

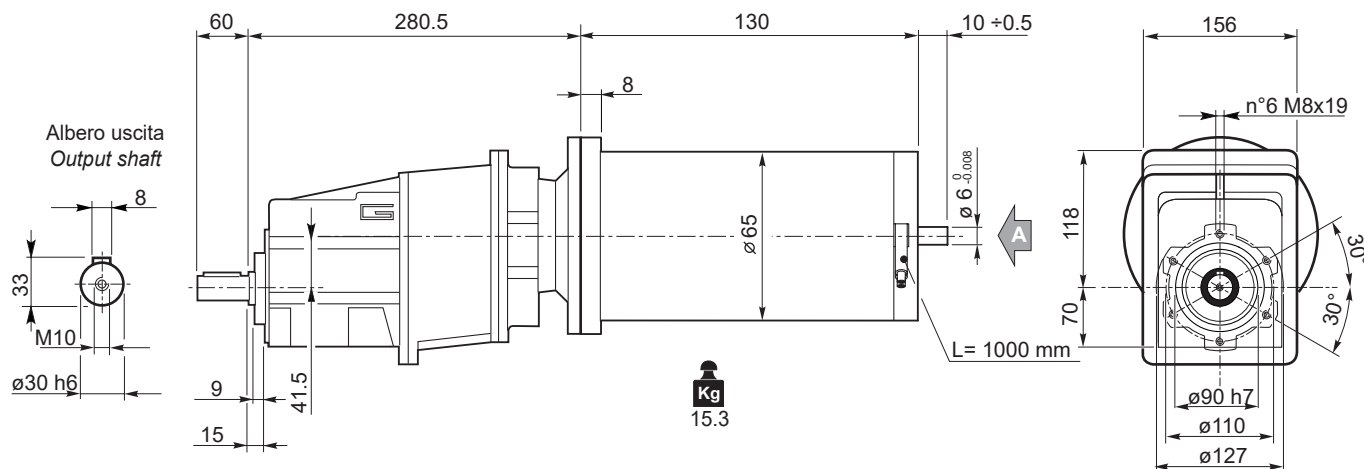

ECMG070/043 U

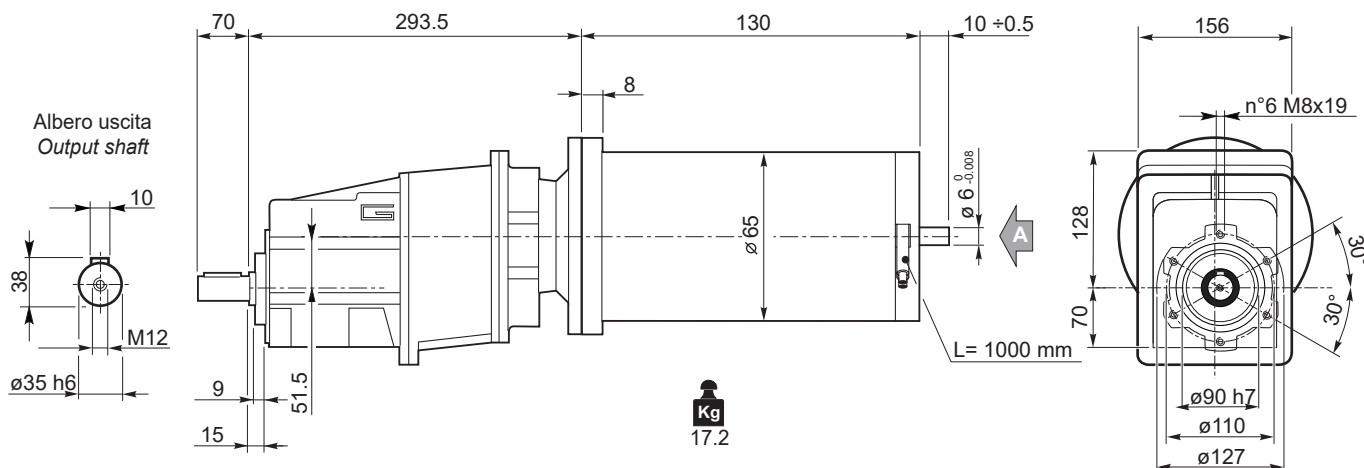

ECMG

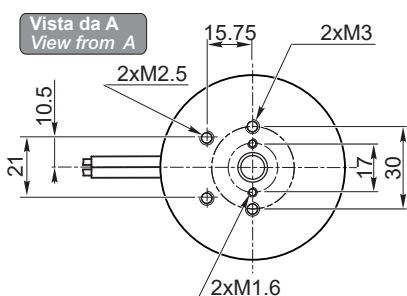

Freno / Brake



ECMG...H



Encoder



ECMG...F



Motori / Motors IP66



ECMG...H/F



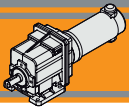

Dimensioni

Dimensions

ECMG..U

ECMG100/002 U

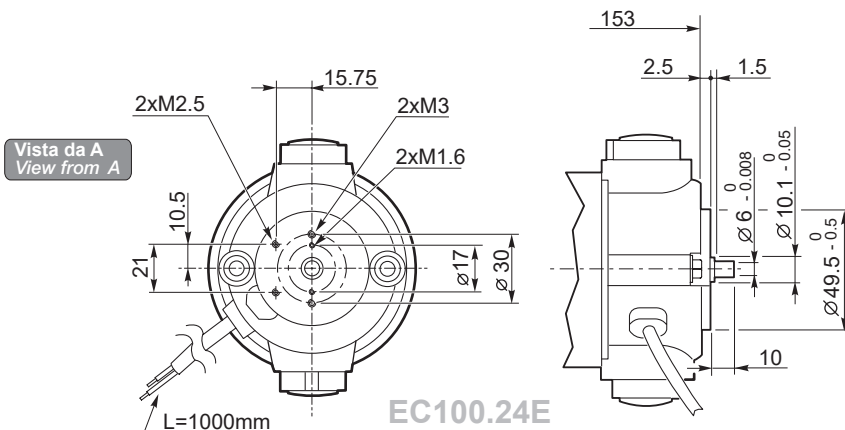
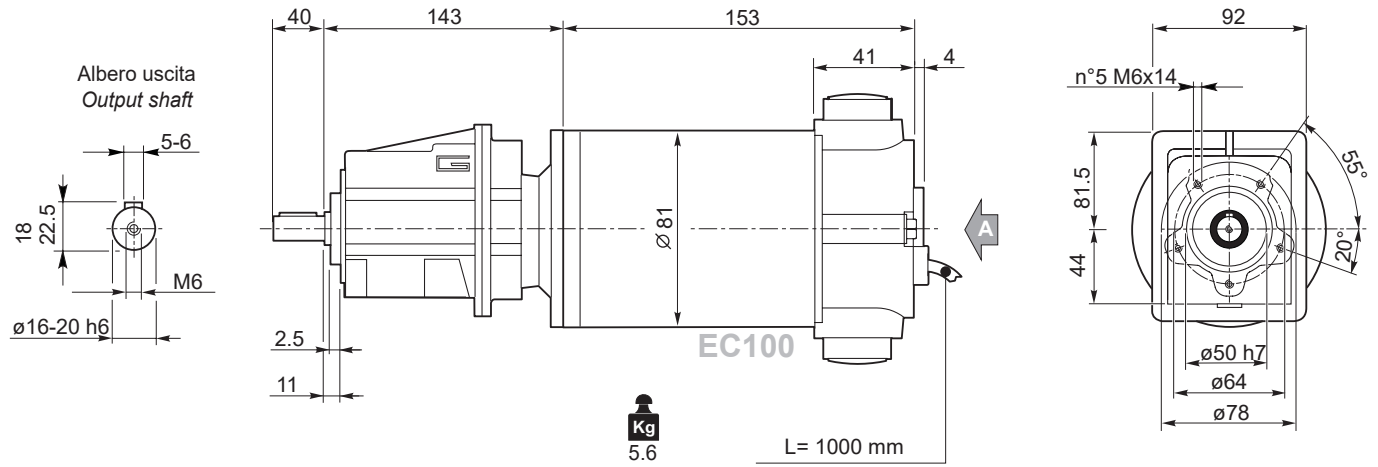

Freno / Brake → **H23**

Encoder → **H24**

Motori / Motors IP66 → **I4**

ECMG...H → **L30**

ECMG...F → **L31**

ECMG...H/F → **L32**

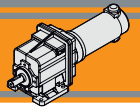

Dimensioni

Dimensions

ECMG..U

ECMG100/012 U

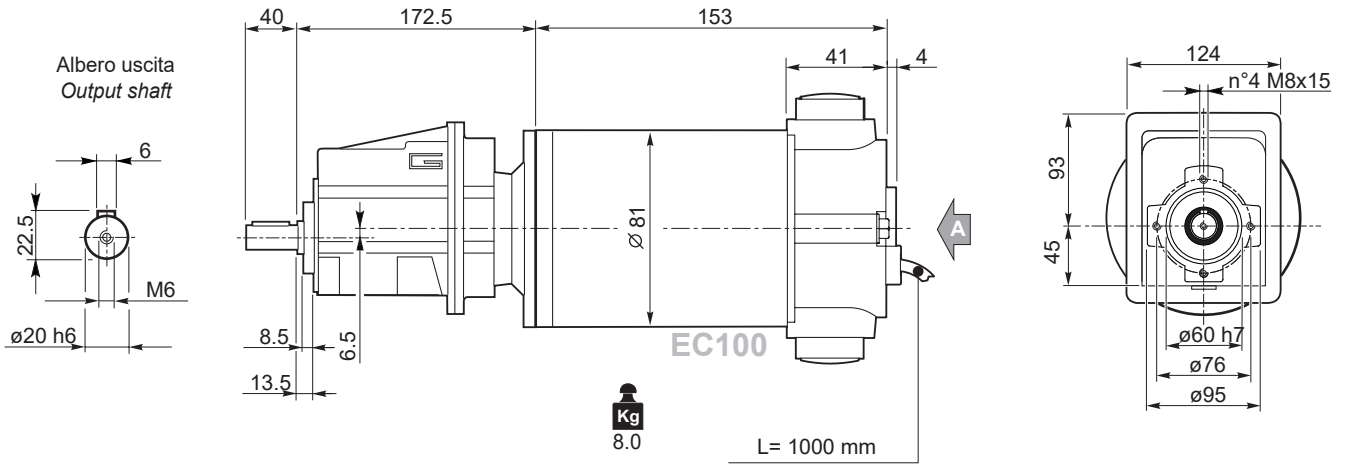

ECMG100/013 U

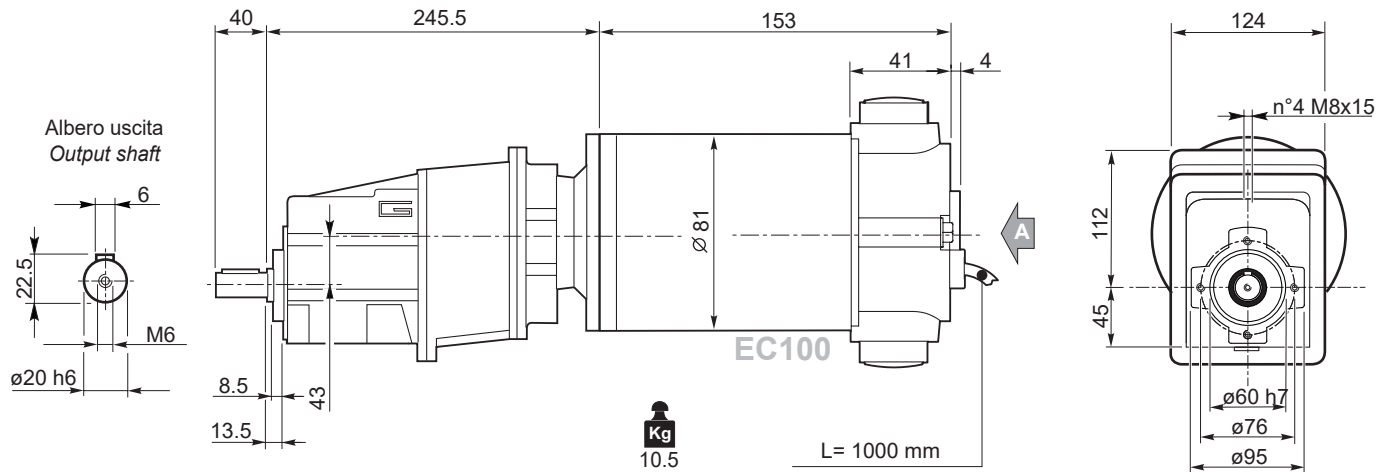

ECMG

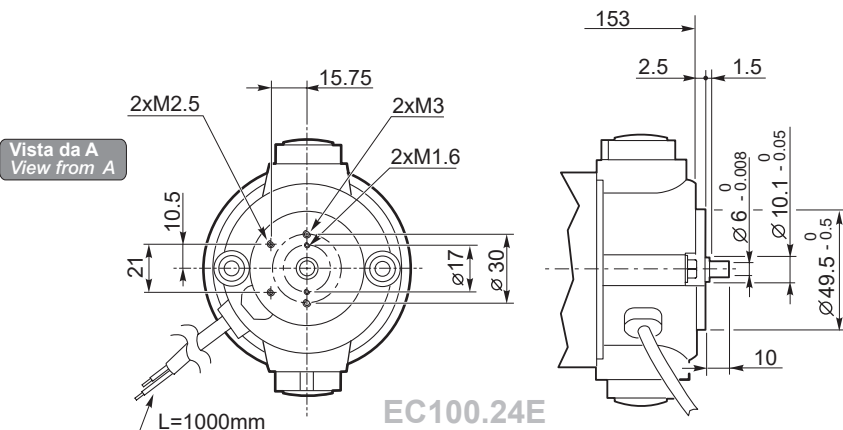

Freno / Brake → H23

Encoder → H24

Motori / Motors IP66 → I4

ECMG...H → L30

ECMG...F → L31

ECMG...H/F → L32

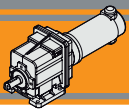

Dimensioni

ECMG..U

ECMG100/022 U

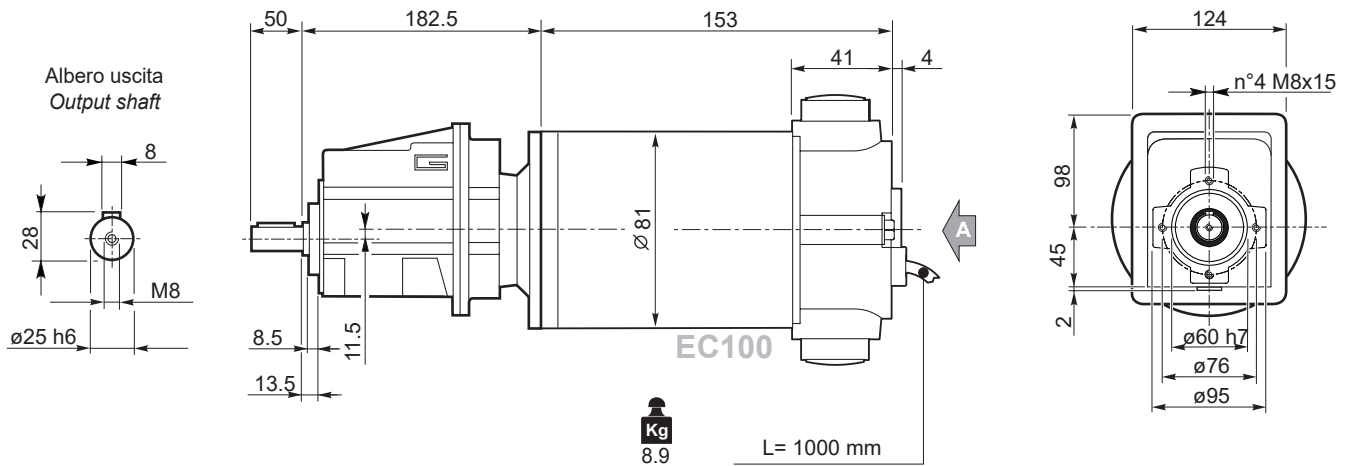

ECMG100/023 U

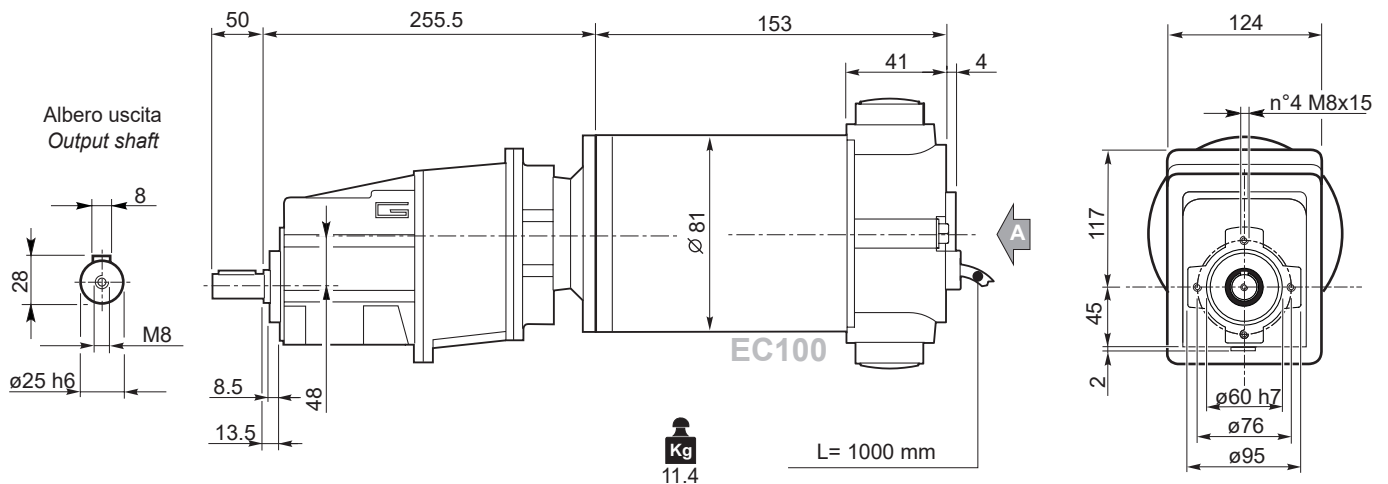

Freno / Brake → H23

Encoder → H24

Motori / Motors IP66 → I4

ECMG...H → L30

ECMG...F → L31

ECMG...H/F → L32

Vista da A
View from A

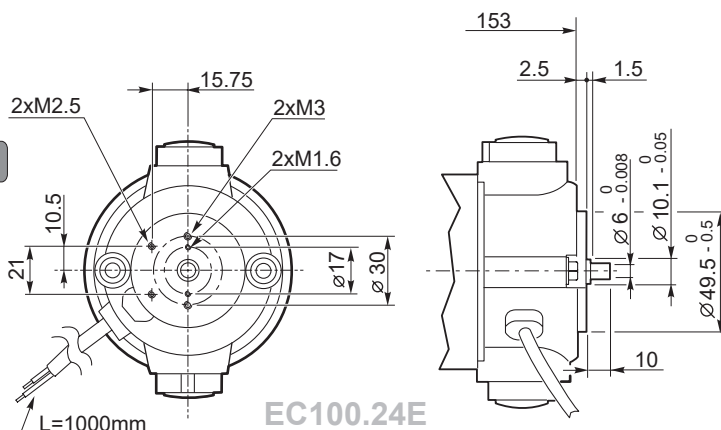

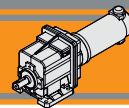

Dimensioni

ECMG..U

ECMG100/033 U

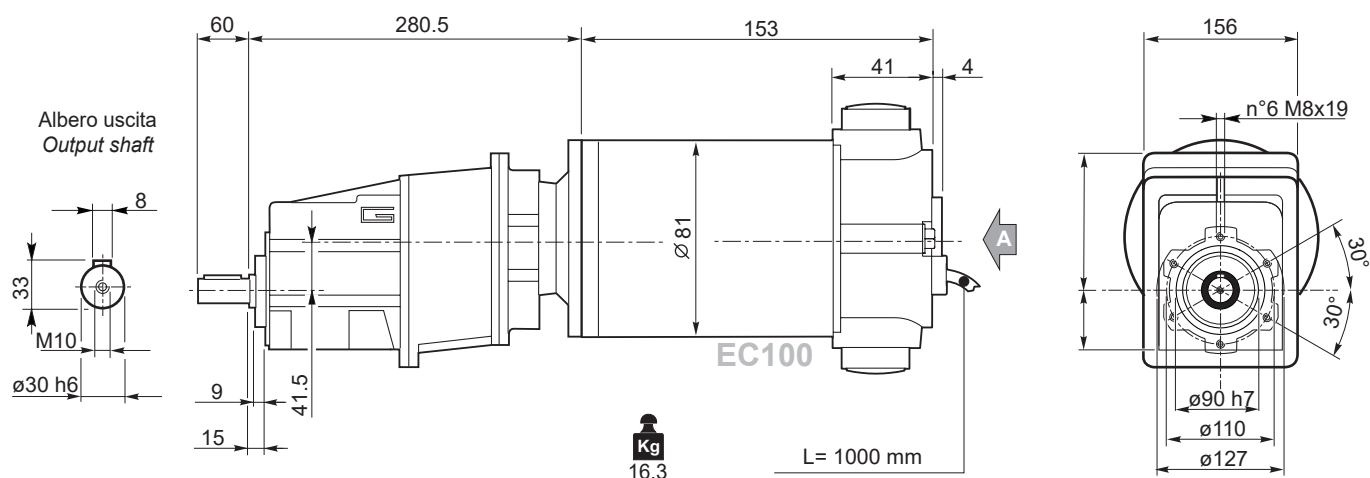

ECMG100/043 U

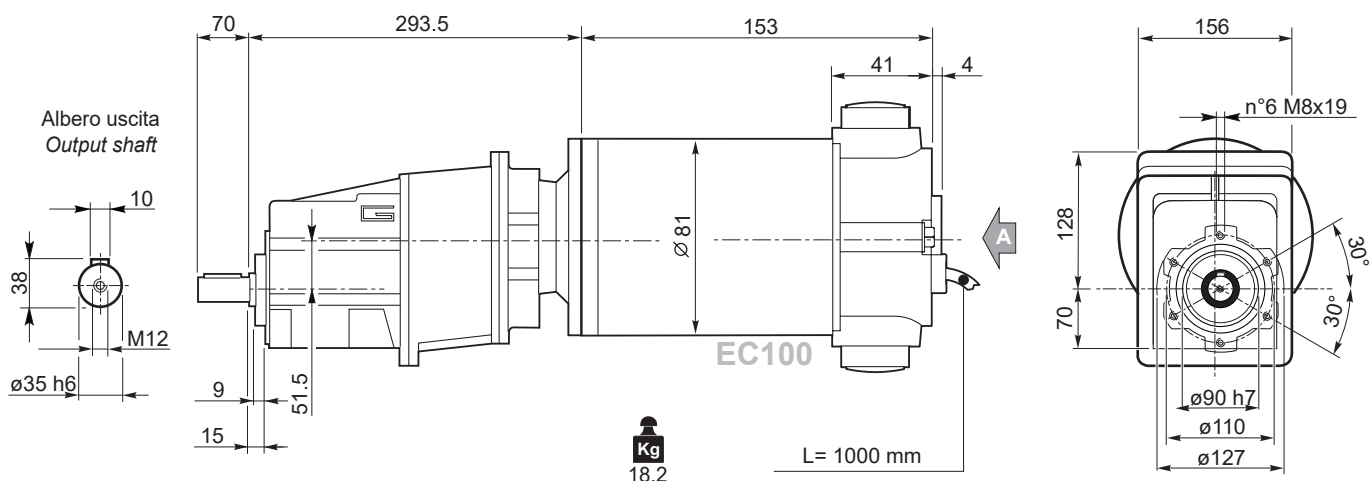

ECMG

Freno / Brake → H23

Encoder → H24

Motori / Motors IP66 → I4

ECMG...H → L30

ECMG...F → L31

ECMG...H/F → L32

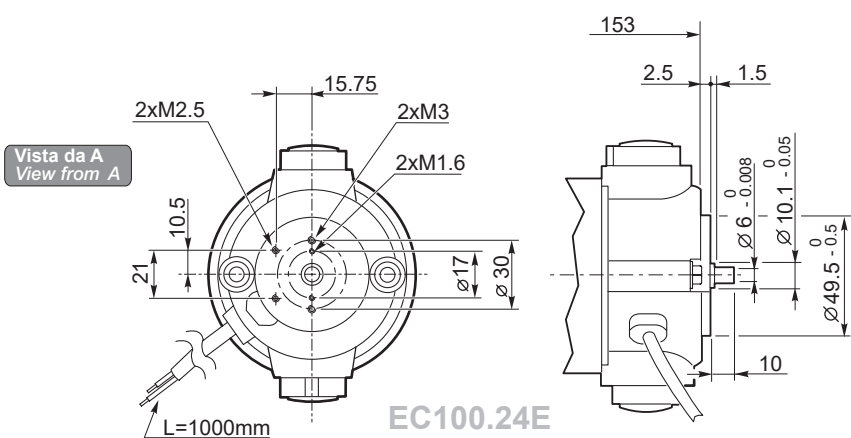

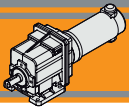

Dimensioni

Dimensions

ECMG..U

ECMG180/002 U

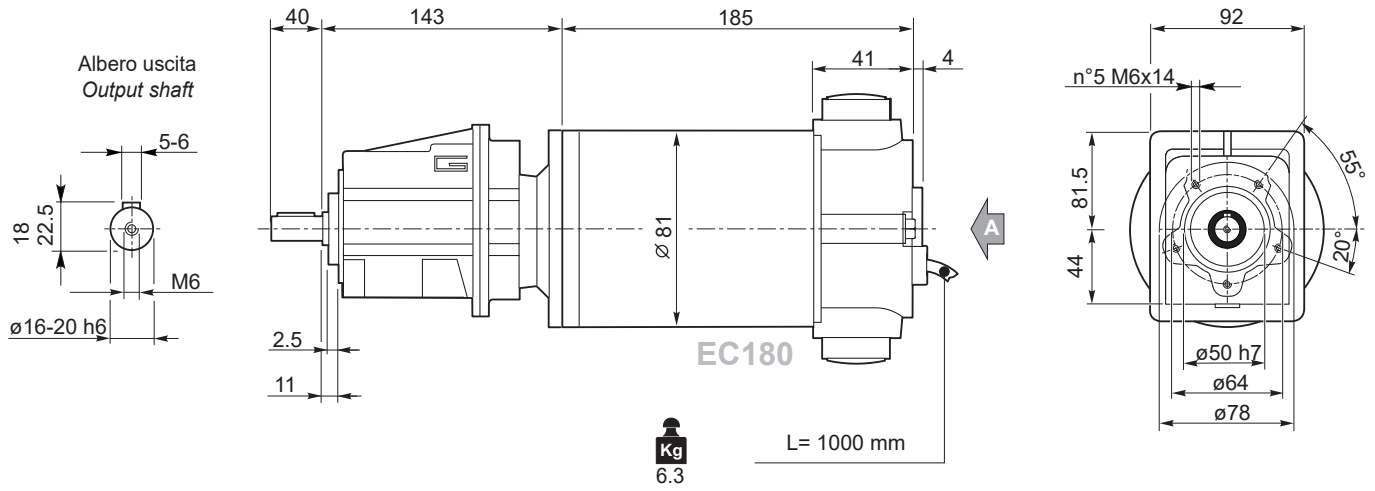

Vista da A
View from A

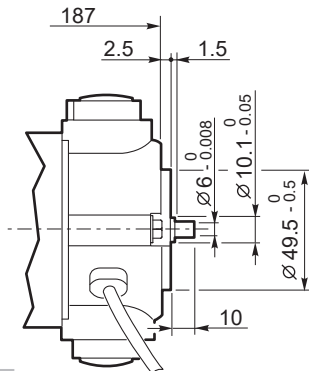
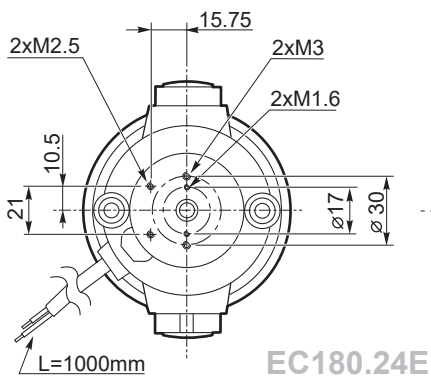

Freno / Brake → **H23**

Encoder → **H24**

Motori / Motors IP66 → **I6**

ECMG...H → **L30**

ECMG...F → **L31**

ECMG...H/F → **L32**

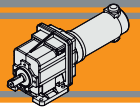

Dimensioni

Dimensions

ECMG..U

ECMG180/012 U

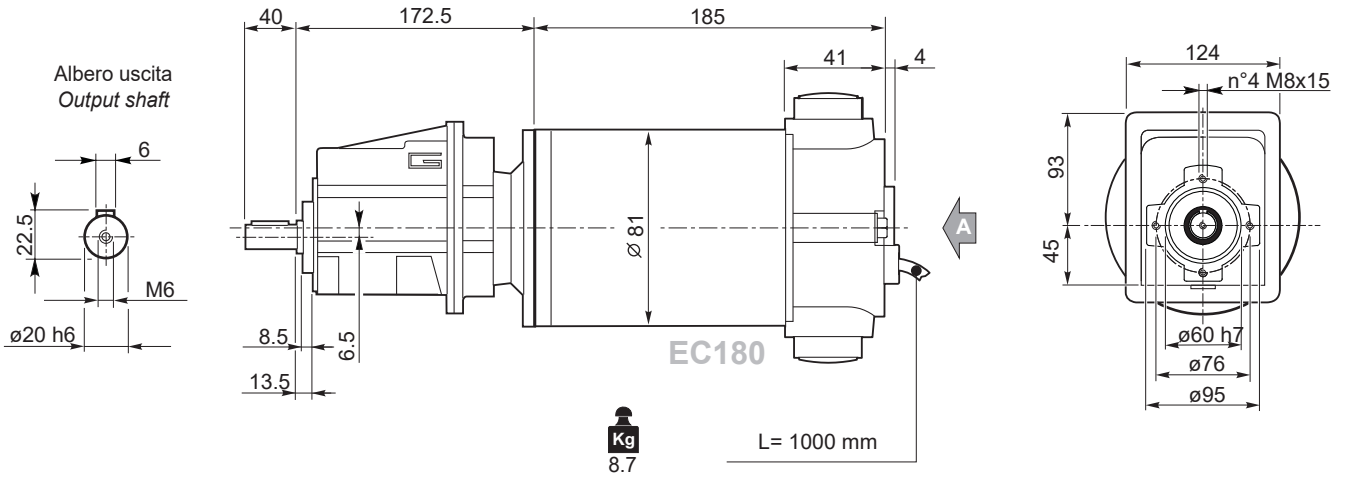

ECMG180/013 U

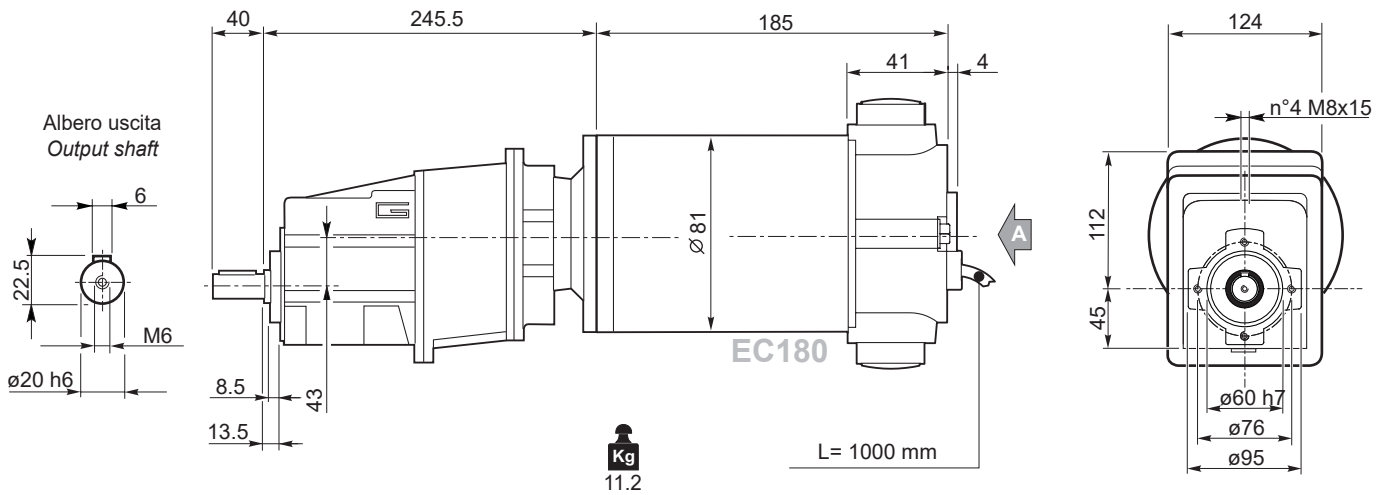

ECMG

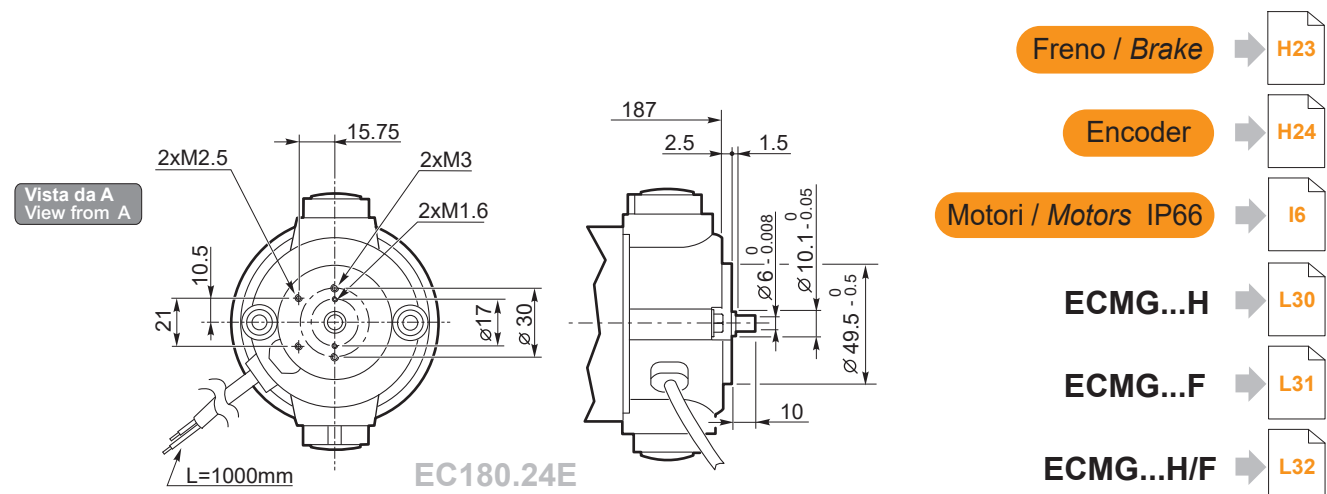

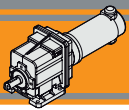

Dimensioni

Dimensions

ECMG..U

ECMG180/022 U

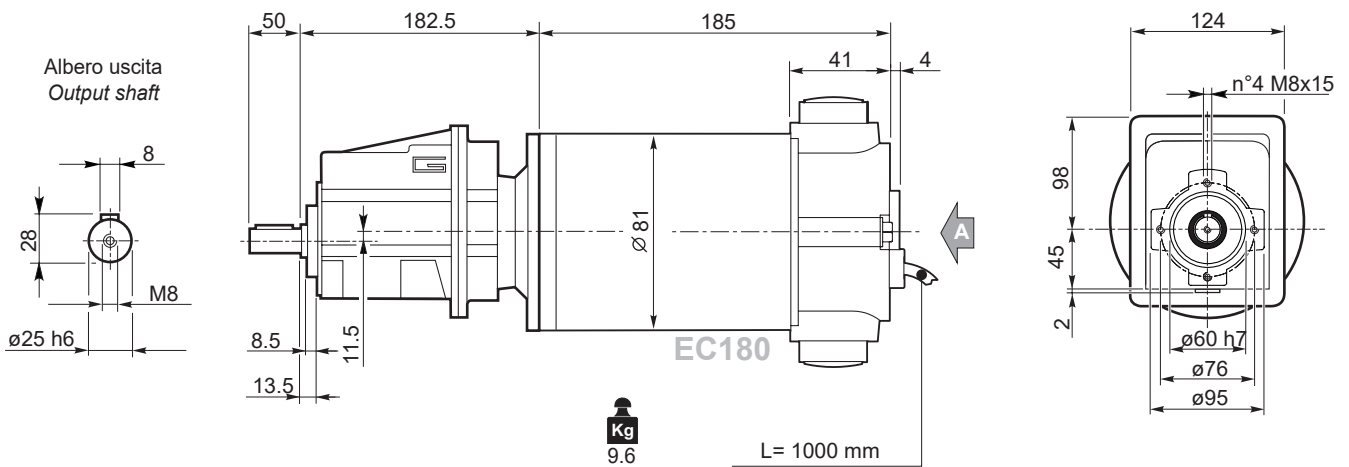

ECMG180/023 U

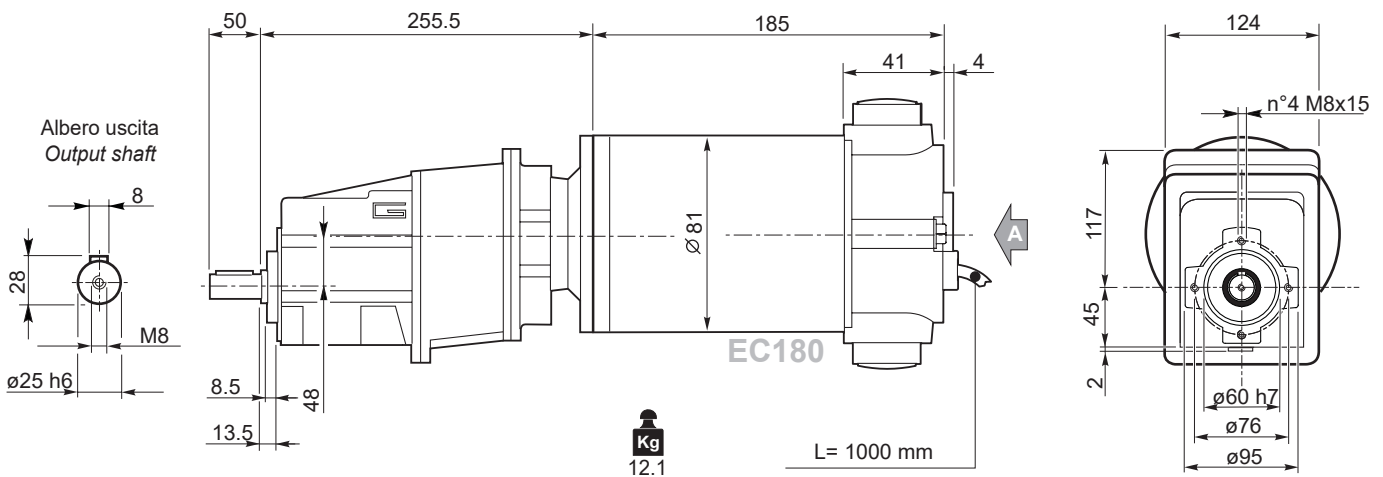

Freno / Brake → H23

Encoder → H24

Motori / Motors IP66 → I6

ECMG...H → L30

ECMG...F → L31

ECMG...H/F → L32

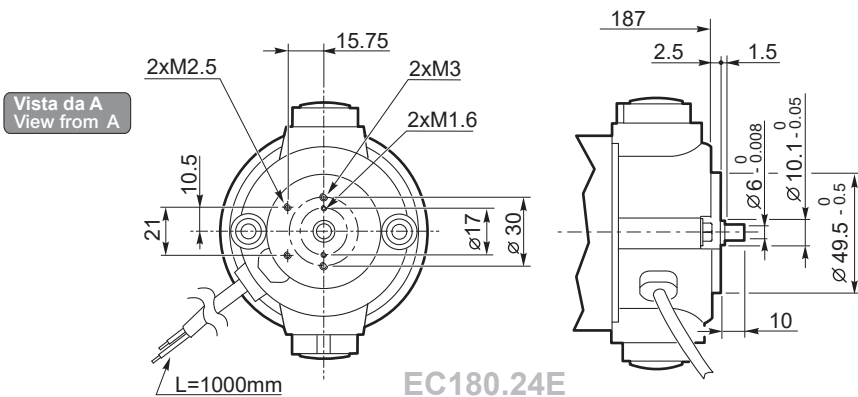

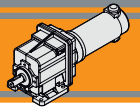

Dimensioni

Dimensions

ECMG..U

ECMG180/033 U

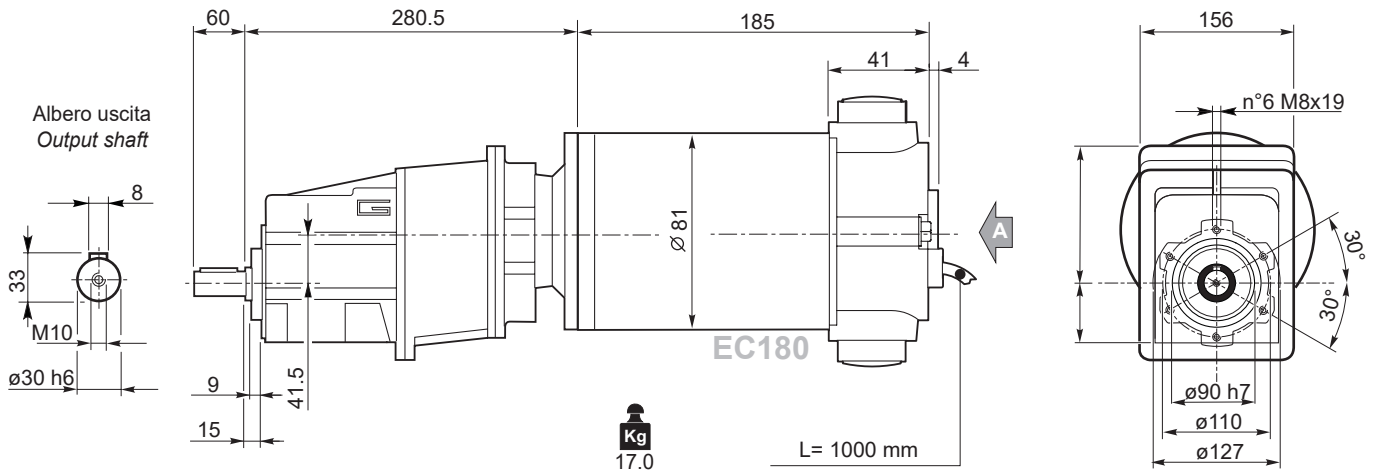

ECMG180/043 U

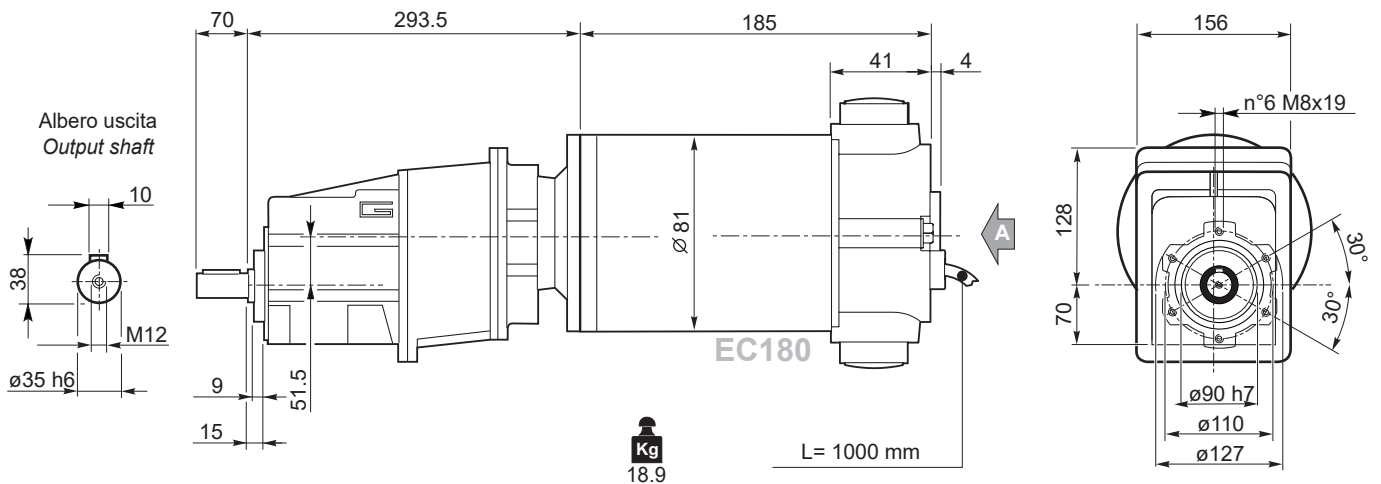

ECMG

Vista da A
View from A

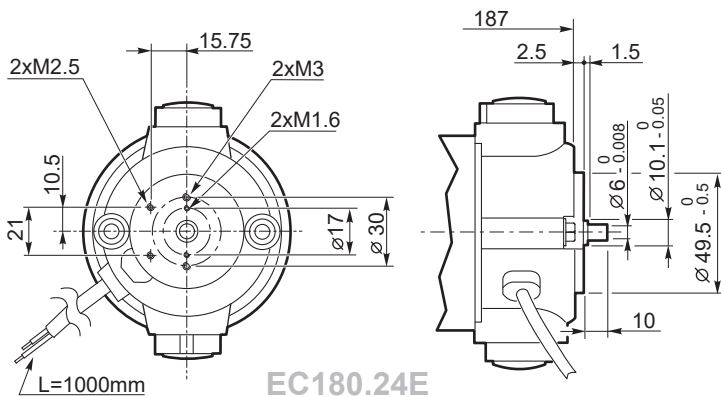

Freno / Brake

H23

Encoder

H24

Motori / Motors IP66

I6

ECMG...H

L30

ECMG...F

L31

ECMG...H/F

L32

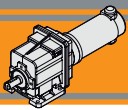

Dimensioni

Dimensions

ECMG..U

ECMG250/002 U

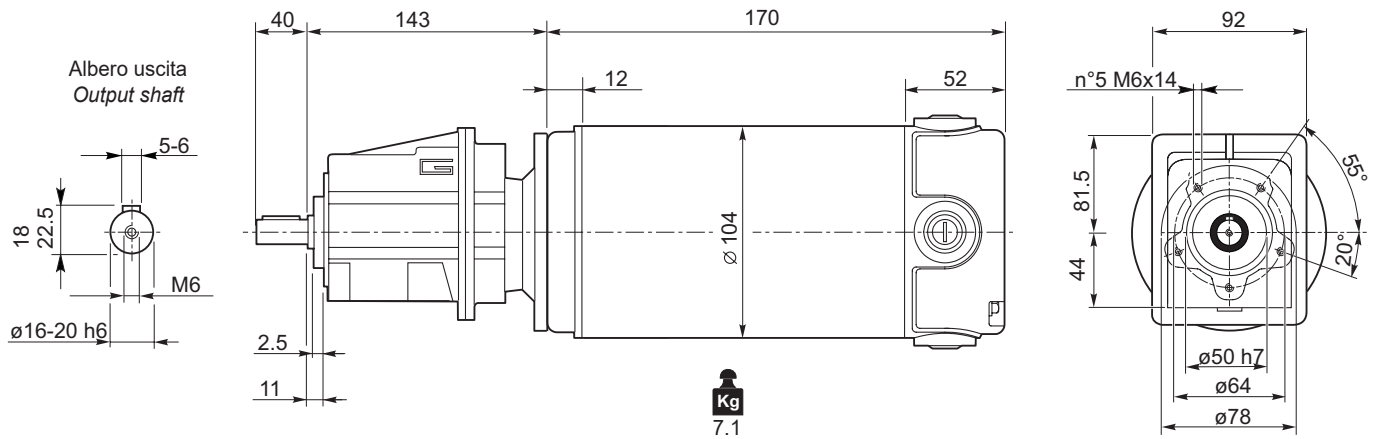

ECMG250/012 U

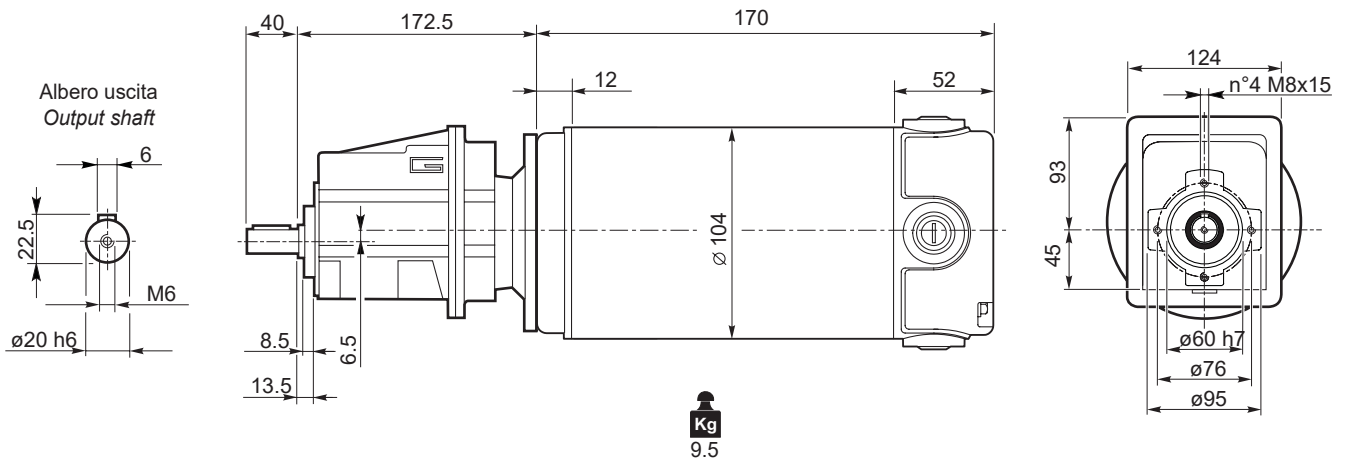

ECMG250/013 U

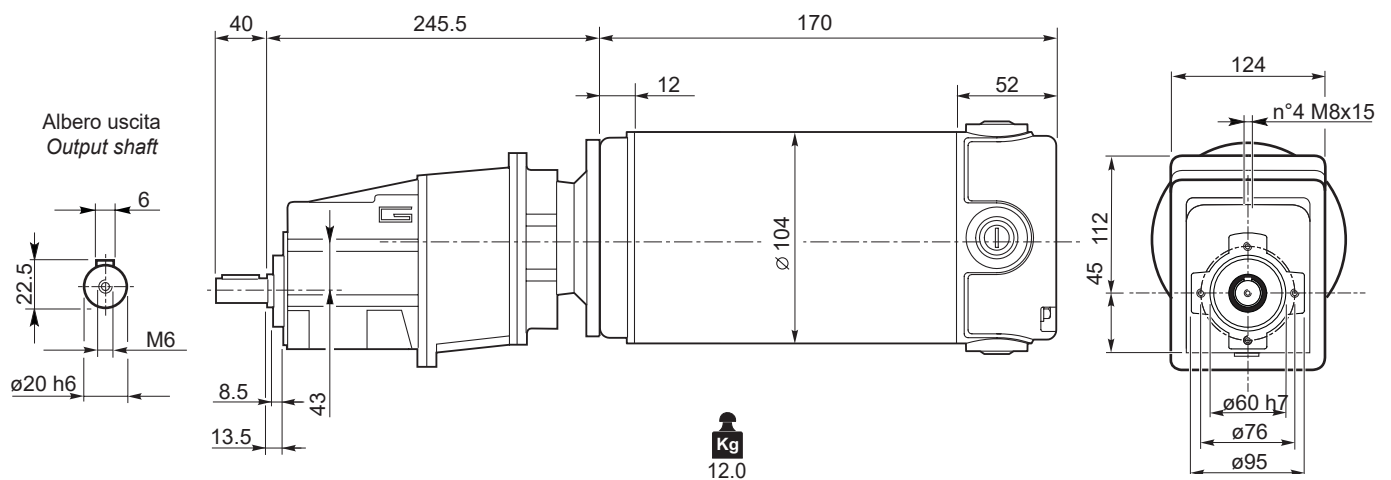

Motori / Motors IP66



ECMG...H



ECMG...F



ECMG...H/F



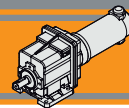

Dimensioni

Dimensions

ECMG..U

ECMG250/022 U

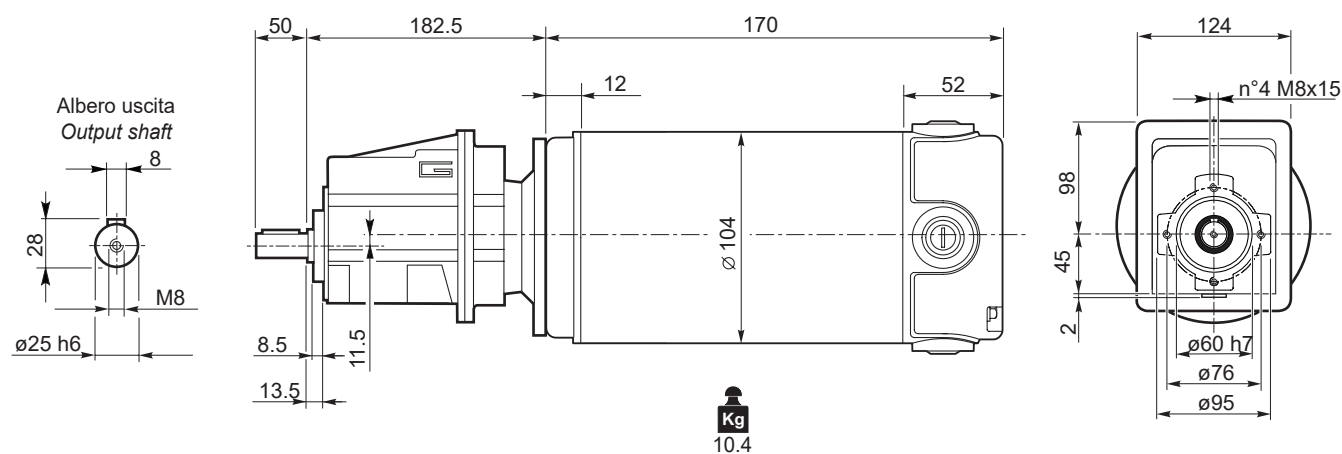

ECMG250/023 U

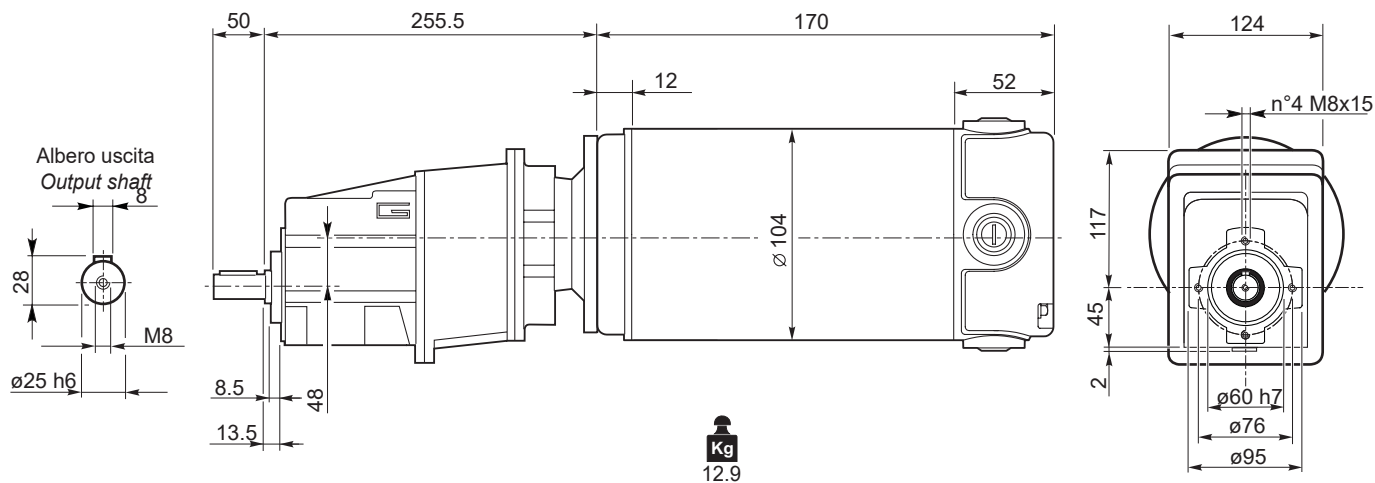

ECMG

Motori / Motors IP66



ECMG...H



ECMG...F



ECMG...H/F



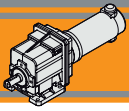

Dimensioni

Dimensions

ECMG..U

ECMG250/033 U

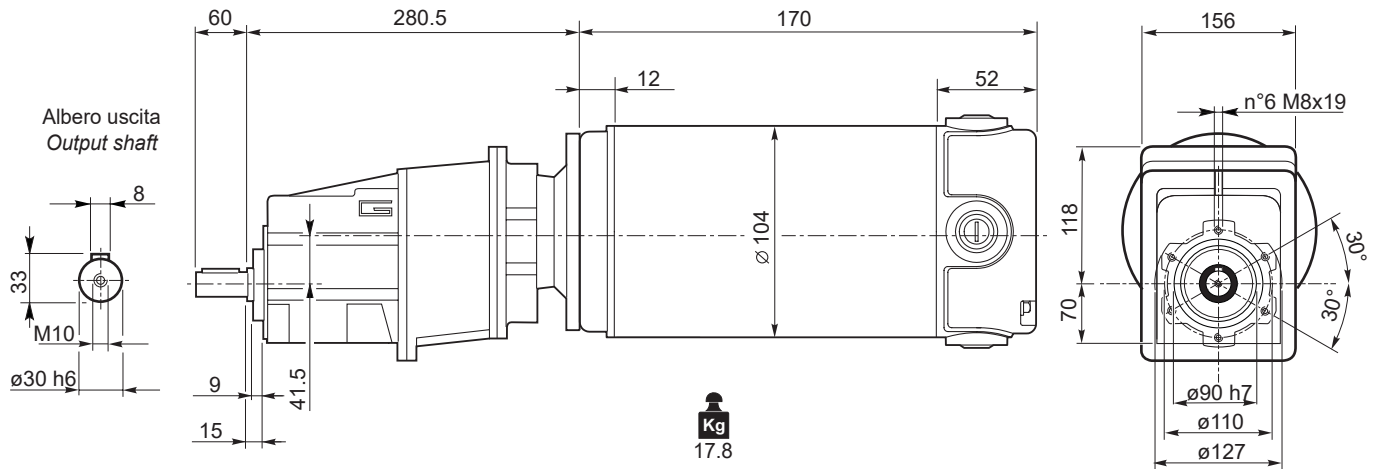

ECMG250/043 U

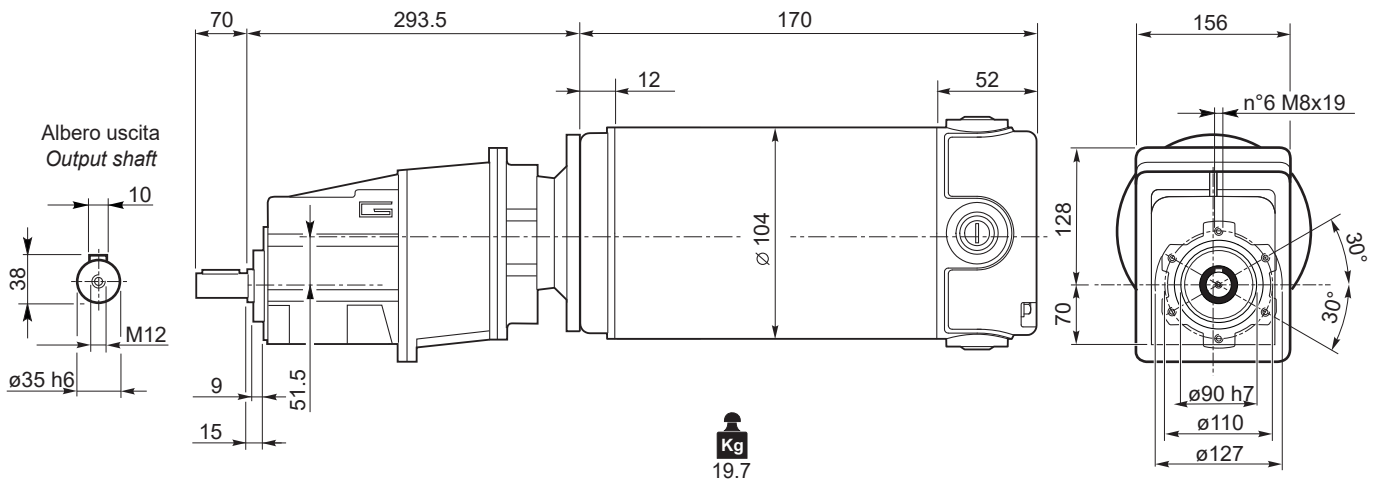

Motori / Motors IP66



ECMG...H



ECMG...F



ECMG...H/F



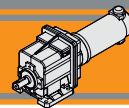

Dimensioni

Dimensions

ECMG..U

ECMG350/002 U

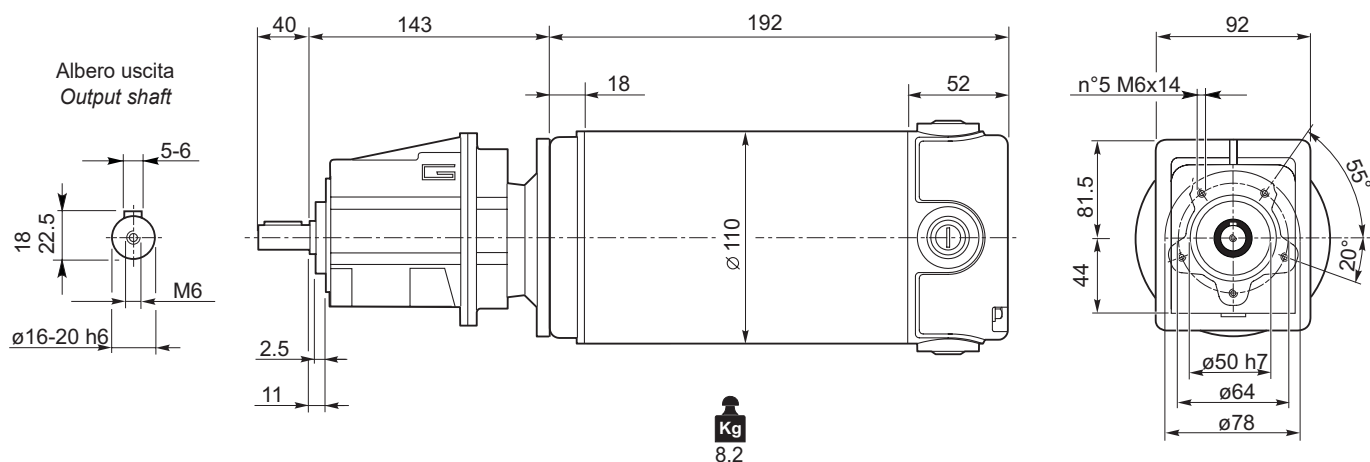

ECMG350/012 U

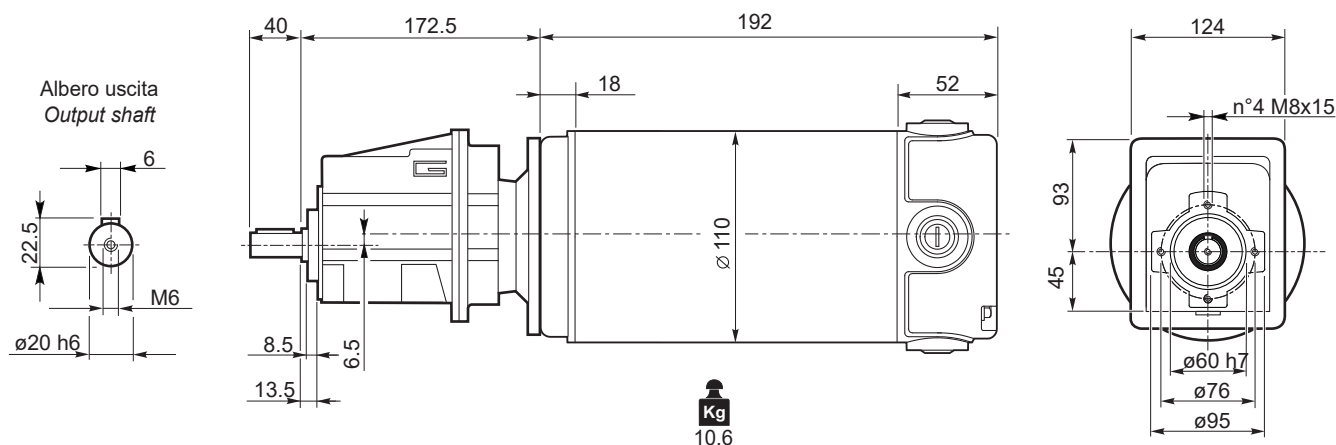

ECMG350/013 U

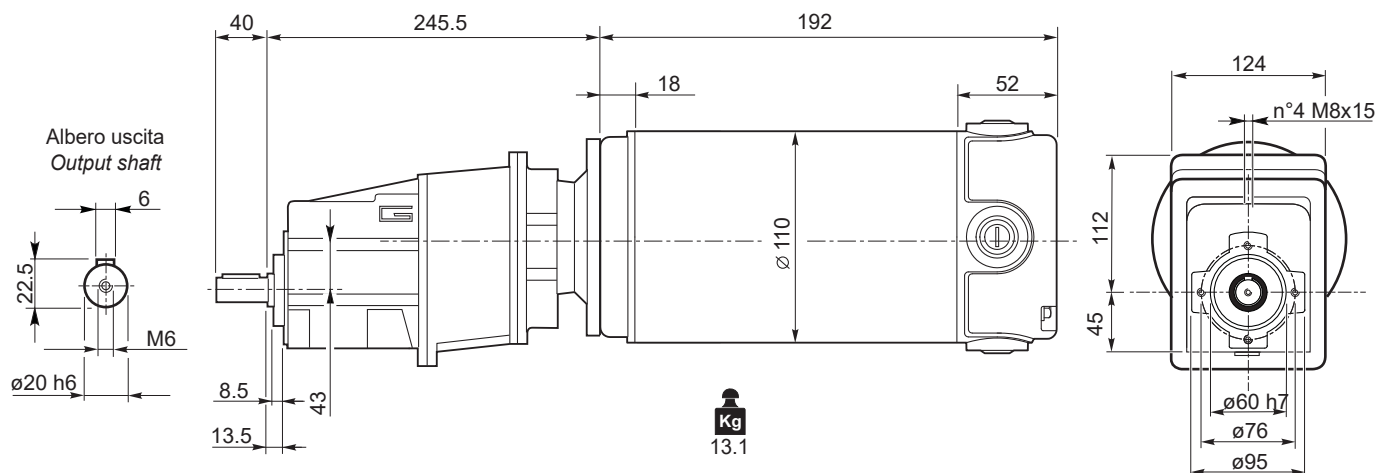

Freno / Brake



H23

Motori / Motors IP66



I10

ECMG...H



L30

ECMG...F



L31

ECMG...H/F



L32

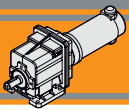

Dimensioni

Dimensions

ECMG..U

ECMG350/022 U

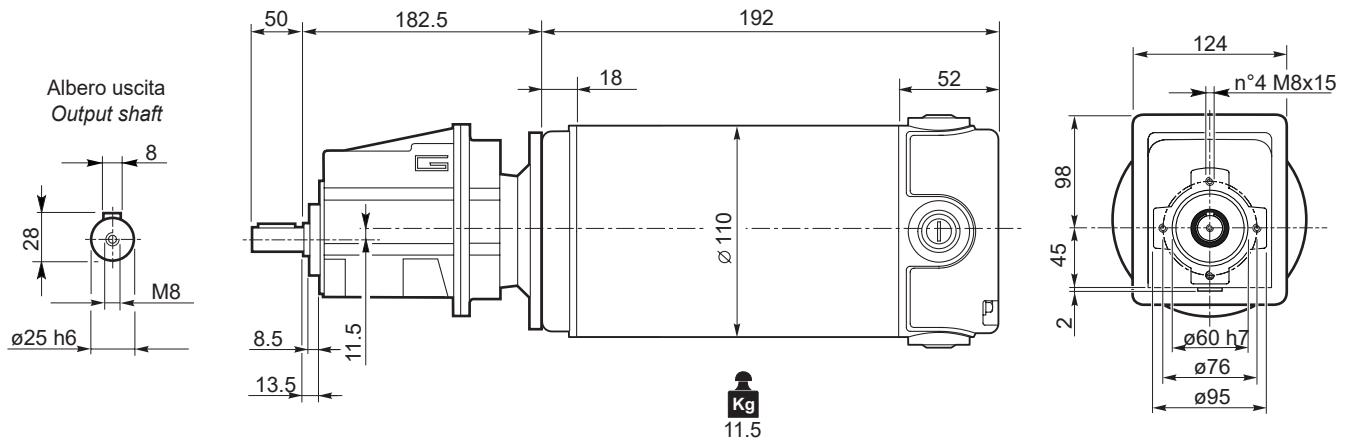

ECMG350/023 U

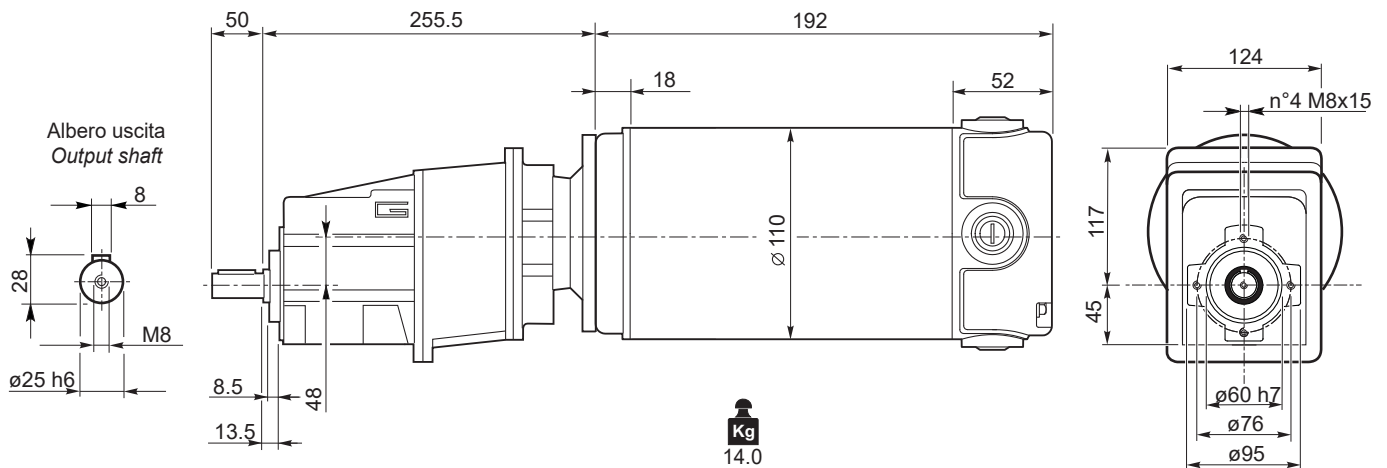

ECMG350/032 U

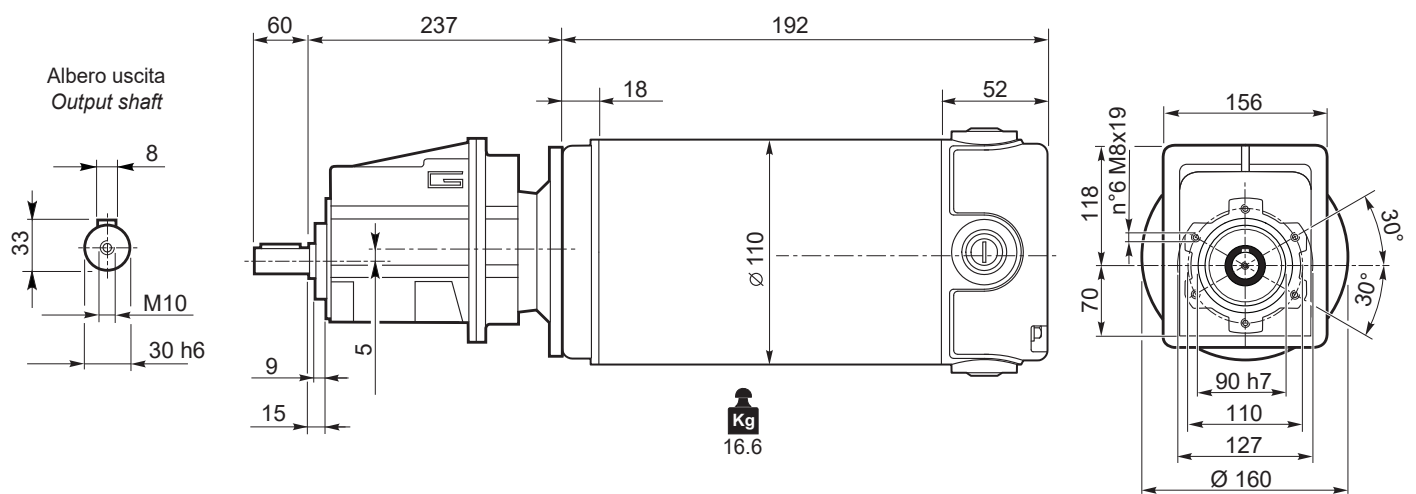

Freno / Brake



H23

ECMG...H



L30

ECMG...F



L31

ECMG...H/F



L32

Motori / Motors IP66



I10

Nota: Motore IP66 non disponibile per ECMG350/032
Note: IP66 motor not available for ECMG350/032

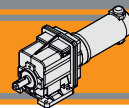

Dimensioni

Dimensions

ECMG..U

ECMG350/033 U

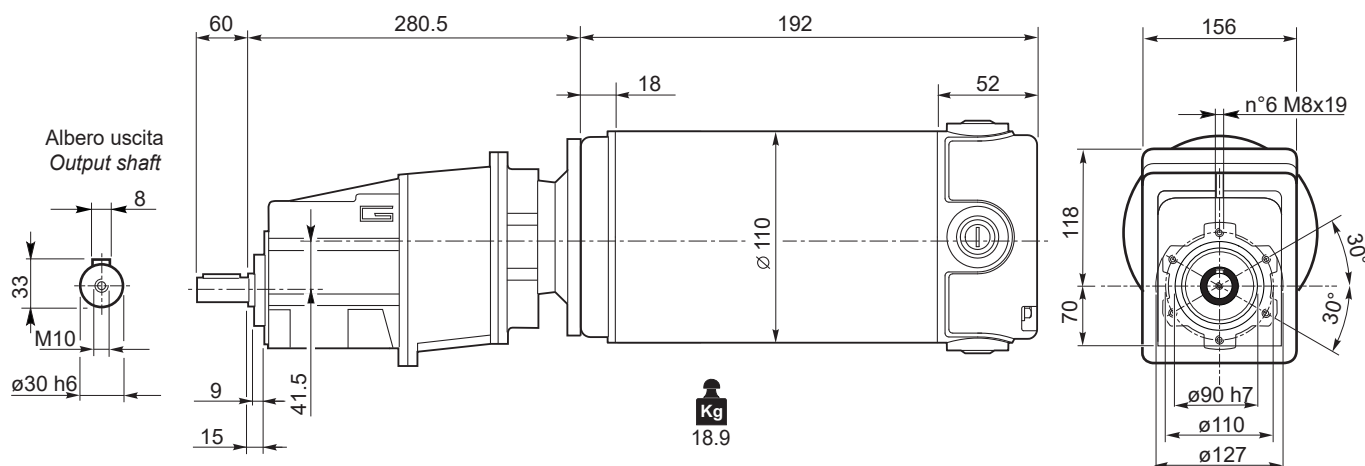

ECMG350/042 U

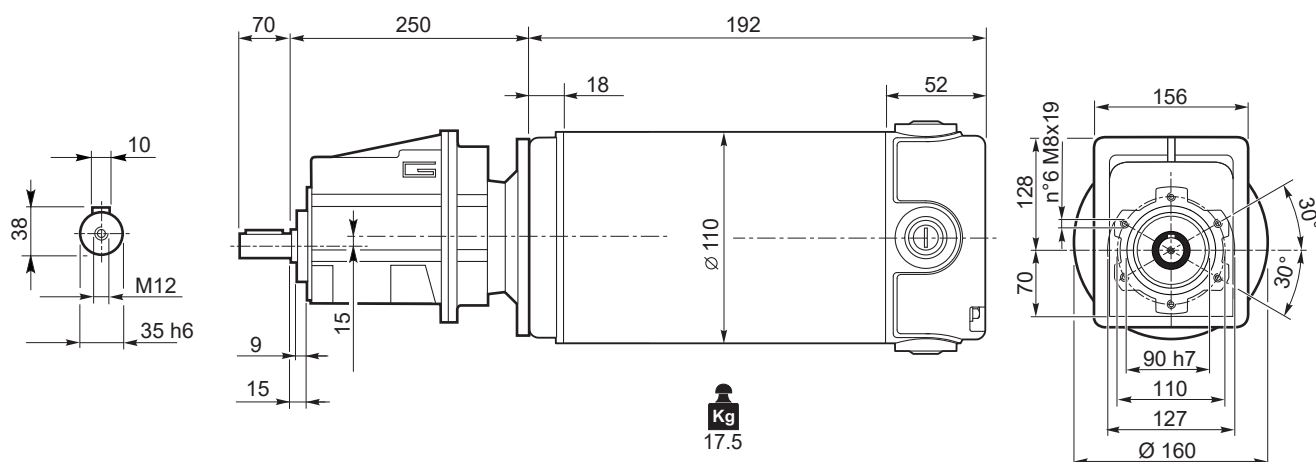

ECMG350/043 U

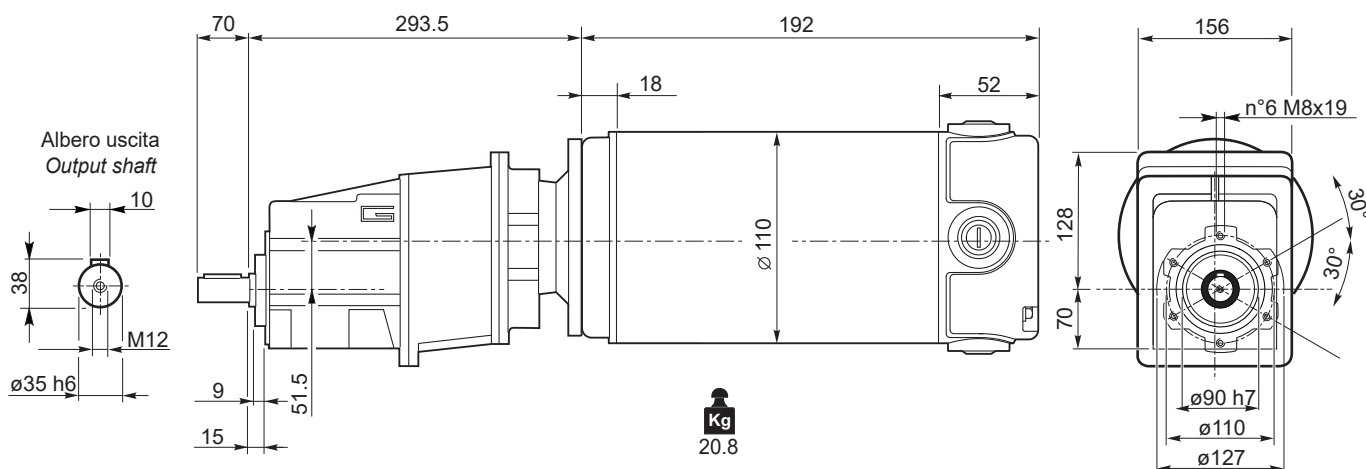

Freno / Brake

➔ **H23**

ECMG...H

➔ **L30**

ECMG...F

➔ **L31**

ECMG...H/F

➔ **L32**

Motori / Motors IP66

➔ **I10**

Nota: Motore IP66 non disponibile per ECMG350/042
Note: IP66 motor not available for ECMG350/042

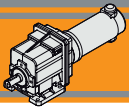

Dimensioni

Dimensions

ECMG..U

ECMG600/002 U

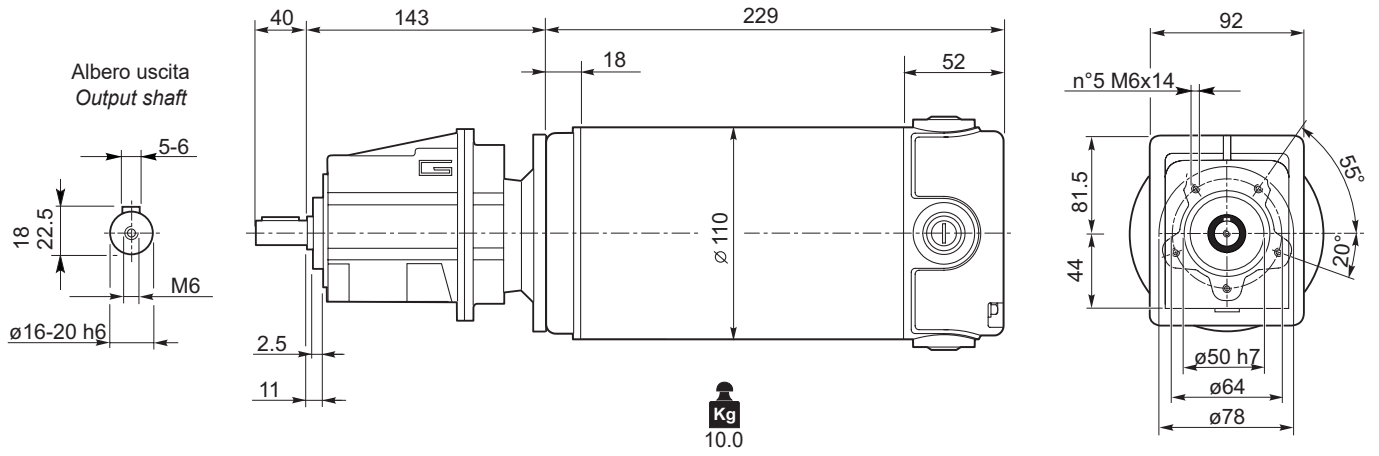

ECMG600/002 U

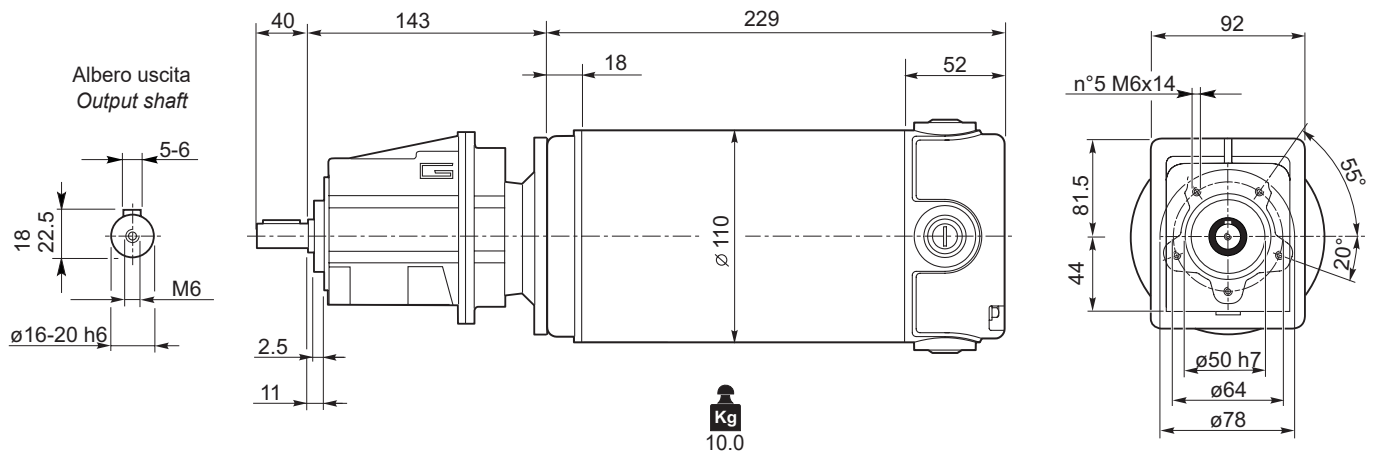

Freno / Brake



H23

Motori / Motors IP66



I12

ECMG...H



L30

ECMG...F



L31

ECMG...H/F



L32

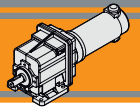

Dimensioni

Dimensions

ECMG..U

ECMG600/012 U

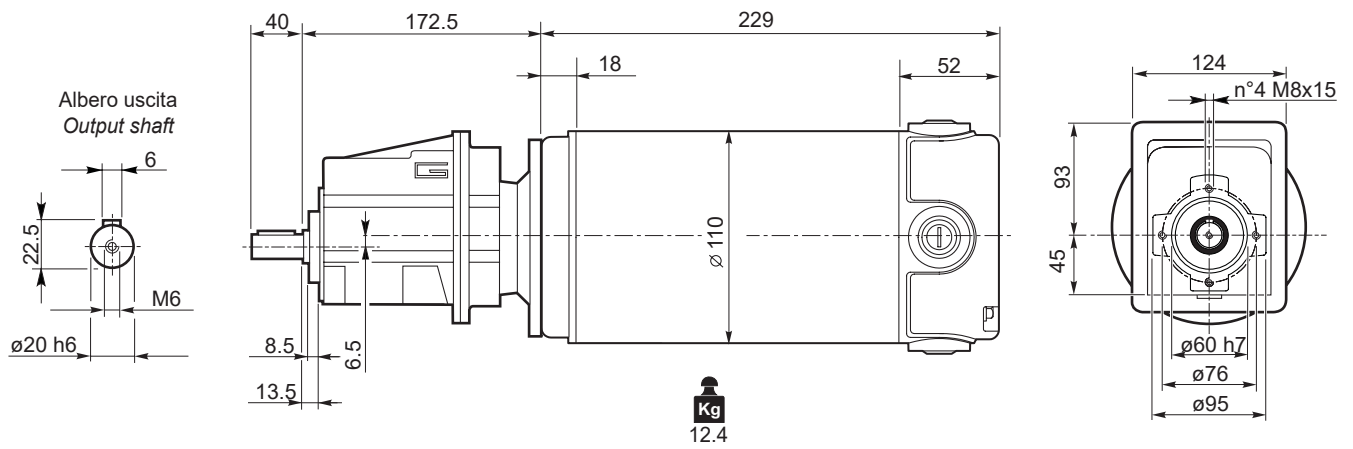

ECMG600/013 U

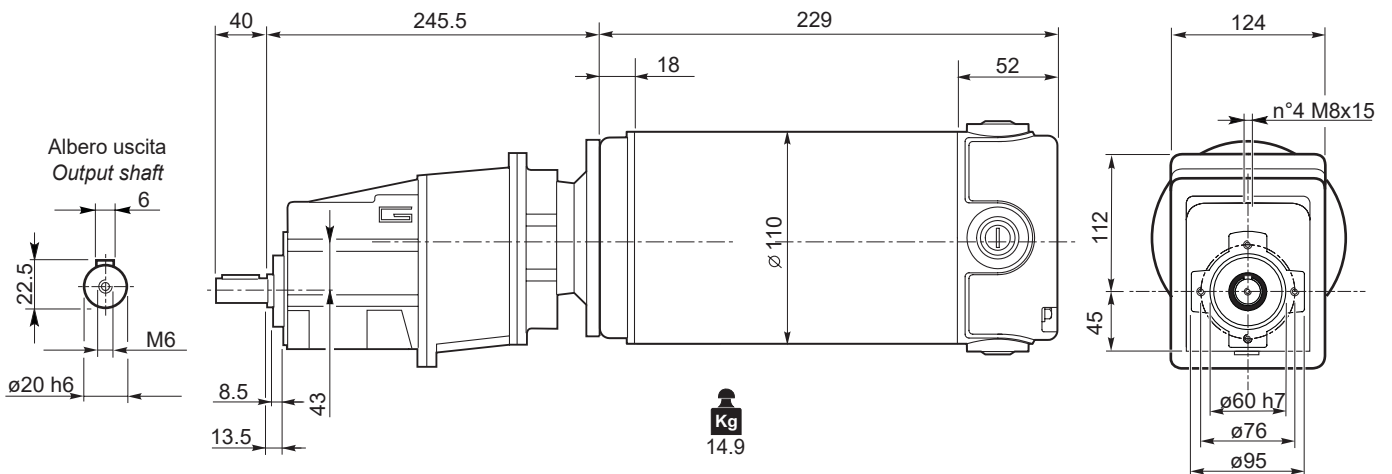

ECMG

Freno / Brake



H23

Motori / Motors IP66



I12

ECMG...H



L30

ECMG...F



L31

ECMG...H/F



L32

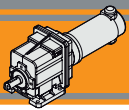

Dimensioni

Dimensions

ECMG..U

ECMG600/022 U

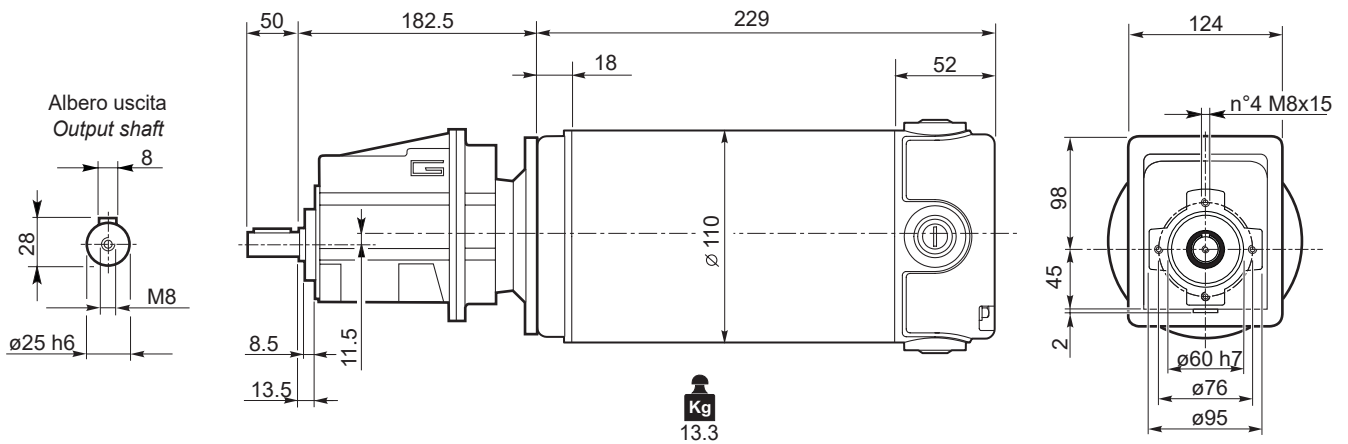

ECMG600/023 U

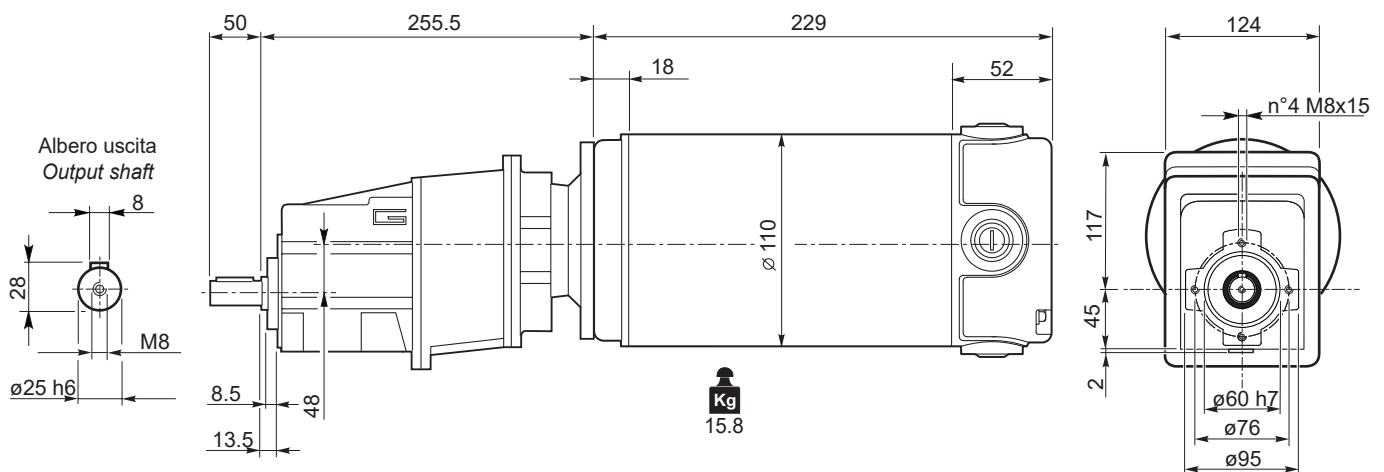

ECMG600/032 U

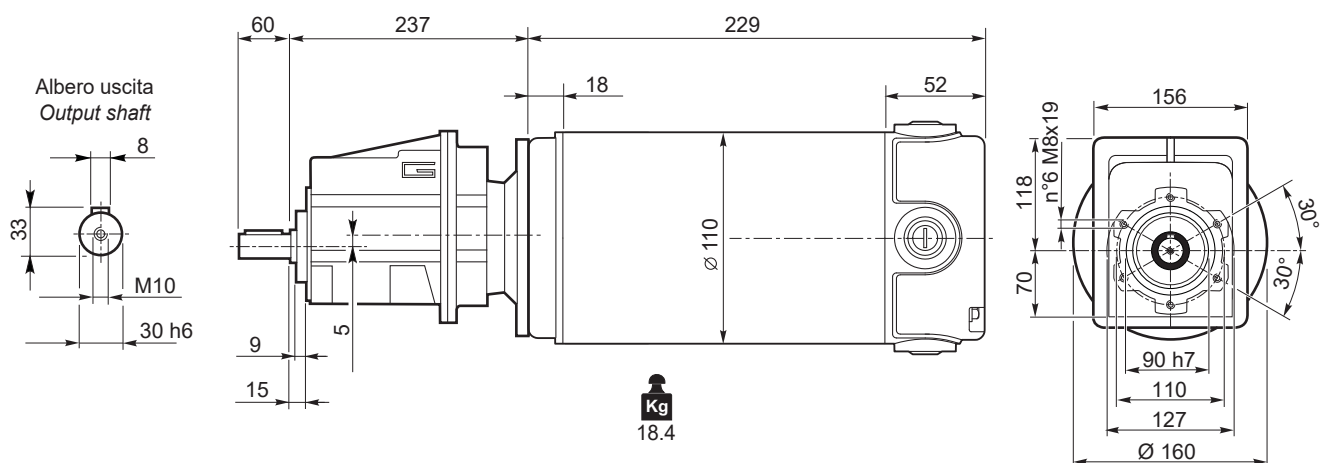

Freno / Brake



H23

ECMG...H



L30

ECMG...F



L31

ECMG...H/F



L32

Motori / Motors IP66



I12

Nota: Motore IP66 non disponibile per ECMG600/032
Note: IP66 motor not available for ECMG600/032

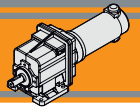

Dimensioni

Dimensions

ECMG..U

ECMG600/033 U

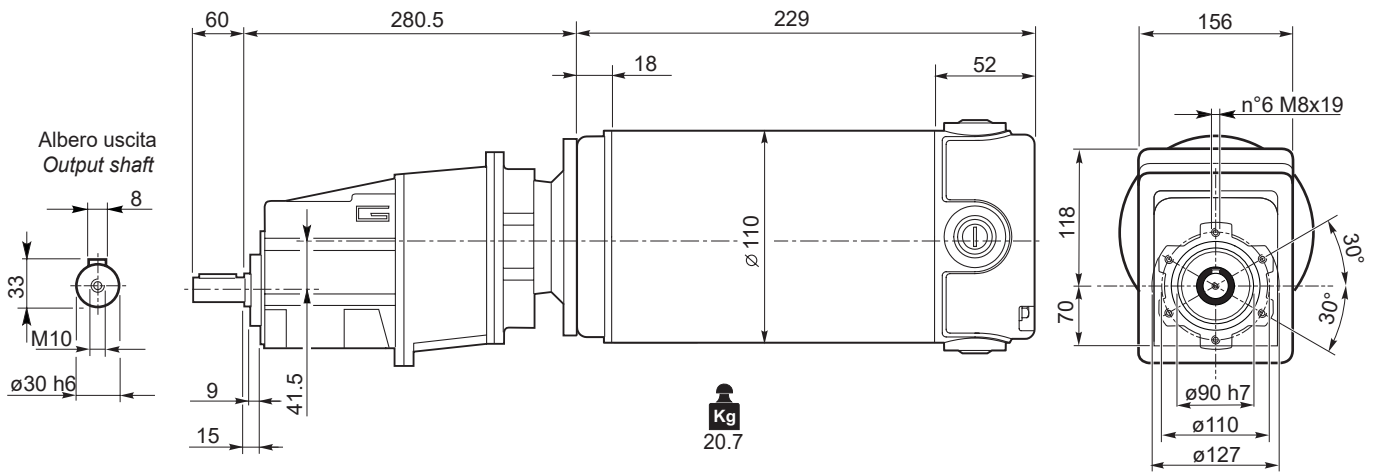

ECMG600/042 U

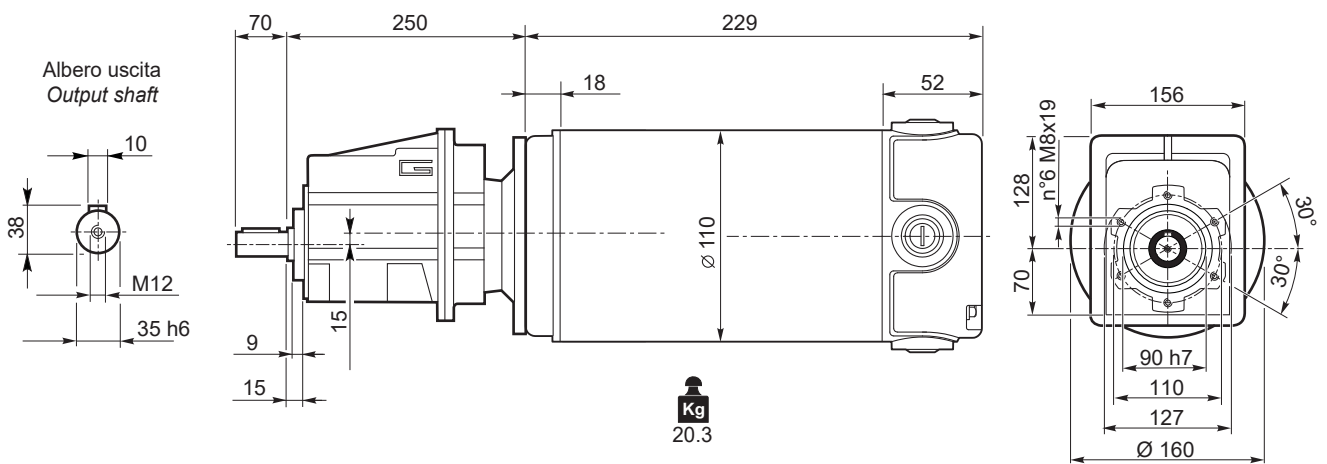

ECMG600/043 U

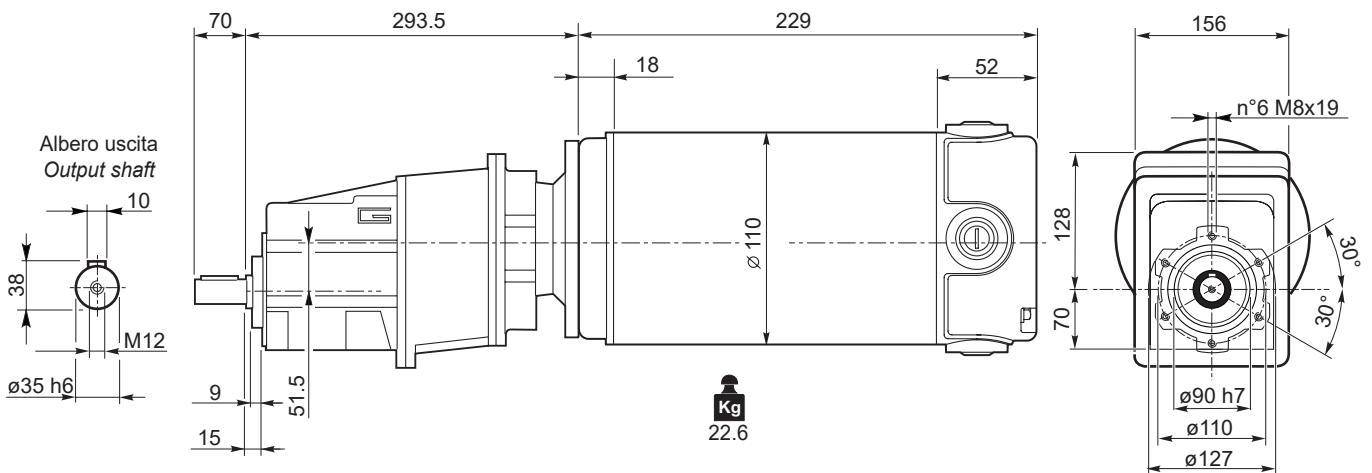

Freno / Brake

→ **H23**

ECMG...H

→ **L30**

ECMG...F

→ **L31**

ECMG...H/F

→ **L32**

Motori / Motors IP66

→ **I12**

Nota: Motore IP66 non disponibile per ECMG600/042
Note: IP66 motor not available for ECMG600/042

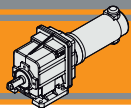

Dimensioni

Dimensions

ECMG..H

ECMG..2 H..

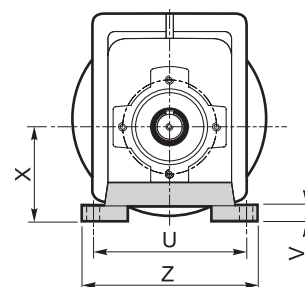
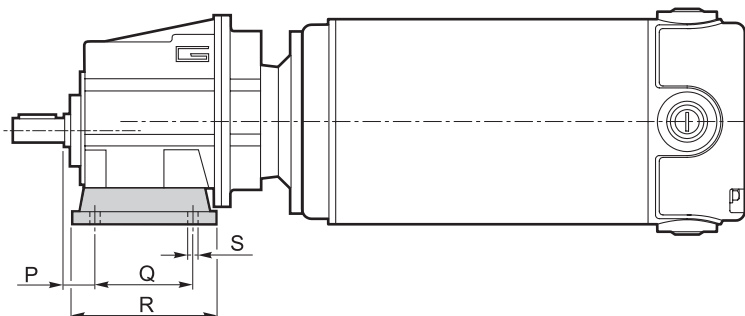

ECMG..3 H..

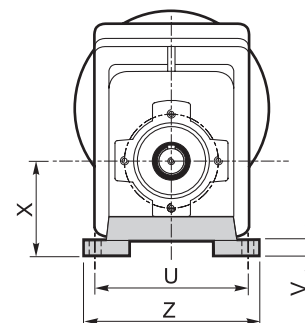
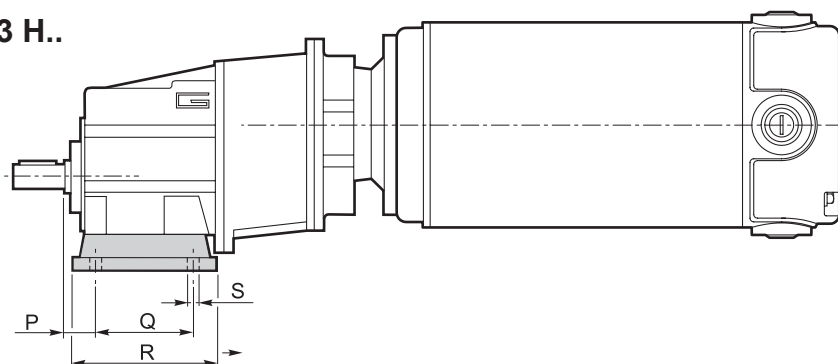

Versione H / H Version

CMG	P	Q	R	S	U	V	X	Z	Piede / Foot	
									Tipo / Type	Peso / Weight [kg]
002	18	60	80	9	100	10	60	120	H60	0.2
	18	80	104	9	110 - 120	10	75	145	H75	0.3
	18	50 - 87	110	9	110	10	85	135	H85	0.4
012 013	20	85	108	9	115	12	65	139	H65	0.7
	18	80	118	9	110	12	75	140	H75	1.0
	25	85	120	9	120	12	80	140	H80	1.1
	18	50 - 87	118	9	110	12	85	130	H85	1.2
	25	130	154	9	110	12	90	135	H90	1.5
022 023	18	60 - 107.5	135	11	130	12	100	155	H100	1.7
	20	85	108	9	115	12	65	139	H65	0.7
	18	80	118	9	110	12	75	140	H75	1.0
	25	85	120	9	120	12	80	140	H80	1.1
	18	50 - 87	118	9	110	12	85	130	H85	1.2
032 033	25	130	154	9	110	12	90	135	H90	1.5
	18	60 - 107.5	135	11	130	12	100	155	H100	1.7
	30	105	136	14	160	14	95	194	H95	1.5
	30	100	150	11	150	14	110	185	H110	1.9
	18	70			160					
30	165	195	14	135	14	115	170	H115	2.2	
35	110	160	14	170	14	120	210	H120	2.6	
042 043	30	105	136	14	160	14	95	194	H95	1.5
	30	100	150	11	150	14	110	185	H110	1.9
	18	70			160					
	30	165	195	14	135	14	115	170	H115	2.2
35	110	160	14	170	14	120	210	H120	2.6	

Preferenziale / Preferred

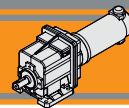

Dimensioni

Dimensions

ECMG..F

ECMG..2 F..

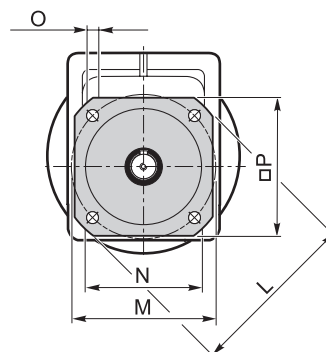
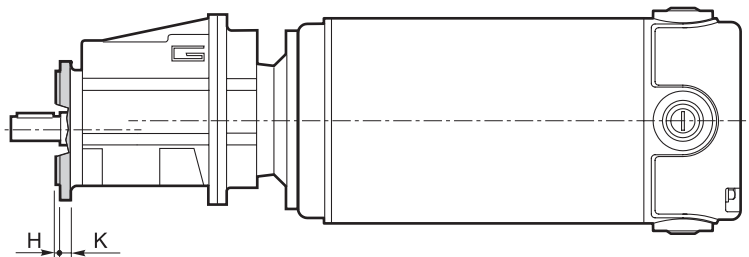

ECMG..3 F..

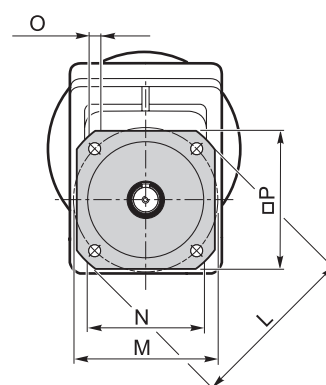
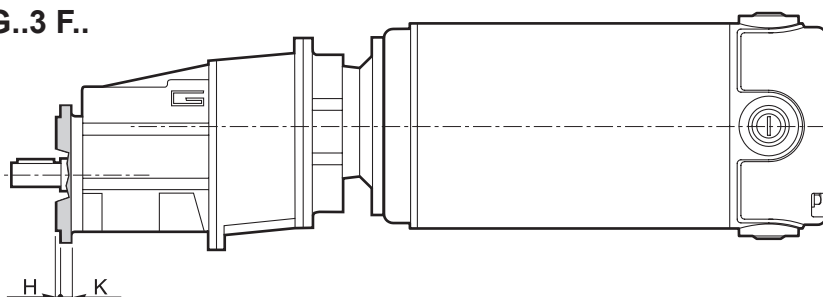

Versione F / F Version									
CMG	H	K	L	M	N f7	O	P	Flangia / Flange	
								Tipo / Type	Peso / Weight [kg]
002	3.5	7	105	85	70	6.5	90	F105	0.1
	3.5	8	120	100	80	7	100	F120	0.2
	3.5	8	140	115	95	9	115	F140	0.2
012 013	3	9	120	100	80	9	106	F120	0.5
	3.5	9	140	115	95	9	115	F140	0.8
	3.5	9	160	130	110	9	126	F160	1.1
	3.5	11	200	165	130	11	165	F200	1.8
022 023	3	9	120	100	80	9	106	F120	0.5
	3.5	9	140	115	95	9	115	F140	0.8
	3.5	9	160	130	110	9	126	F160	1.1
	3.5	11	200	165	130	11	165	F200	1.8
032 033	3.5	11	160	130	110	9	140	F160	1.0
	3.5	11	200	165	130	11	165	F200	1.8
	4	13	250	215	180	14	215	F250	2.9
042 043	3.5	11	160	130	110	9	140	F160	1.0
	3.5	11	200	165	130	11	165	F200	1.8
	4	13	250	215	180	14	215	F250	2.9

ECMG

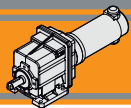

Dimensioni

Dimensions

Versione H / H Version											Combinazioni possibili H/F Possible combinations H/F						
CMG	P	Q	R	S	U	V	X	Z	Piede / Foot		F105	F120	F140	F160	F200	F250	F300
									Tipo / Type	Peso / Weight [kg]							
002	18	60	80	9	100	10	60	120	H60	0.2	•	•	•				
	18	80	104	9	110 - 120	10	75	145	H75	0.3	•	•	•				
	18	50 - 87	110	9	110	10	85	135	H85	0.4	•	•	•				
012 013	20	85	108	9	115	12	65	139	H65	0.7		•	•				
	18	80	118	9	110	12	75	140	H75	1.0		•	•	•			
	25	85	120	9	120	12	80	140	H80	1.1		•	•	•			
	18	50 - 87	118	9	110	12	85	130	H85	1.2		•	•	•			
	25	130	154	9	110	12	90	135	H90	1.5		•	•	•	•		
	18	60 - 107.5	135	11	130	12	100	155	H100	1.7		•	•	•	•		
022 023	20	85	108	9	115	12	65	139	H65	0.7		•	•				
	18	80	118	9	110	12	75	140	H75	1.0		•	•	•			
	25	85	120	9	120	12	80	140	H80	1.1		•	•	•			
	18	50 - 87	118	9	110	12	85	130	H85	1.2		•	•	•			
	25	130	154	9	110	12	90	135	H90	1.5		•	•	•	•		
	18	60 - 107.5	135	11	130	12	100	155	H100	1.7		•	•	•	•		
032 033	30	105	136	14	160	14	95	194	H95	1.5				•	•		
	30	100	150	11	150	14	110	185	H110	1.9				•	•		
	18	70			160												
	30	165	195	14	135	14	115	170	H115	2.2				•	•	•	
	35	110	160	14	170	14	120	210	H120	2.6				•	•	•	
042 043	30	105	136	14	160	14	95	194	H95	1.5				•	•		
	30	100	150	11	150	14	110	185	H110	1.9				•	•		
	18	70			160												
	30	165	195	14	135	14	115	170	H115	2.2				•	•	•	
	35	110	160	14	170	14	120	210	H120	2.6				•	•	•	

■ Preferenziale / Preferred

• Combinazioni possibili H/F / Possible combinations H/F

Versione F / F Version									
CMG	H	K	L	M	N f7	O	P	Flangia / Flange	
								Tipo / Type	Peso / Weight [kg]
002	3.5	7	105	85	70	6.5	90	F105	0.1
	3.5	8	120	100	80	7	100	F120	0.2
	3.5	8	140	115	95	9	115	F140	0.2
012 013	3	9	120	100	80	9	106	F120	0.5
	3.5	9	140	115	95	9	115	F140	0.8
	3.5	9	160	130	110	9	126	F160	1.1
	3.5	11	200	165	130	11	165	F200	1.8
022 023	3	9	120	100	80	9	106	F120	0.5
	3.5	9	140	115	95	9	115	F140	0.8
	3.5	9	160	130	110	9	126	F160	1.1
	3.5	11	200	165	130	11	165	F200	1.8
032 033	3.5	11	160	130	110	9	140	F160	1.0
	3.5	11	200	165	130	11	165	F200	1.8
	4	13	250	215	150	14	215	F250	2.9
042 043	3.5	11	160	130	110	9	140	F160	1.0
	3.5	11	200	165	130	11	165	F200	1.8
	4	13	250	215	150	14	215	F250	2.9

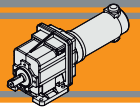

Dimensioni

Dimensions

ECMG..H../F..

ECMG..2 H../F..

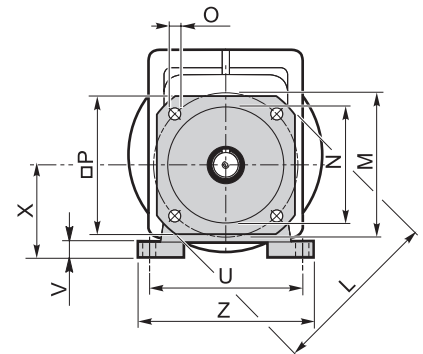
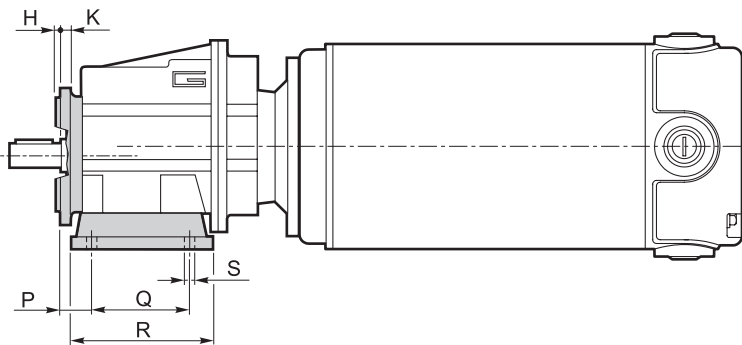

ECMG..3 H../F..

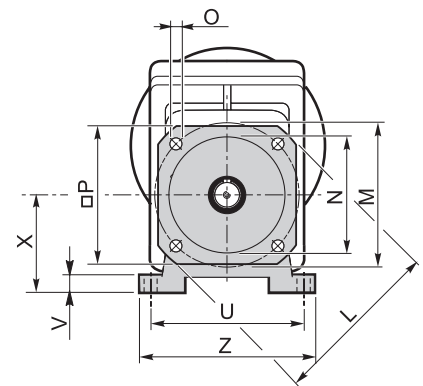
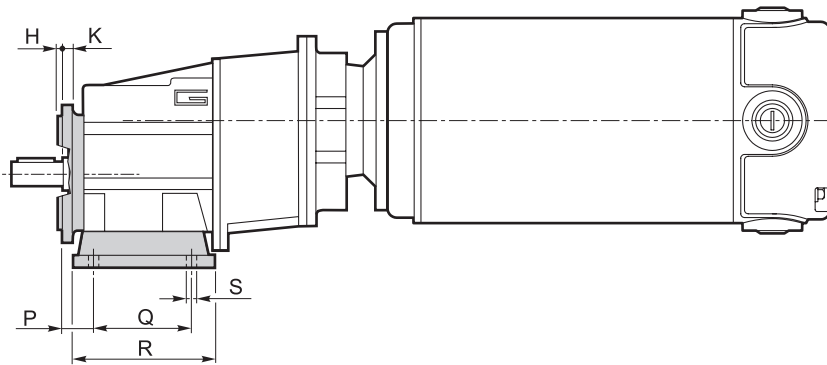



Ferrite

Motoriduttori CC ad assi ortogonali
DC helical bevel gearmotors

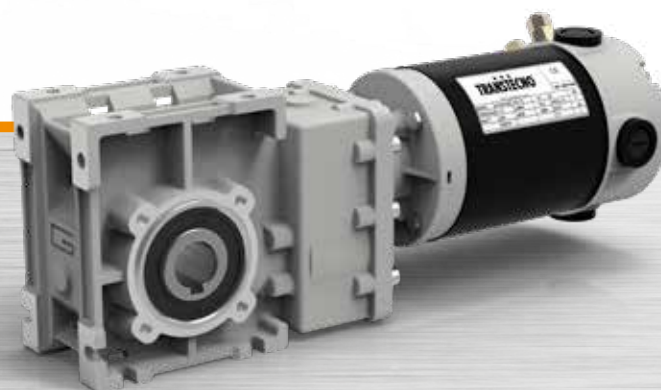

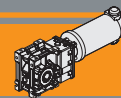

Pag.
Page



Indice	Index	
Caratteristiche tecniche	<i>Technical features</i>	M2
Designazione	<i>Classification</i>	M2
Sensi di rotazione	<i>Direction of rotation</i>	M2
Simbologia	<i>Symbols</i>	M3
Lubrificazione	<i>Lubrication</i>	M3
Carichi radiali	<i>Radial loads</i>	M3
Dati tecnici per servizio S2	<i>Technical data for S2 duty</i>	M4
Motori applicabili	<i>Motor adapters</i>	M6
Dimensioni	<i>Dimensions</i>	M7
Accessori	<i>Accessories</i>	M18

Questa sezione annulla e sostituisce ogni precedente edizione o revisione. Qualora questa sezione non Vi sia giunta in distribuzione controllata, l'aggiornamento dei dati ivi contenuto non è assicurato. **In tal caso la versione più aggiornata è disponibile sul nostro sito internet www.transtecno.com**

This section replaces any previous edition and revision. If you obtained this catalogue other than through controlled distribution channels, the most up to date content is not guaranteed. In this case the latest version is available on our web site www.transtecno.com

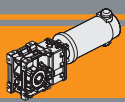

Caratteristiche tecniche

Technical features

Le caratteristiche principali dei motoriduttori CC ad assi ortogonali a magneti permanenti in ferrite serie ECMB sono:

The main features of ECMB ferrite permanent magnets DC helical bevel gearmotors range are:

- Alimentazione in bassa tensione 12/24 Vcc
- Possibilità di montaggio encoder
- Potenze motore disponibili da 100 a 800W S2
- Magneti in ferrite
- Carcasse dei riduttori in pressofusione di alluminio
- Lubrificazione permanente con olio sintetico
- Ingranaggi sempre rettificati

- Low voltage power supply 12/24 Vdc
- Suitable for encoder assembly
- Motor power ratings available from 100 to 800W S2
- Ferrite magnets
- Die-cast aluminum housing
- Permanent synthetic oil long-life lubrication
- Ground helical gears

Designazione

Classification

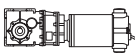
MOTORIDUTTORE / GEARMOTOR													
ECMB	100/402						U	9.2	D20	SZDX	BRSX	90	240
Tipo Type	Grandezza Size						Versione Riduttore Gearbox Version	Rapporto Ratio	Albero di uscita Output shaft	Albero di uscita Output shaft	Braccio di reazione Torque arm	Angolo Angle	Versione Motore Motor Version
	070/402	100/402	180/402	250/402	350/402	600/402	U	Vedere tabella	Vedere tabella	SZDX SZSX DZ	BRDX BRSX	0° 90° 180° 270°	120 240 24E
	070/502	100/502	180/502	250/502	350/502	600/502	FD						
	070/633	100/633	180/633	250/633	350/633	600/633	FS FLD FLS FBD FBS	See tables	See tables		*		

Versione Riduttore
Gearbox Version

Albero di uscita
Output shaft

Braccio di reazione
Torque arm *

Angolo
Angle

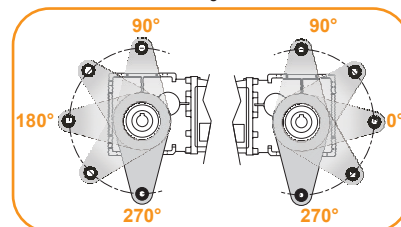
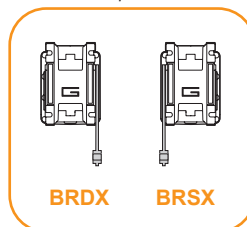
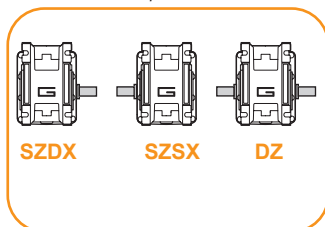
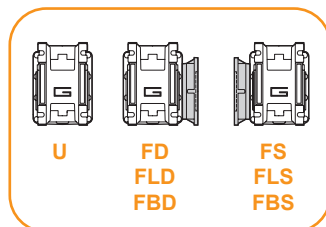

* NOTA: il braccio di reazione viene fornito smontato.
NOTE: the torque arm will be supplied not assembled.

Sensi di rotazione

Direction of rotation

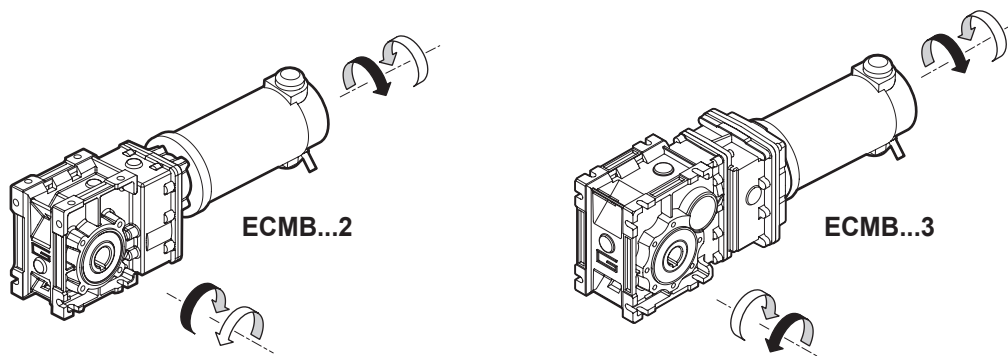

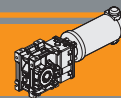

Simbologia

Symbols

n_1 [min ⁻¹]	Velocità in ingresso / <i>Input speed</i>	M_2 [Nm]	Coppia in uscita in funzione di P_1 / <i>Output torque referred to P_1</i>
n_2 [min ⁻¹]	Velocità in uscita / <i>Output speed</i>	sf	Fattore di servizio / <i>Service factor</i>
i	Rapporto di riduzione / <i>Ratio</i>	A_2 [N]	Carico assiale ammissibile in uscita / <i>Permitted output axial load</i>
P_1 [kW]	Potenza in entrata / <i>Input power</i>	R_2 [N]	Carico radiale ammissibile in uscita / <i>Permitted output radial load</i>

Lubrificazione

Lubrication

Tutti i riduttori nelle taglie 402, 502 e 633 sono forniti completi di lubrificante sintetico viscosità 320, pertanto possono essere installati in qualunque posizione di montaggio e non necessitano di manutenzione.

Permanent synthetic oil long-life lubrication (viscosity grade 320) makes it possible to use sizes 402, 502 and 603 in all mounting positions; for this reason they can be installed in any assembly position and do not require maintenance.

Carichi radiali

Radial loads

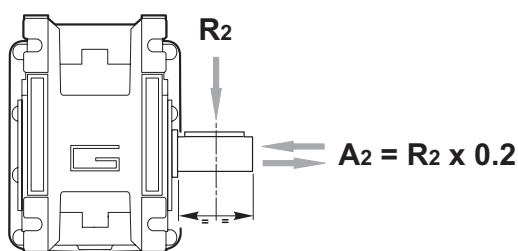

n_2 [min ⁻¹]	R_2 [N]			
	CMB 402	CMB 502	CMB 633	CMB 903
400	905	1116	1835	2682
300	996	1228	2020	2952
200	1141	1406	2312	3379
170	1204	1484	2441	3567
140	1414	1743	2604	3806
100	1582	1949	2913	4686
90	1638	2019	3321	4853
60	2047	2490	3801	5556
40	2524	3029	4492	6614
30	2778	3334	5159	7540
20	3180	3816	5906	8631
15	3500	4200	6500	9500
10	3500	4200	6500	9500

Quando il carico radiale risultante non è applicato sulla mezza-ria dell'albero occorre calcolare quello effettivo con la seguente formula:

When the resulting radial load is not applied on the centre line of the shaft it is necessary to calculate the effective load with the following formula:

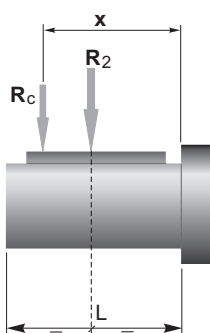

	CMB 402	CMB 502	CMB 633	CMB 903
a	86	104	118	157
b	66	79	93	117
R_{2MAX}	3500	4200	6500	9500

$$R_c = \frac{R_2 \cdot a}{(b + x)} \leq R_{2MAX}$$

$$R \leq R_c$$

*a, b = valori riportati nella tabella
a, b = values given in the table*

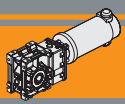

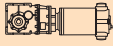

Dati tecnici per servizio S2

Technical data for S2 duty

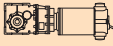
P ₁ [W]	n ₂ [min ⁻¹]	M ₂ [Nm]	sf	i		Versione motore Motor version
100						
(3000 min ⁻¹)	485	1.8	16.8	6.18	070/402	12E/24E
	401	2.2	13.8	7.49		
	326	2.8	11.3	9.20		
	254	3.5	9.9	11.83		
	240	3.7	9.4	12.48		
	202	4.4	7.9	14.83		
	170	5.3	6.6	17.63		
	161	5.6	7.7	18.60		
	134	6.7	6.4	22.33		
	125	7.2	6.0	23.91		
	104	8.6	5.9	28.89		
	97	9.2	5.5	30.84		
	89	10	5.1	33.57		
	84	11	4.8	35.63		
	70	13	4.0	42.75		
	54	17	3.1	55.31		
	51	18	2.9	59.06		
	47	19	2.7	64.29		
	41	22	2.4	72.50		
	54	17	5.9	55.31	070/502	12E/24E
	51	18	5.5	59.06		
	47	19	5.1	64.29		
	41	22	4.5	72.50		
	41	22	8.8	73.96	070/633	12E/24E
	38	24	8.3	78.58		
	32	28	7.0	93.33		
	21	42	4.6	140.52		
	17	54	3.6	181.81		
	14	63	3.1	211.31		
	13	71	2.7	238.31		

P ₁ [W]	n ₂ [min ⁻¹]	M ₂ [Nm]	sf	i		Versione motore Motor version
140						
(3000 min ⁻¹)	41	31	6.3	73.96	100/633	120/240/24E
	38	33	5.9	78.58		
	32	39	5.0	93.33		
	21	59	3.3	140.52		
	17	76	2.6	181.81		
	14	89	2.2	211.31		
	13	100	2.0	238.31		

P ₁ [W]	n ₂ [min ⁻¹]	M ₂ [Nm]	sf	i		Versione motore Motor version		
250								
(3000 min ⁻¹)	485	4.6	6.7	6.18	180/402	120/240/24E		
	401	5.6	5.5	7.49				
	326	6.9	4.5	9.20				
	254	8.8	4.0	11.83				
	240	9.3	3.7	12.48				
	202	11	3.2	14.83				
	170	13	2.7	17.63				
	161	14	3.1	18.60				
	134	17	2.6	22.33				
	125	18	2.4	23.91				
	104	22	2.4	28.89				
	97	23	2.2	30.84				
	89	25	2.0	33.57				
	84	27	1.9	35.63				
	70	32	1.6	42.75				
	54	41	1.2	55.31				
	51	44	1.2	59.06				
	47	48	1.1	64.29				
	41	54	0.9	72.50				
	134	17	5.1	22.33			180/502	120/240/24E
	125	18	4.8	23.91				
	104	22	4.5	28.89				
	97	23	4.2	30.84				
	89	25	3.9	33.57				
	84	27	3.7	35.63				
	70	32	3.1	42.75				
	54	41	2.4	55.31				
	51	44	2.2	59.06				
	47	48	2.0	64.29				
	41	54	1.8	72.50				
	52	43	4.5	57.93	180/633	120/240/24E		
	49	46	4.2	61.63				
	41	55	3.5	73.96				
	38	59	3.3	78.58				
	32	70	2.8	93.33				
	21	105	1.9	140.52				
	17	136	1.4	181.81				
	14	158	1.2	211.31				
	13	178	1.1	238.31				

P ₁ [W]	n ₂ [min ⁻¹]	M ₂ [Nm]	sf	i		Versione motore Motor version
140						
(3000 min ⁻¹)	485	2.6	12.0	6.18	100/402	120/240/24E
	401	3.1	9.9	7.49		
	326	3.9	8.0	9.20		
	254	5.0	7.1	11.83		
	240	5.2	6.7	12.48		
	202	6.2	5.6	14.83		
	170	7.4	4.7	17.63		
	161	7.8	5.5	18.60		
	134	9.4	4.6	22.33		
	125	10	4.3	23.91		
	104	12	4.2	28.89		
	97	13	3.9	30.84		
	89	14	3.6	33.57		
	84	15	3.4	35.63		
	70	18	2.8	42.75		
	54	23	2.2	55.31		
	51	25	2.1	59.06		
	47	27	1.9	64.29		
	41	30	1.7	72.50		
	54	23	4.2	55.31	100/502	120/240/24E
	51	25	4.0	59.06		
	47	27	3.6	64.29		
	41	30	3.2	72.50		

NOTA: per servizio continuo o altamente intermittente, contattare il servizio tecnico

NOTE: for continuous or highly intermittent duty, please contact our technical service

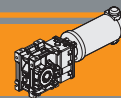

Dati tecnici per servizio S2

Technical data for S2 duty

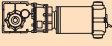
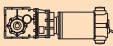
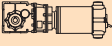
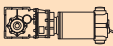
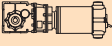
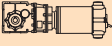
P ₁ [W]	n ₂ [min ⁻¹]	M ₂ [Nm]	sf	i		Versione motore Motor version	P ₁ [W]	n ₂ [min ⁻¹]	M ₂ [Nm]	sf	i		Versione motore Motor version
350							500						
(3000 min ⁻¹)	485	6.5	4.8	6.18		250/402	(3000 min ⁻¹)	485	9	3.4	6.18		350/402
	401	7.8	4	7.49				401	11	2.8	7.49		
	326	9.6	3.2	9.20				326	14	2.3	9.2		
	254	12	2.8	11.83				254	18	2.0	11.83		
	240	13	2.7	12.48				240	19	1.9	12.48		
	202	16	2.3	14.83				202	22	1.6	14.83		
	170	19	1.9	17.63				170	26	1.3	17.63		
	161	20	2.2	18.60				161	28	1.5	18.6		
	134	23	1.8	22.33				134	33	1.3	22.33		
	125	25	1.7	23.91				125	36	1.2	23.91		
	104	30	1.7	28.89				104	43	1.2	28.89		
	97	32	1.6	30.84				97	46	1.1	30.84		
	89	35	1.5	33.57				89	50	1.0	33.57		
	84	37	1.4	35.63				84	53	1.0	35.63		
	70	45	1.1	42.75				70	64	0.8	42.75		
	54	58	0.9	55.31				54	73	0.7	55.31		
	51	62	0.8	59.06				51	73	0.7	59.06		
	47	67	0.8	64.29				47	73	0.7	64.29		
	41	72	0.7	72.50				41	73	0.7	64.29		
	485	6.5	8.5	6.18				250/502		326	14		
	401	7.8	7.0	7.49		254			18	4.0	11.83		
	326	9.6	5.7	9.2		240			19	3.7	12.48		
	254	12	5.7	11.83		202			22	3.2	14.83		
	240	13	5.4	12.48		170			26	2.7	17.63		
	202	16	4.5	14.83		161			28	3.1	18.60		
	170	19	3.8	17.63		134			33	2.6	22.33		
	161	20	4.4	18.6		125			36	2.4	23.91		
	134	23	3.7	22.33		104			43	2.3	28.89		
	125	25	3.4	23.91		97			46	2.1	30.84		
	104	30	3.2	28.89		89			50	2.0	33.57		
	97	32	3.0	30.84		84			53	1.8	35.63		
	89	35	2.8	33.57		70			64	1.5	42.75		
	84	37	2.6	35.63		54			83	1.2	55.31		
	70	45	2.2	42.75		51			88	1.1	59.06		
	54	58	1.7	55.31		47			96	1.0	64.29		
	51	62	1.6	59.06		41			109	0.9	72.50		
	47	67	1.5	64.29									
	41	76	1.3	72.50									
	106	30	5.8	28.17		250/633				139	32	5.3	21.56
	89	35	4.9	33.81				113	40	4.3	26.48		
	84	38	4.6	35.92				106	42	4.1	28.17		
	77	41	4.8	38.88				89	51	3.4	33.81		
	64	49	4.0	47.16				84	54	3.2	35.92		
	52	61	3.2	57.93				77	58	3.4	38.88		
	49	65	3.0	61.63				64	71	2.8	47.16		
	41	78	2.5	73.96				52	87	2.2	57.93		
	38	82	2.4	78.58				49	92	2.1	61.63		
	32	98	2.0	93.33				41	111	1.8	73.96		
	21	147	1.3	140.52				38	118	1.7	78.58		
	17	190	1.0	181.81				32	140	1.4	93.33		
	14	221	0.9	211.31				21	210	0.9	140.52		
	13	250	0.8	238.31				17	272	0.7	181.81		
						14	279	0.7	211.31				

NOTA: per servizio continuo o altamente intermittente, contattare il servizio tecnico

NOTE: for continuous or highly intermittent duty, please contact our technical service

NOTA

Verificare sempre che la coppia M₂ utilizzata non ecceda il valore indicato nelle caselle in grigio

NOTE

Please check that the output torque M₂ does not exceed the value in the grey areas

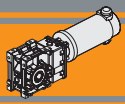

Dati tecnici per servizio S2

Technical data for S2 duty

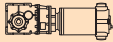
P ₁ [W]	n ₂ [min ⁻¹]	M ₂ [Nm]	sf	i		Versione motore Motor version
500						
(3000 min ⁻¹)	63	71	5.5	47.25	3350/903	120/240
	52	86	4.5	57.52		
	45	99	3.9	66.17		
	36	124	3.1	83.2		
	28	162	2.4	108.09		
	23	198	2.0	132.23		
	20	221	1.8	147.92		
	18	250	1.6	167.09		
	16	286	1.4	191.06		
	14	332	1.2	221.88		
	11	393	1.0	262.96		

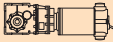
P ₁ [W]	n ₂ [min ⁻¹]	M ₂ [Nm]	sf	i		Versione motore Motor version		
800								
(3000 min ⁻¹)	97	74	1.3	30.84	600/502	120/240		
	89	80	1.2	33.57				
	84	85	1.1	35.63				
	70	102	1.0	42.75				
	54	132	0.7	55.31				
	51	140	0.7	59.06				
	47	140	0.7	64.29				
	41	140	0.7	72.50				
	306	23	5.0	9.81			600/633	120/240
	287	25	4.7	10.44				
	239	30	3.9	12.53				
	225	32	3.7	13.31				
	190	38	3.5	15.81				
	169	43	4.0	17.77				
	139	52	3.3	21.56				
	113	63	2.7	26.48				
	106	67	2.6	28.17				
	89	81	2.1	33.81				
	84	86	2.0	35.92				
	77	93	2.1	38.88				
	64	113	1.7	47.16				
	52	139	1.4	57.93				
	49	148	1.3	61.63				
	41	177	1.1	73.96				
	38	188	1.0	78.58				
	32	223	0.9	93.33				
	21	279	0.7	140.52				
	114	63	5.6	26.30	600/903	120/240		
	99	72	4.8	30.25				
	76	94	4.1	39.26				
	63	113	3.4	47.25				
	52	138	2.8	57.52				
	45	158	2.5	66.17				
	36	199	2.0	83.20				
	28	259	1.5	108.09				
	23	317	1.2	132.23				
	20	354	1.1	147.92				
	18	400	1.0	167.09				
	16	457	0.9	191.06				
	14	531	0.7	221.88				
	11	557	0.7	262.96				

800								
(3000 min ⁻¹)	485	15	2.1	6.18	600/402	120/240		
	401	18	1.7	7.49				
	326	22	1.4	9.20				
	254	28	1.2	11.83				
	240	30	1.2	12.48				
	202	36	1.0	14.83				
	170	42	0.8	17.63				
	161	45	1.0	18.60				
	134	53	0.8	22.33				
	125	57	0.8	23.91				
	104	69	0.7	28.89				
	97	73	0.7	30.84				
	89	73	0.7	33.57				
	84	73	0.7	35.63				
	70	73	0.7	42.75				
	485	15	3.7	6.18			600/502	120/240
	401	18	3.1	7.49				
	326	22	2.5	9.20				
	254	28	2.5	11.83				
	240	30	2.3	12.48				
	202	36	2.0	14.83				
	170	42	1.7	17.63				
	161	45	1.9	18.60				
	134	53	1.6	22.33				
	125	57	1.5	23.91				
	104	69	1.4	28.89				

NOTA

Verificare sempre che la coppia M₂ utilizzata non ecceda il valore indicato nelle caselle in grigio

NOTE

Please check that the output torque M₂ does not exceed the value in the grey areas

NOTA: per servizio continuo o altamente intermittente, contattare il servizio tecnico

NOTE: for continuous or highly intermittent duty, please contact our technical service

Motori applicabili

Motor adapters

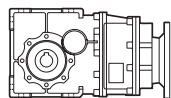
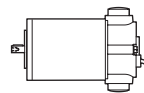

		EC					
		070.12E 070.24E	100.120 100.240 100.24E	180.120 180.240 180.24E	250.120 250.240	350.120 350.240	600.120 600.240
CMB	402	6.18 - 72.50					
	502	6.18 - 72.50					
	633	6.58 - 238.31					
	933						6.65 - 262.96

6.18 - 72.50

Rapporti di riduzione i
Ratio i

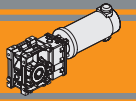

Dimensioni

Dimensions

ECMB070/402 U

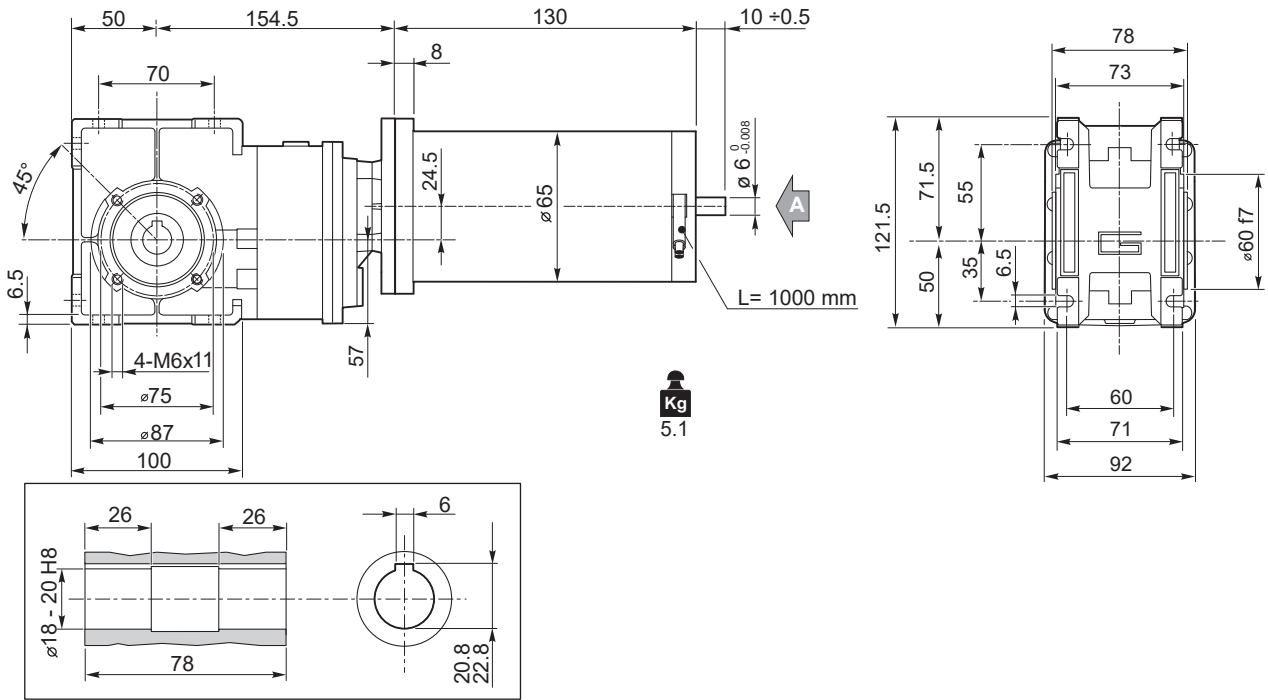

ECMB070/502 U

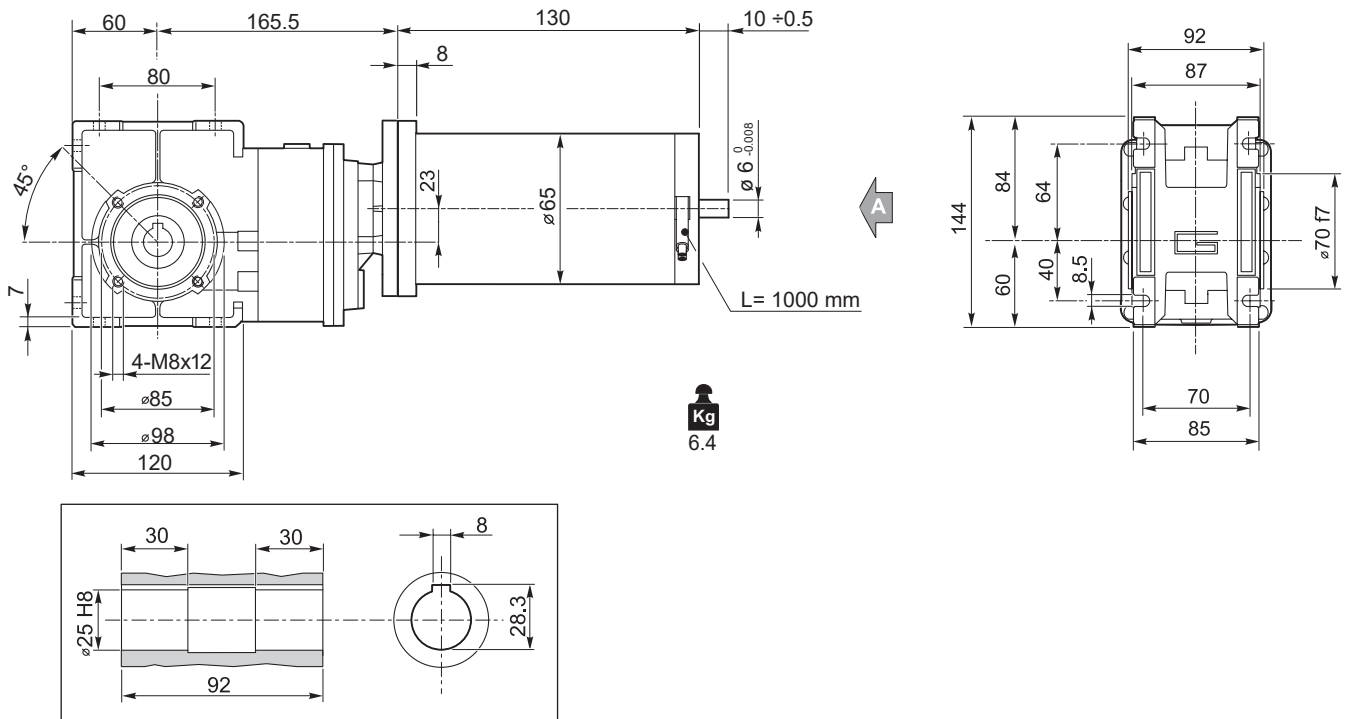

ECMB

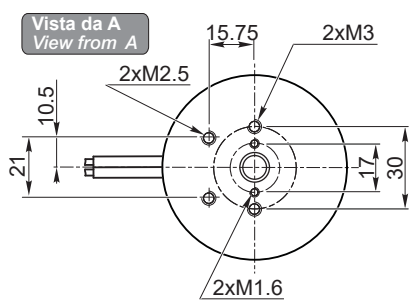

Freno / Brake → H23

Encoder → H24

Motori / Motors IP66 → I2

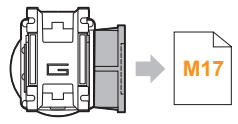

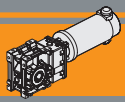

Dimensioni

Dimensions

ECMB070/633 U

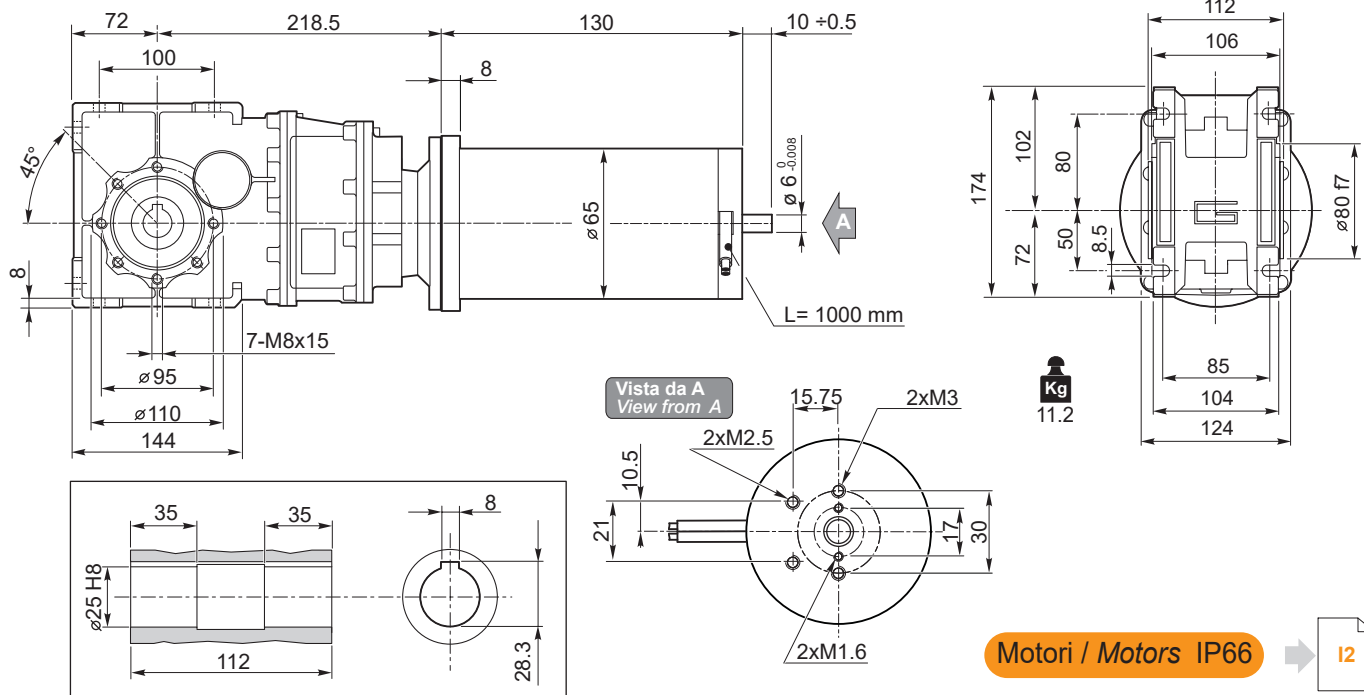

ECMB100/402 U

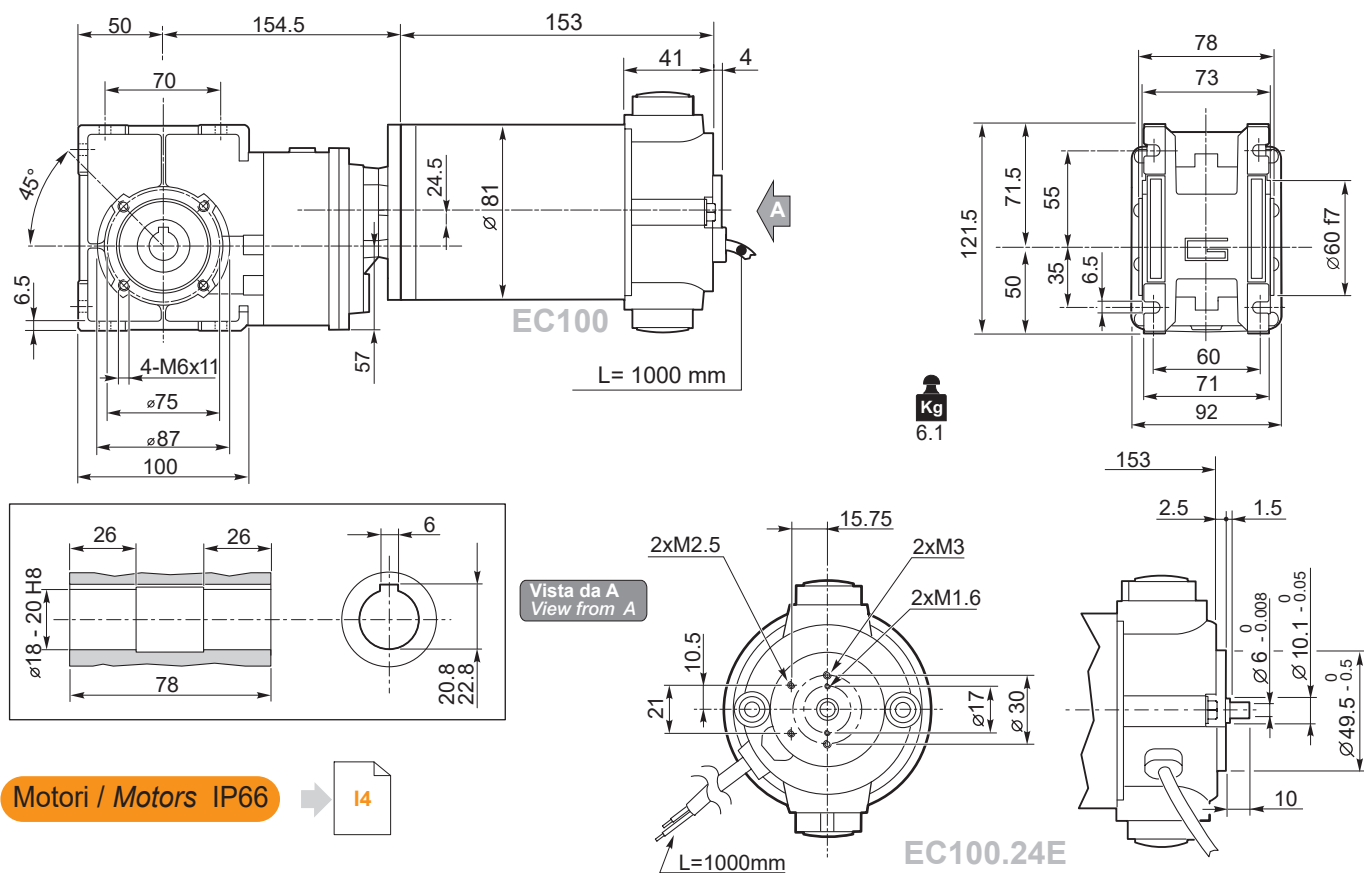

Encoder → H24

Freno / Brake → H23

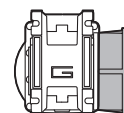

M17

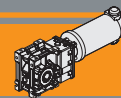

Dimensioni

Dimensions

ECMB100/502 U

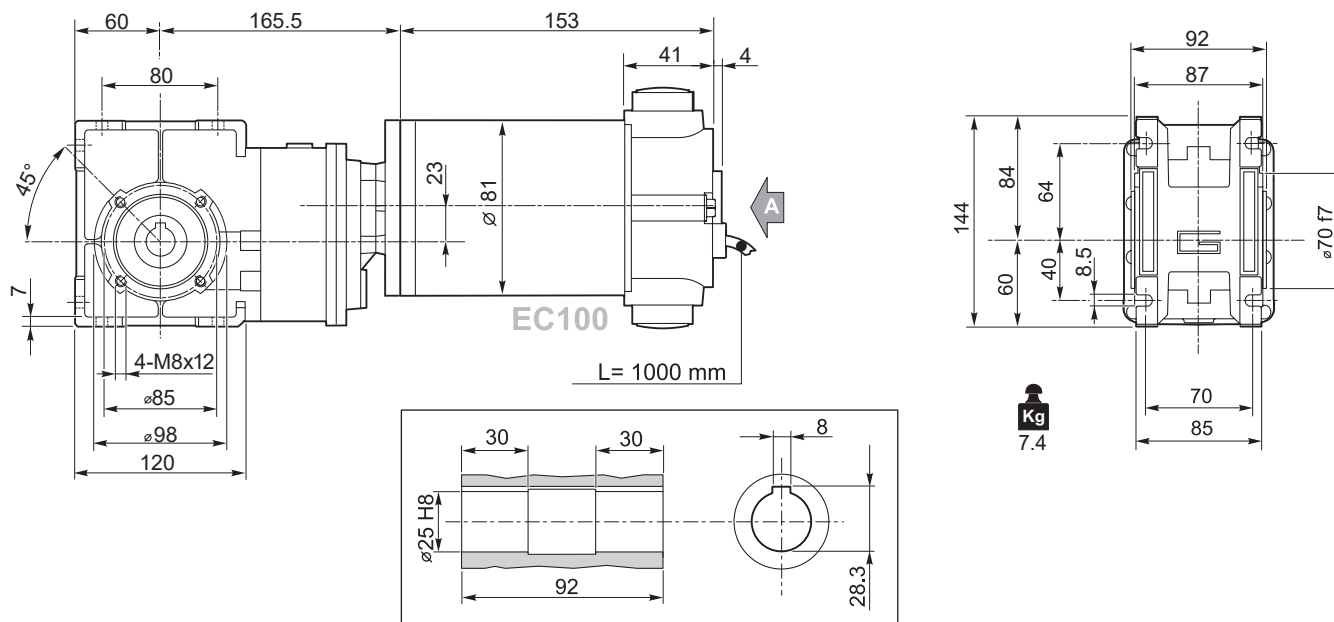

ECMB100/633 U

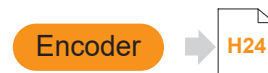
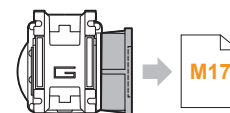
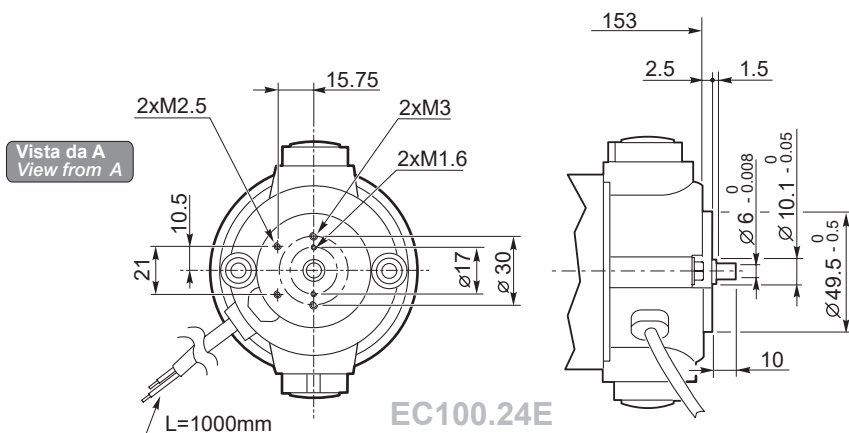
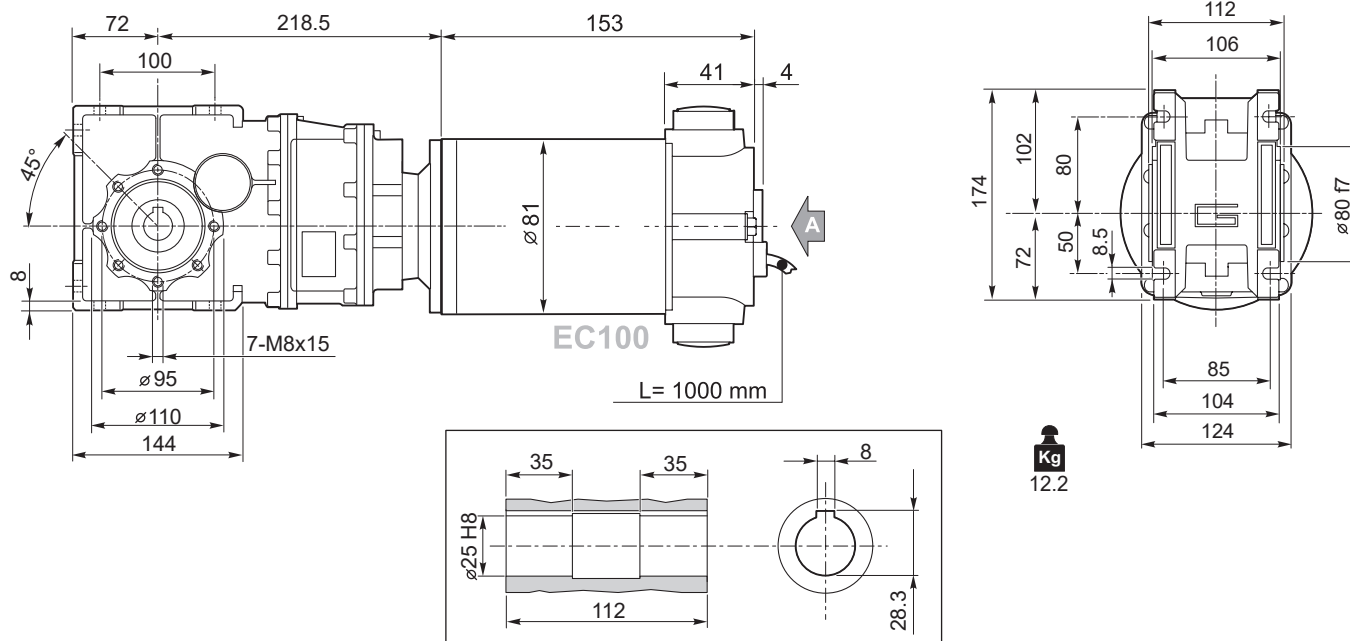

ECMB

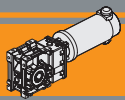

Dimensioni

Dimensions

ECMB180/402 U

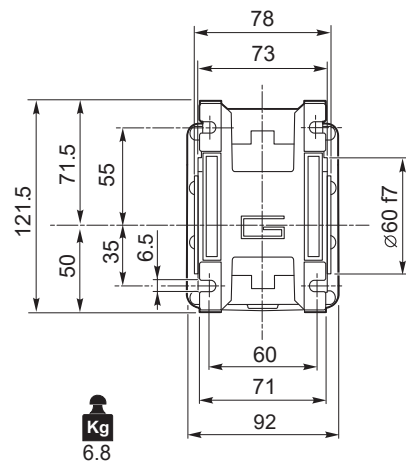
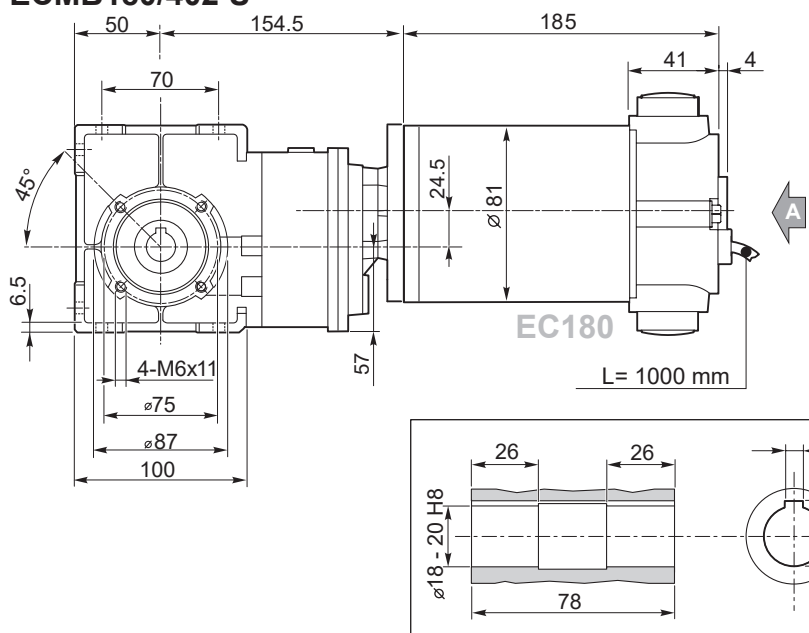

ECMB180/502 U

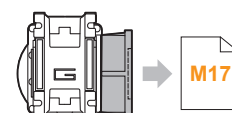
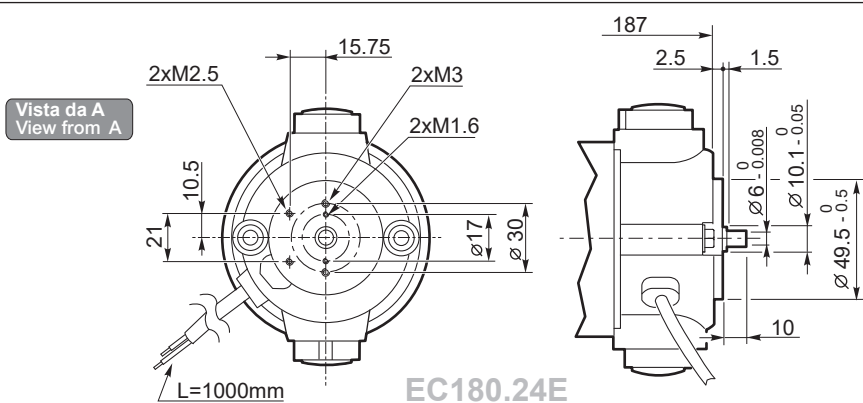
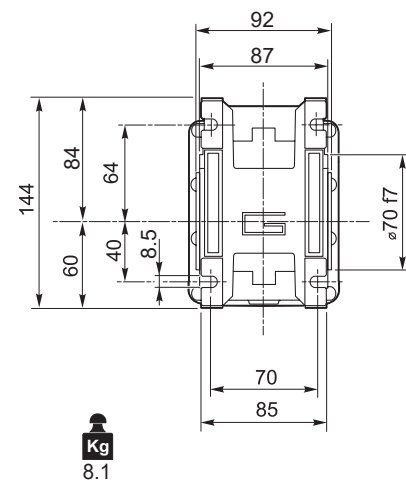
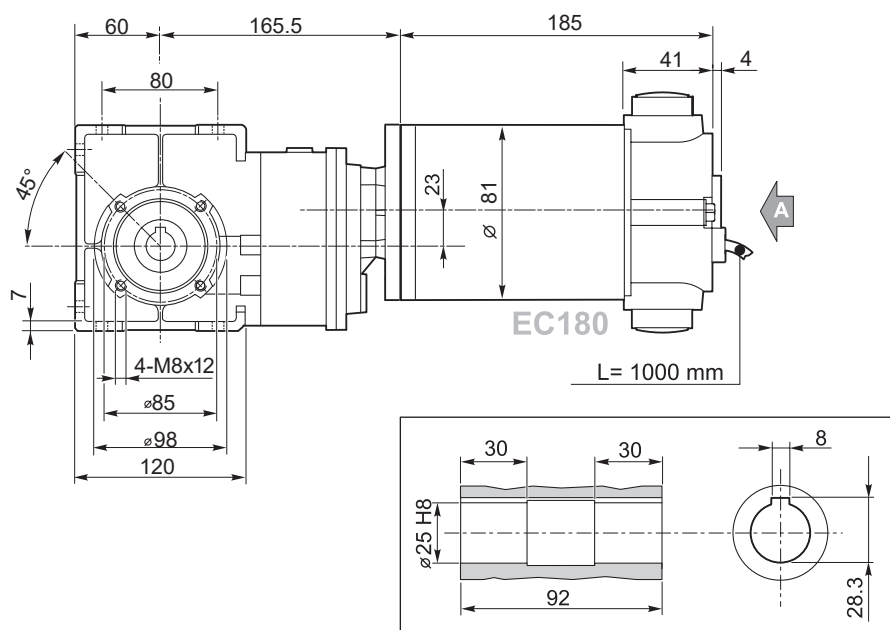

M17



Freno / Brake

H23

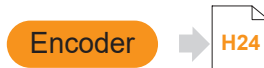

Encoder

H24



Motori / Motors IP66

I6

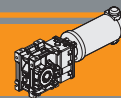

Dimensioni

Dimensions

ECMB180/633 U

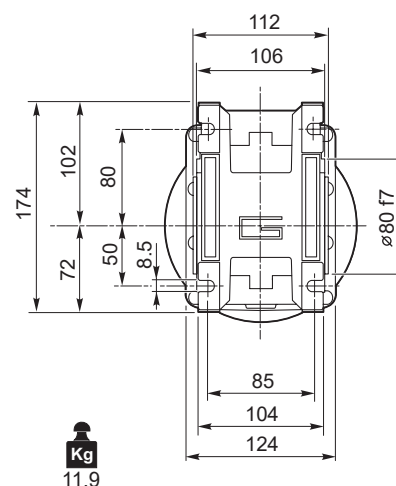
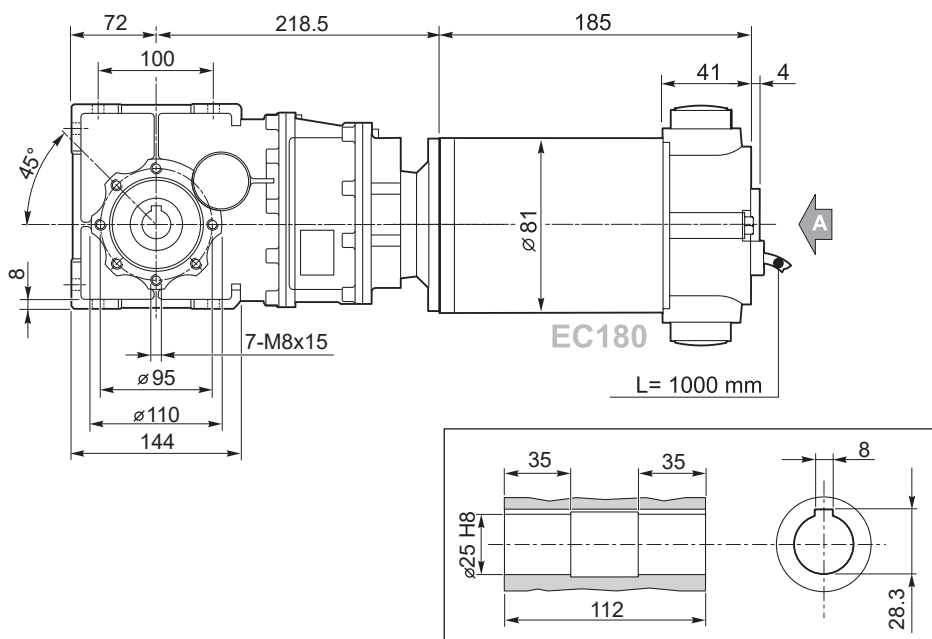

Vista da A
View from A

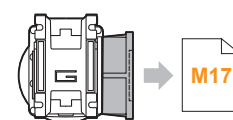
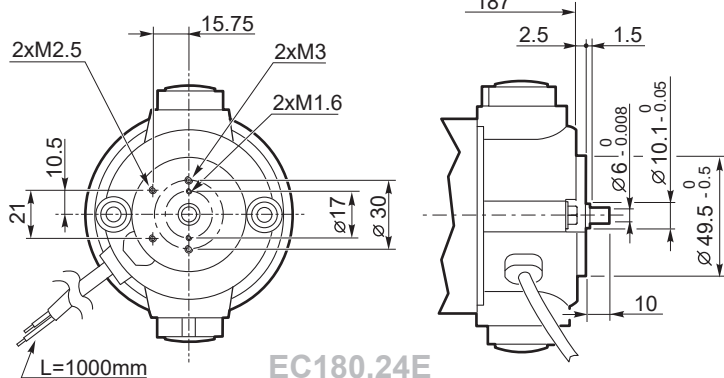

ECMB

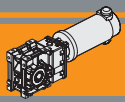

Dimensioni

Dimensions

ECMB250/402 U

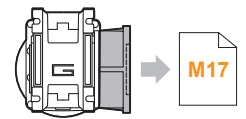
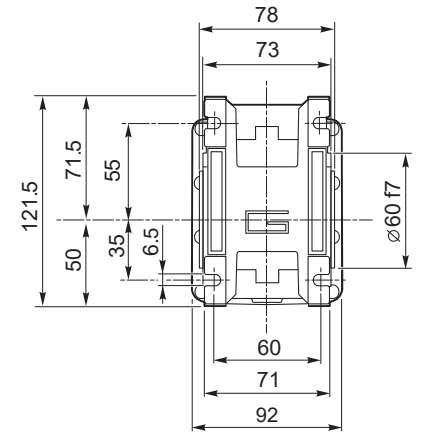
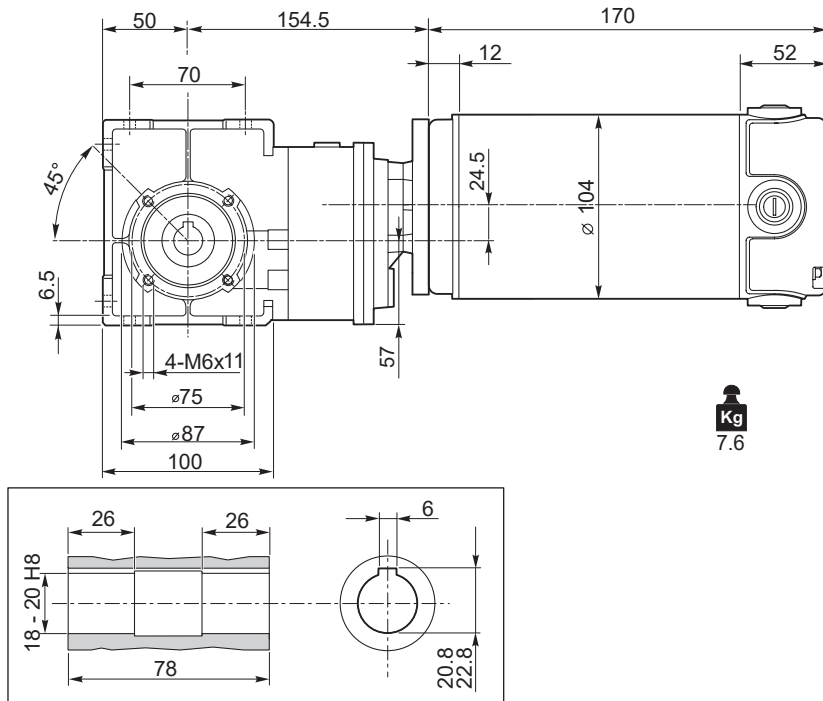

ECMB250/502 U

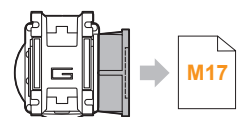
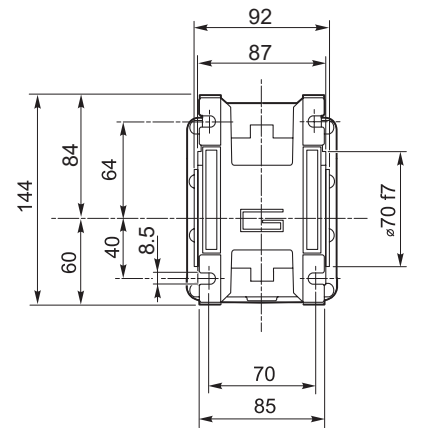
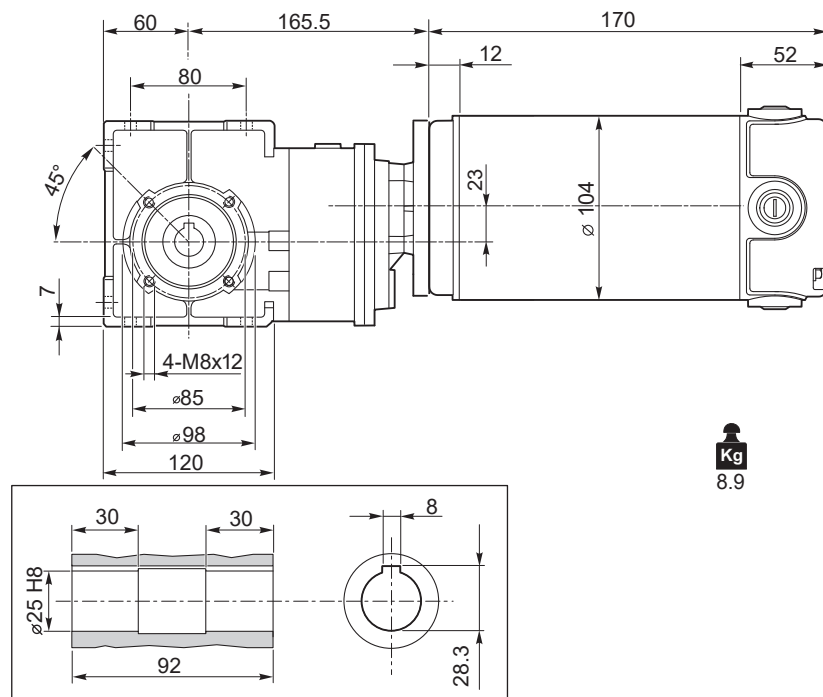

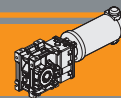

Dimensioni

Dimensions

ECMB250/633 U

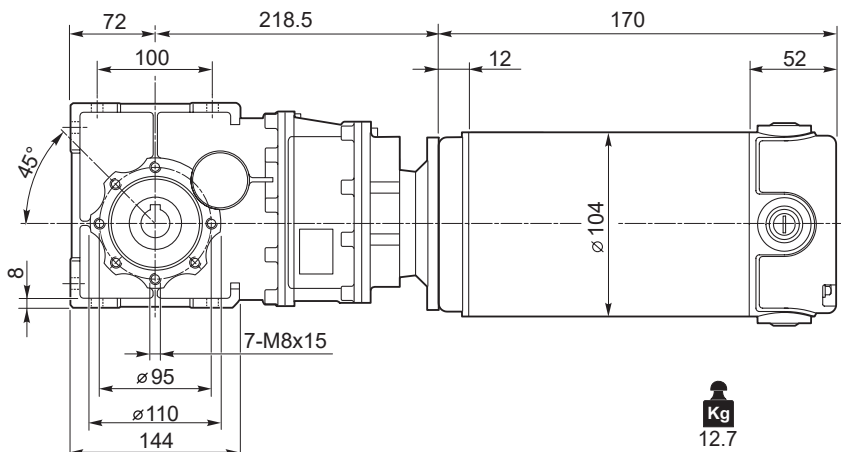

Kg
12.7

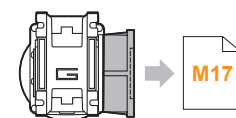
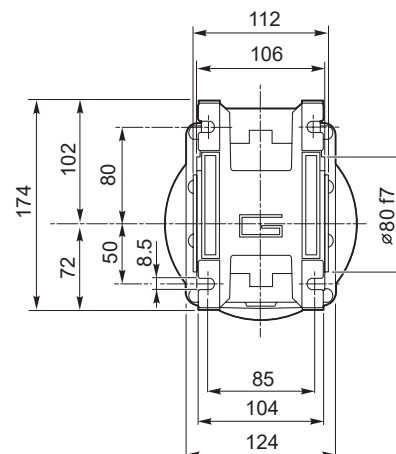

Motori / Motors IP66

ECMB350/402 U

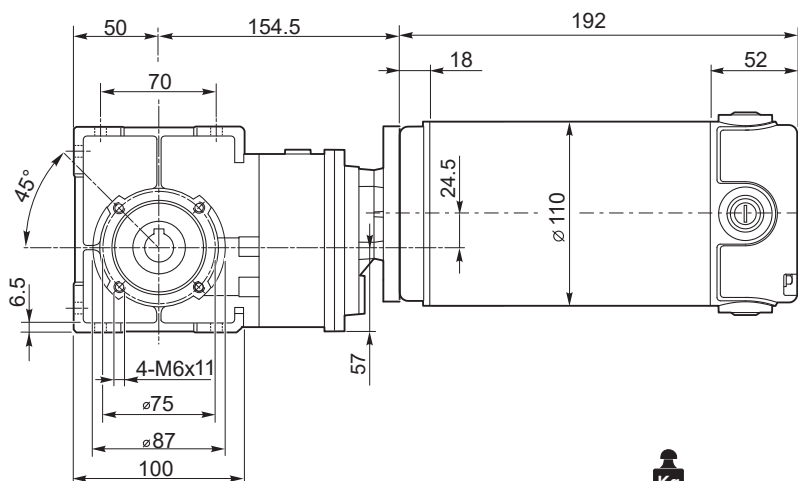

Kg
8.7

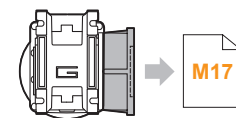
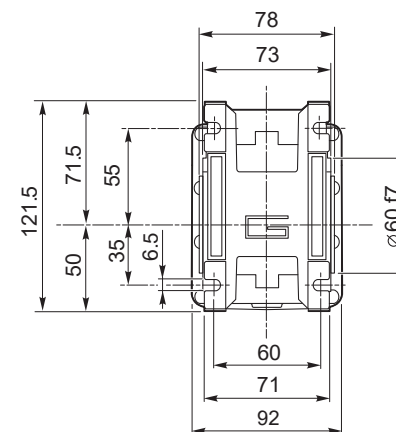

Freno / Brake

Motori / Motors IP66

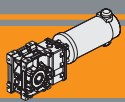

Dimensioni

Dimensions

ECMB350/502 U

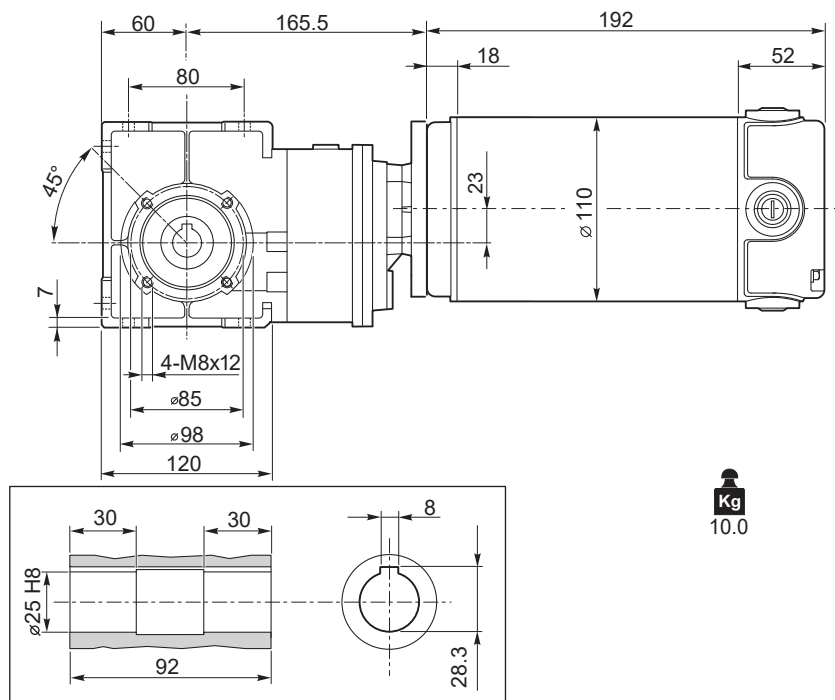

Kg
10.0

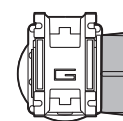
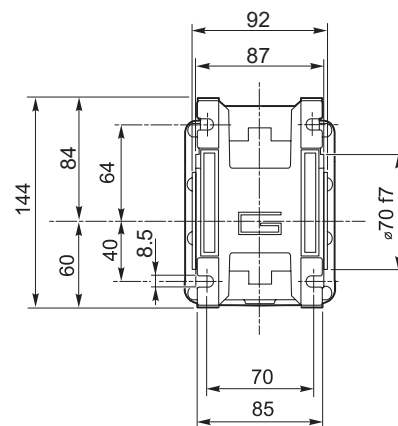

M17

Freno / Brake

H23

Motori / Motors IP66

I10

ECMB350/633 U

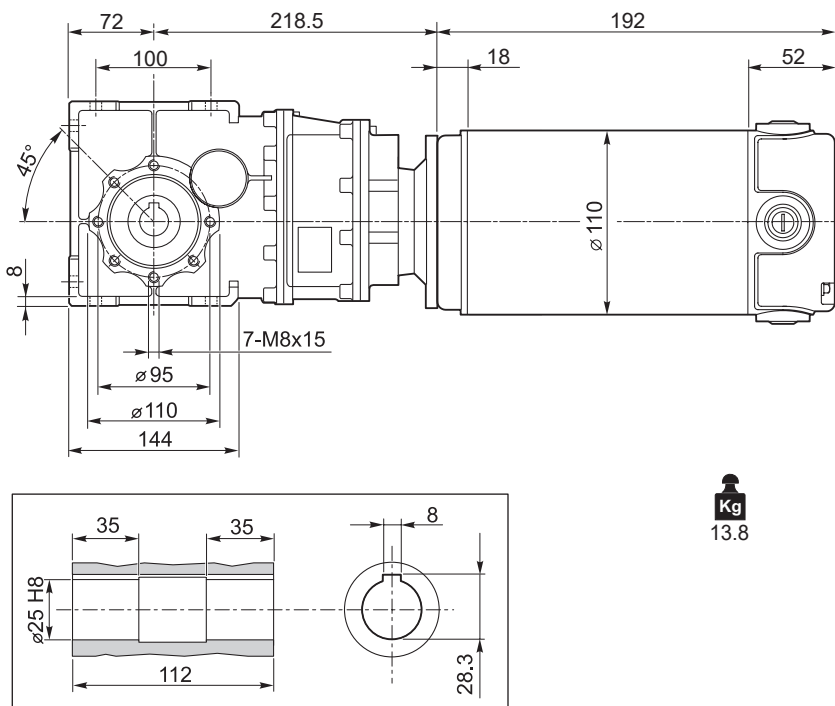

Kg
13.8

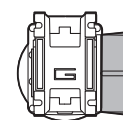
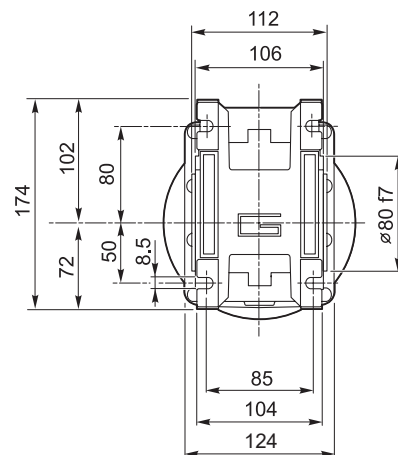

M17

Freno / Brake

H23

Motori / Motors IP66

I10

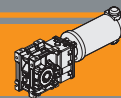

Dimensioni

Dimensions

ECMB350/903 U

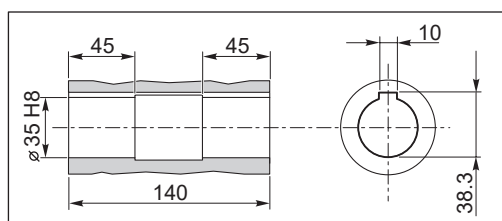
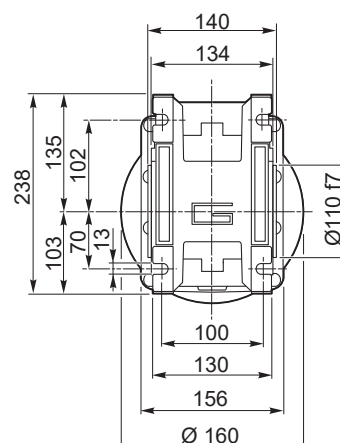
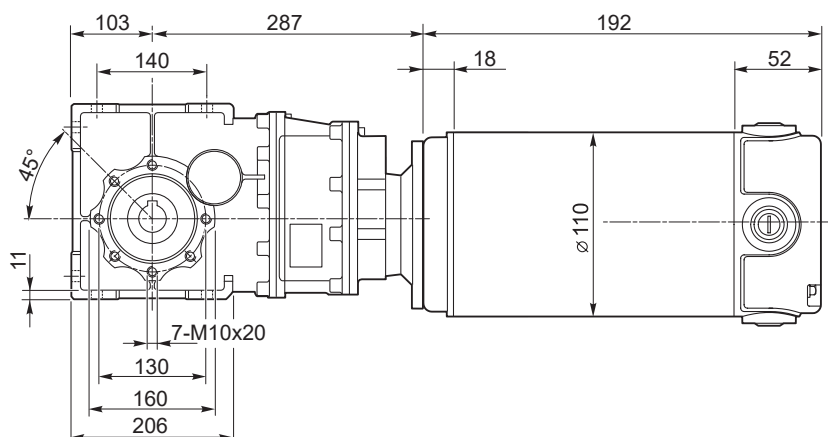

Kg
23.4

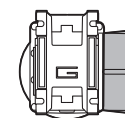

M17

Freno / Brake

H23

ECMB600/402 U

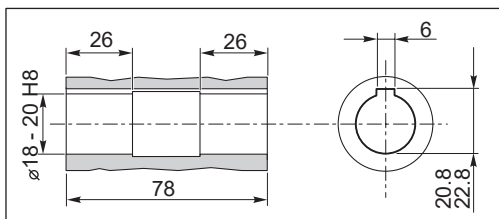
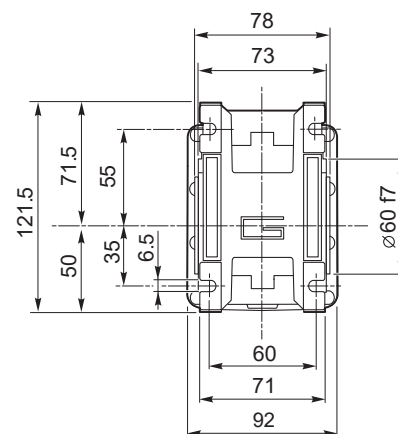
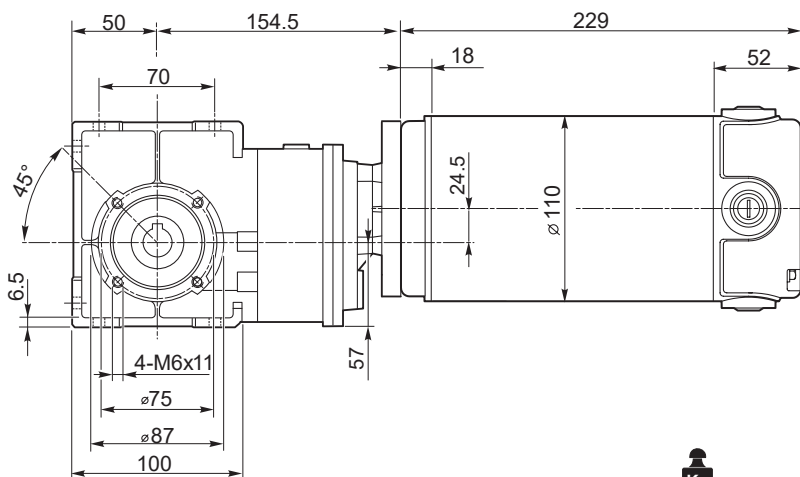

Kg
10.5

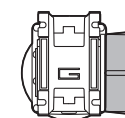

M17

Freno / Brake

H23

Motori / Motors IP66

I12

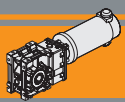

Dimensioni

Dimensions

ECMB600/502 U

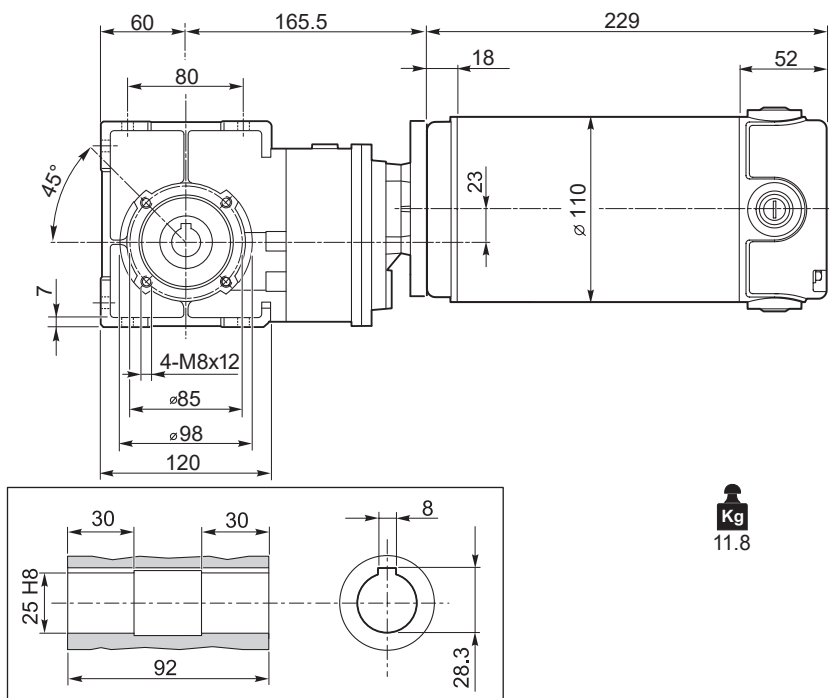

Kg
11.8

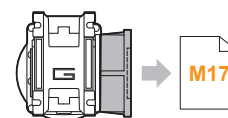
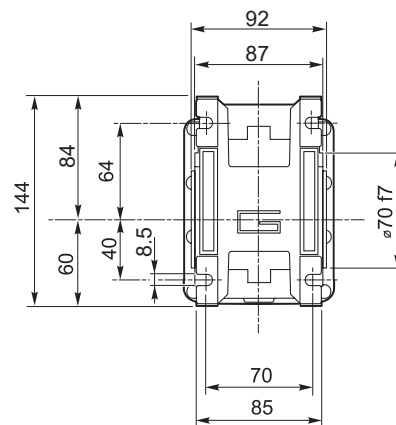

Freno / Brake → **H23**

Motori / Motors IP66 → **I12**

ECMB600/633 U

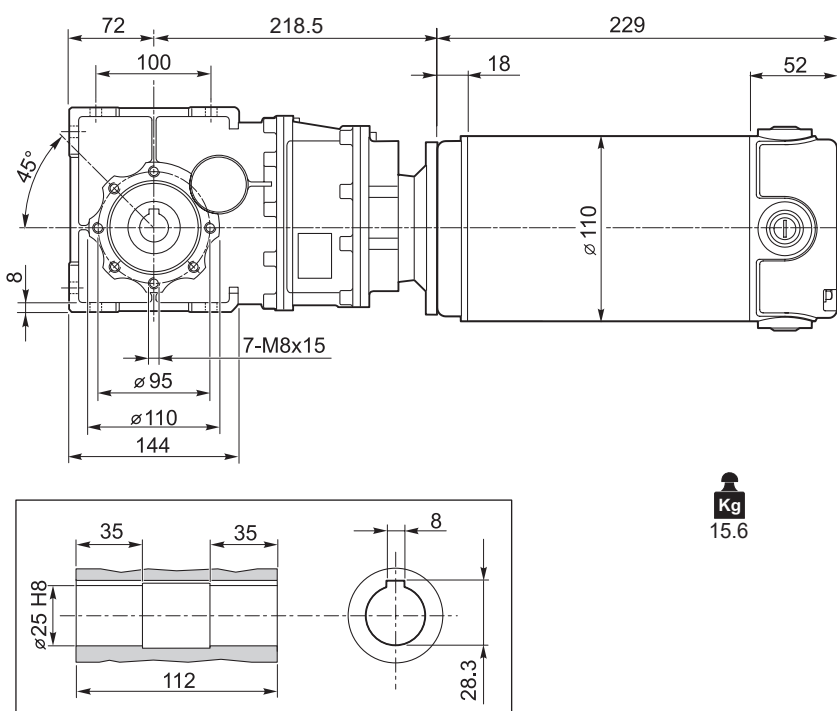

Kg
15.6

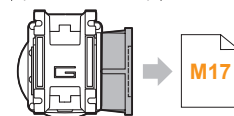
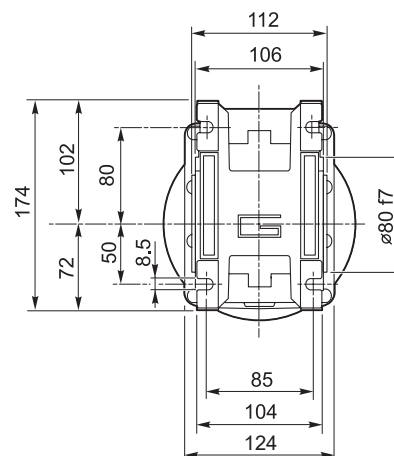

Freno / Brake → **H23**

Motori / Motors IP66 → **I12**

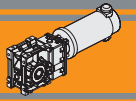

Dimensioni

Dimensions

ECMB600/903 U

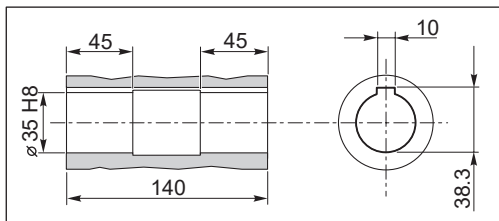
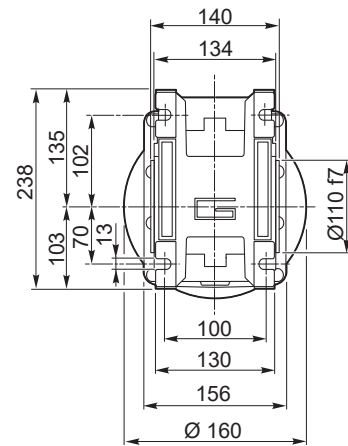
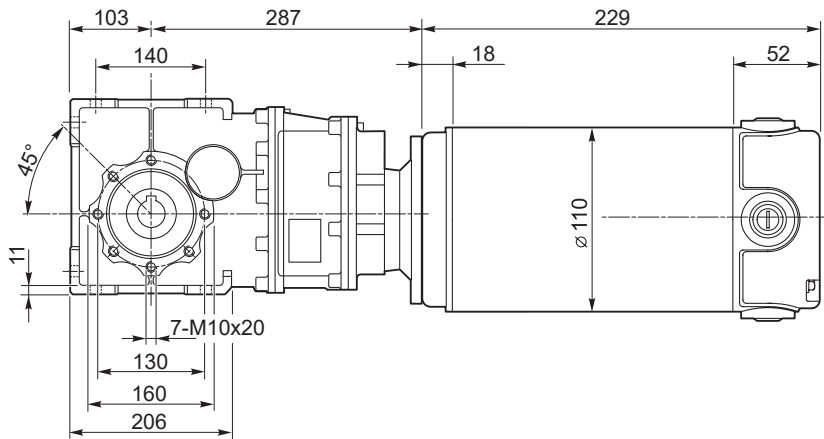

Kg
25.5

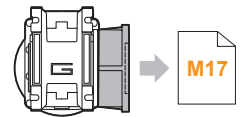

Freno / Brake → **H23**

ECMB.../... F... Flange uscita / Output flanges

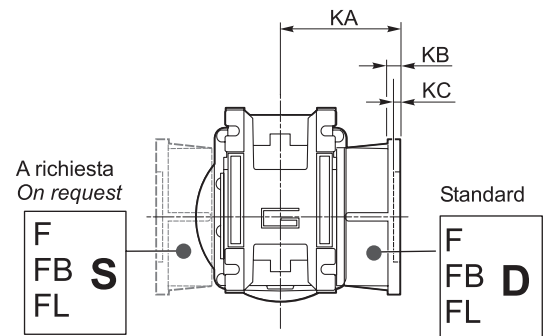
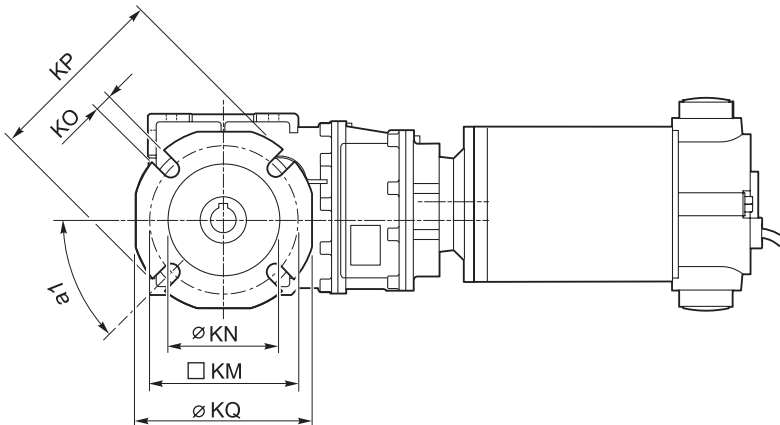

ECMB

CMB	Flange uscita / Output flanges																										
	F									FL									FB								
	a_1	KA	KB	KC	KM	KN H8	KO	KP	KQ	a_1	KA	KB	KC	KM	KN H8	KO	KP	KQ	a_1	KA	KB	KC	KM	KN H8	KO	KP	KQ
402	45°	67	7.5	4.5	80-95	60	9	110	95	45°	97	7.5	4.5	80-95	60	9	110	95	45°	80	8.5	5	115-125	95	9.5	140	112
502	45°	90	9	5	90-110	70	11	125	110	45°	120	9	5	90-110	70	11	125	110	45°	89	9	5	130-145	110	9.5	160	132
633	45°	82	10	6	150 - 160	115	11	180	142	45°	112	10	8	150 - 160	115	11	180	142	45°	98	11	5	165	130	11	200	160
933	45°	111	13	6	175-188	152	14	210	200	-									-								

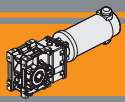

Accessori

Accessories

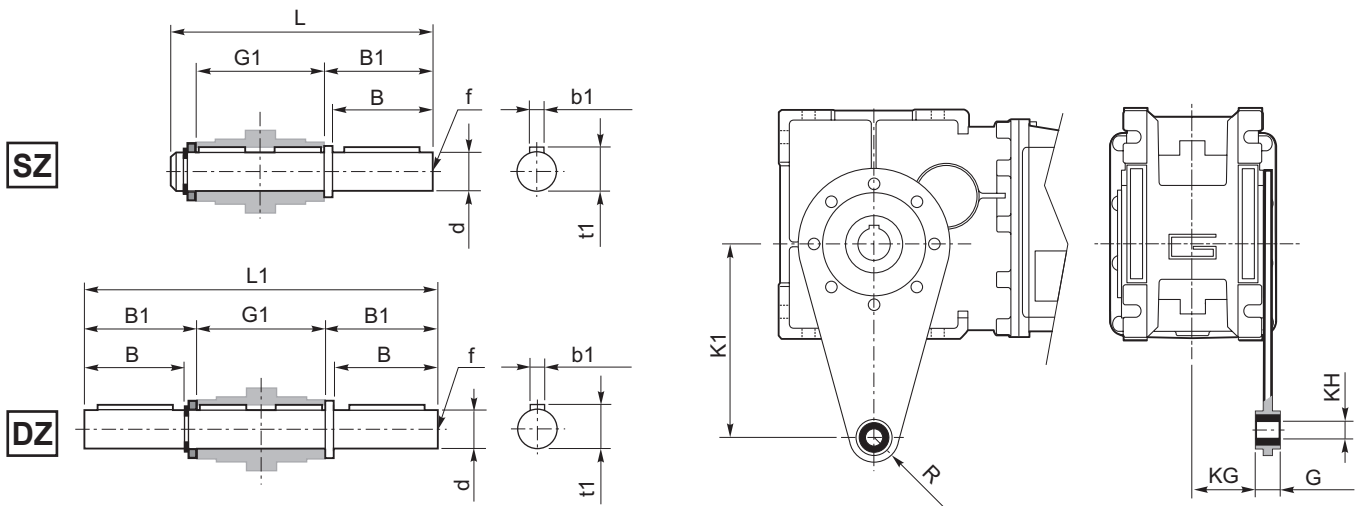

Albero lento / Output shaft

CMB CMBIS	d h7	B	B1	G1	L	L1	f	b1	t1
402	18	40	43	78	128	164	M6	6	20.5
502	25	50	53.5	92	153	199	M10	8	28
633	25	50	53.5	112	173	219	M10	8	28
903	35	80	84.5	140	234	309	M12	10	38

Braccio di reazione / Torque arm

CMB CMBIS	K1	G	KG	KH	R
402	100	14	31	10	18
502	100	14	38	10	18
633	150	14	47.5	10	18
903	200	25	56.5	20	30

SC - Safety cover

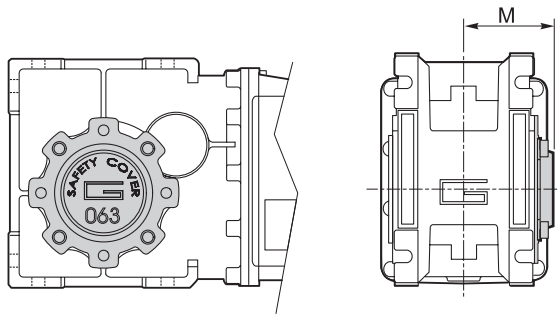

CMB CMBIS	M
402	54.5
502	62.5
633	73
903	94



Ferrite

Motoriduttori CC pendolari
DC helical parallel gearmotors



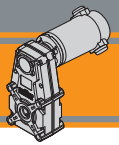

Indice	Index	Pag. Page
Caratteristiche tecniche	<i>Technical features</i>	N2
Designazione	<i>Classification</i>	N2
Sensi di rotazione	<i>Direction of rotation</i>	N3
Simbologia	<i>Symbols</i>	N3
Lubrificazione	<i>Lubrication</i>	N3
Carichi radiali	<i>Radial loads</i>	N4
Dati tecnici	<i>Technical data</i>	N5
Motori applicabili	<i>Motor adapters</i>	N6
Dimensioni	<i>Dimensions</i>	N7

Questa sezione annulla e sostituisce ogni precedente edizione o revisione. Qualora questa sezione non Vi sia giunta in distribuzione controllata, l'aggiornamento dei dati ivi contenuto non è assicurato. **In tal caso la versione più aggiornata è disponibile sul nostro sito internet www.transtecno.com**

This section replaces any previous edition and revision. If you obtained this catalogue other than through controlled distribution channels, the most up to date content is not guaranteed. In this case the latest version is available on our web site www.transtecno.com

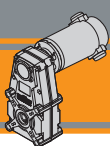

Caratteristiche tecniche

Technical features

I motoriduttori CC pendolari a magneti permanenti in ferrite ECFT hanno le seguenti caratteristiche principali:

ECFT ferrite permanent magnets DC helical parallel gearmotors range has the following main features:

- Alimentazione in bassa tensione 12/24 Vcc
- Possibilità di montaggio encoder e freno
- Potenze motore disponibili da 100 a 800W S2
- Magneti in ferrite
- Carcasa pressofusione di alluminio
- Lubrificazione permanente con olio sintetico.
- Ingranaggi cilindrici a denti elicoidali.

- Low voltage power supply 12/24 Vdc
- Suitable for encoder and brake assembly
- Motor power ratings available from 100 to 800W S2
- Ferrite magnets
- Die-cast aluminum housings
- Permanent synthetic oil long-life lubrication.
- helical gears.

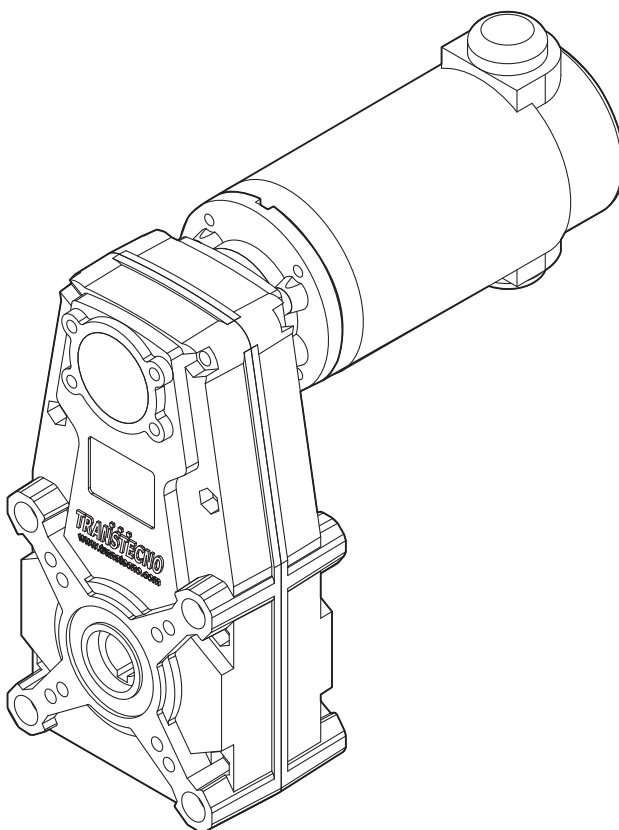

Designazione

Classification

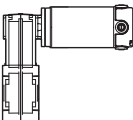
MOTORIDUTTORE / GEARMOTORS							U	60.63	O20	B5
ECFT	180/146						U	60.63	O20	B5
Tipo Type	Grandezza Size						Versione Version	Rapporto Ratio	Albero cavo uscita Hollow output shaft	Versione motore Motor version
	070/105/3	100/105/3	180/105/3	250/146	350/146	600/146	U...	vedi tabelle see tables	vedi tabelle see tables	120 240 12E 24E
	070/105/4	100/146	180/146	250/196	350/196	600/196				
	070/146									

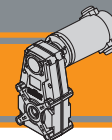

Sensi di rotazione

Direction of rotation

FT105/3
FT146
FT196

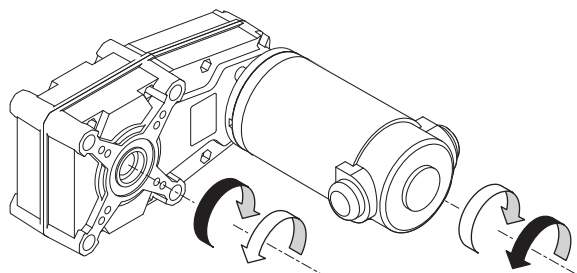
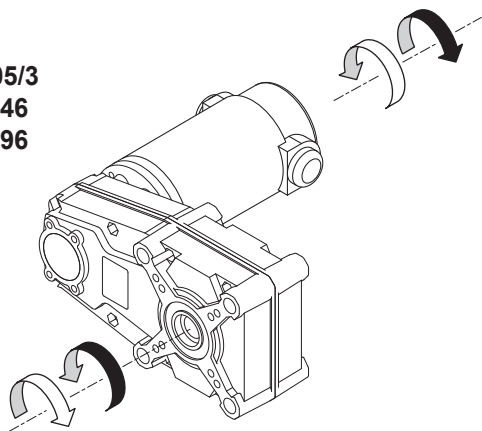

FT105/4

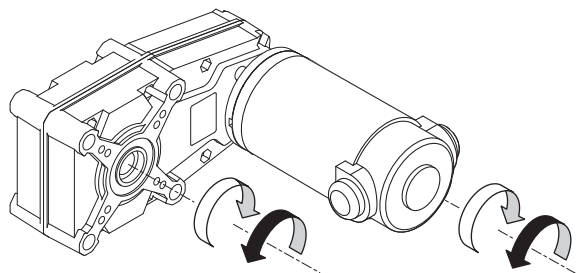
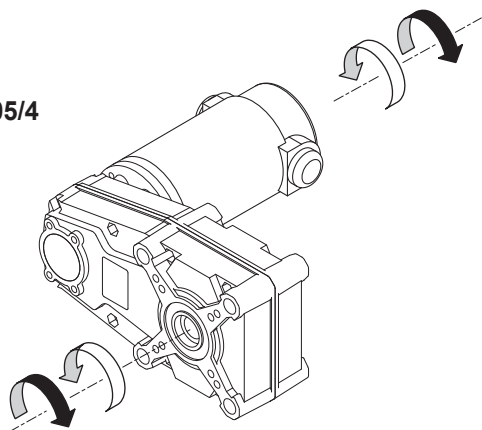

Simbologia

Symbols

n_1	[min^{-1}]	Velocità in ingresso / <i>Input speed</i>
n_2	[min^{-1}]	Velocità in uscita / <i>Output speed</i>
i		Rapporto di riduzione / <i>Ratio</i>
P_1	[kW]	Potenza in entrata / <i>Input power</i>
M_2	[Nm]	Coppia nominale in uscita in funzione di P_1 / <i>Output torque referred to P_1</i>
P_{n1}	[kW]	Potenza nominale in entrata / <i>Nominal input power</i>
M_{n2}	[Nm]	Coppia nominale in uscita in funzione di P_{n1} / <i>Nominal output torque referred to P_{n1}</i>
sf		Fattore di servizio / <i>Service factor</i>
R_2	[N]	Carico radiale ammissibile in uscita / <i>Permitted output radial load</i>
A_2	[N]	Carico assiale ammissibile in uscita / <i>Permitted output axial load</i>

Lubrificazione

Lubrication

Tutti i motoriduttori sono forniti completi di lubrificante sintetico viscosità 320, pertanto possono essere installati in qualunque posizione di montaggio e non necessitano di manutenzione.

Permanent synthetic oil long-life lubrication (viscosity grade 320) makes it possible to use the gearmotors in all mounting positions; for this reason they can be installed in any assembly position and do not require maintenance.

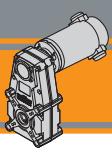

Carichi radiali

Radial loads

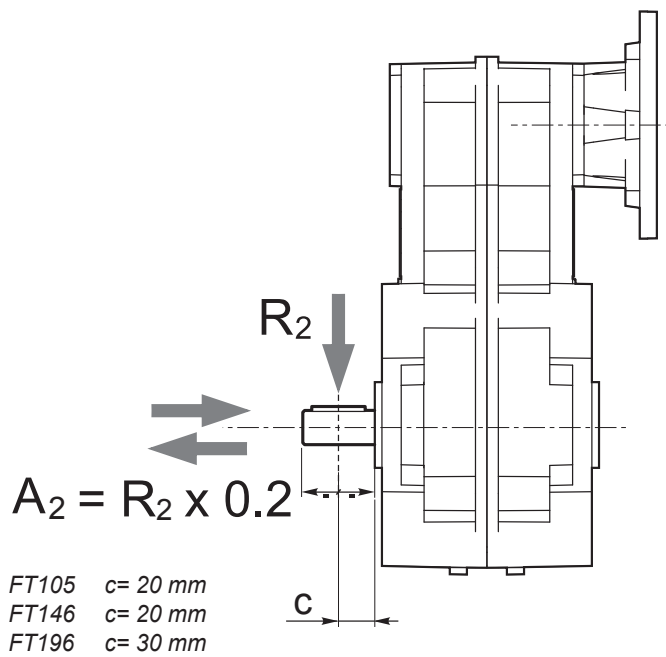

n_2 [min ⁻¹]	R_2 [N]		
	FT105	FT146	FT196
70	1500	2500	3500
40	1700	2700	4000
30	1850	2850	4600
20	2000	3000	5500
10	2000	3000	7000
5	2000	3000	7000

Quando il carico radiale risultante non è applicato sulla mezza-
ria dell'albero occorre calcolare quello effettivo con la seguente
formula:

When the resulting radial load is not applied on the centre line
of the shaft it is necessary to calculate the effective load with the
following formula:

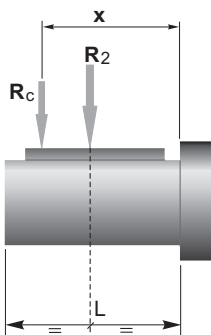

	FT105	FT146	FT196
a	82	82,5	132
b	62	62,5	102
R_{2MAX}	2000	3000	7000

$$R_c = \frac{R_2 \cdot a}{(b+x)} \leq R_{2MAX}$$

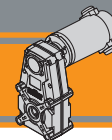

$$R \leq R_c$$

a, b = valori riportati nella tabella
a, b = values given in the table



Dati tecnici

Technical data

P_1 [W]	n_2 [min ⁻¹]	M_2 [Nm]	sf	i		Versione motore Motor version	P_1 [W]	n_2 [min ⁻¹]	M_2 [Nm]	sf	i		Versione motore Motor version
100							140						
(3000 min ⁻¹)	146	6	5.1	20.57	070/105/3	12E/24E	(3000 min ⁻¹)	31	40	2.1	95.61	100/146	120/240/24E
	90	10	3.9	33.32				26	48	1.8	113.40		
	68	13	3.8	44.36				22	56	1.5	133.45		
	55	16	3.1	54.87				20	63	1.4	150.18		
	42	21	2.4	71.84				19	67	1.4	160.43		
	39	23	2.2	77.07				17	75	1.2	178.83		
	34	27	1.9	88.87				13	94	1.0	223.92		
	24	37	1.4	124.81				13	99	0.9	236.83		
	17	54	0.9	181.35				10	126	0.7	300.07		
	13	67	0.8	224.32									
	9.5	86	0.6	315.05									
	8.1	86	0.6	368.19	070/105/4	12E/24E	(3000 min ⁻¹)	146	15	2.0	20.57	180/105/3	120/240
	5.6	86	0.6	534.98				90	25	1.6	33.32		
	4.5	86	0.6	661.76				68	33	1.5	44.36		
	3.2	86	0.6	929.40				55	41	1.2	54.87		
	160	6	11.1	18.75	070/146	12E/24E		42	54	0.9	71.84		
	115	8	8.0	26.17				39	58	0.9	77.07		
	106	8	7.4	28.26				34	66	0.8	88.87		
	86	10	7.4	35.07				160	14	4.4	18.75	180/146	120/240/24E
	76	12	6.6	39.44				115	20	3.2	26.17		
	65	14	5.6	46.44				106	21	3.0	28.26		
	57	16	4.9	52.86				86	26	3.0	35.07		
	49	18	4.7	60.63				76	30	2.6	39.44		
	43	21	4.1	70.00				65	35	2.2	46.44		
	35	25	3.4	84.63				57	40	2.0	52.86		
	31	29	3.0	95.61				49	45	1.9	60.63		
	26	34	2.5	113.40				43	52	1.6	70.00		
	22	40	2.1	133.45				35	63	1.4	84.63		
	20	45	1.9	150.18				31	72	1.2	95.61		
	19	48	1.9	160.43				26	85	1.0	113.40		
	17	54	1.7	178.83				22	100	0.9	133.45		
	13	67	1.4	223.92		20	112	0.8	150.18				
	13	71	1.3	236.83		19	120	0.8	160.43				
	10	90	1.0	300.07		17	134	0.7	178.83				
	7.5	119	0.8	397.38									
140							350						
(3000 min ⁻¹)	146	9	3.6	20.57	100/105/3	120/240/24E	(3000 min ⁻¹)	160	20	3.2	18.75	250/146	120/240
	90	14	2.8	33.32				115	27	2.3	26.17		
	68	19	2.7	44.36				106	30	2.1	28.26		
	55	23	2.2	54.87				86	37	2.1	35.07		
	42	30	1.7	71.84				76	41	1.9	39.44		
	39	32	1.6	77.07				65	49	1.6	46.44		
	34	37	1.4	88.87				57	55	1.4	52.86		
	24	52	1.0	124.81				49	64	1.4	60.63		
	16.5	76	0.7	181.35				43	73	1.2	70.00		
								35	89	1.0	84.63		
	160	8	7.9	18.75	100/146	120/240/24E		31	100	0.9	95.61		
	115	11	5.7	26.17				26	119	0.7	113.40		
	106	12	5.3	28.26									
	86	15	5.3	35.07									
	76	17	4.7	39.44									
	65	19	4.0	46.44									
	57	22	3.5	52.86									
	49	25	3.4	60.63									
	43	29	2.9	70.00									
	35	35	2.4	84.63									

NOTA
Verificare sempre che la coppia M2 utilizzata non ecceda il valore indicato nelle caselle in grigio

NOTE
Please check that the output torque M2 does not exceed the value in the grey areas

NOTA: per servizio continuo o altamente intermittente, contattare il servizio tecnico

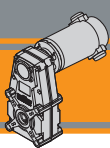

NOTE: for continuous or highly intermittent duty, please contact our technical service

ECFT



Dati tecnici

Technical data

P_1 [W]	n_2 [min ⁻¹]	M_2 [Nm]	sf	i		Versione motore Motor version	P_1 [W]	n_2 [min ⁻¹]	M_2 [Nm]	sf	i		Versione motore Motor version			
350							800									
(3000 min ⁻¹)	147	21	12.8	20.41	250/196	120/240	(3000 min ⁻¹)	160	45	1.4	18.75	600/146	120/240			
	86	36	8.6	34.81			115	63	1.0	26.17						
	70	45	7.9	42.61			106	68	0.9	28.26						
	51	62	6.3	59.36			86	84	0.9	35.07						
	41	76	5.6	72.68			76	94	0.8	39.44						
	32	97	4.4	92.82			65	111	0.7	46.44						
	24	130	3.3	123.95			147	49	5.6	20.41						
	19	165	2.6	158.02			86	83	3.7	34.81						
	15	211	2.0	201.80	70	102	3.4	42.61								
	11	282	1.5	269.47	51	142	2.7	59.36								
					41	174	2.5	72.68								
					32	222	1.9	92.82								
					24	297	1.4	123.95								
					19	378	1.1	158.02								
					15	483	0.9	201.80								
500																
(3000 min ⁻¹)	160	28	2.2	18.75	350/146	120/240										
	115	39	1.6	26.17												
	106	42	1.5	28.26												
	86	52	1.5	35.07												
	76	59	1.3	39.44												
	65	69	1.1	46.44												
	57	79	1.0	52.86												
	49	91	0.9	60.63												
	43	105	0.8	70.00												
	147	31	8.9	20.41			350/196	120/240								
	86	52	6.0	34.81												
	70	64	5.5	42.61												
	51	89	4.4	59.36												
	41	109	3.9	72.68												
	32	139	3.1	92.82												
	24	185	2.3	123.95												
	19	236	1.8	158.02												
	15	302	1.4	201.80												
	11	403	1.1	269.47												

NOTA: per servizio continuo o altamente intermittente, contattare il servizio tecnico

NOTE: for continuous or highly intermittent duty, please contact our technical service

Motori applicabili

Motor adapters

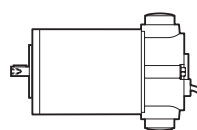

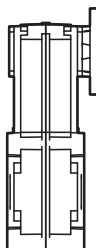
		EC						
		070.12E 070.24E	100.120 100.240 100.24E	180.120 180.240	180.24E	250.120 250.240	350.120 350.240	600.120 600.240
	105/3	20.57 - 315.05	20.57 - 315.05	20.57 - 315.05				
	105/4	368.19 - 929.4	368.19 - 929.4	368.19 - 929.4				
	146	18.75 - 397.38	18.75 - 397.38	18.75 - 397.38	18.75 - 397.38	18.75 - 397.38	18.75 - 397.38	18.75 - 397.38
	196		(*)	(*)	(*)	20.41 - 269.47	20.41 - 269.47	20.41 - 269.47

20.57 - 315.05

Rapporti di riduzione i
Ratio i

(*) Motore applicabile con portaspazzola inclinato di 45°.

Si prega di contattare il nostro servizio tecnico.

(*) Motor assembly with brush holder inclined 45°.

Please contact our technical service.

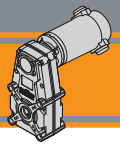

Dimensioni

Dimensions

ECFT 070/105

ECFT 070/105...U

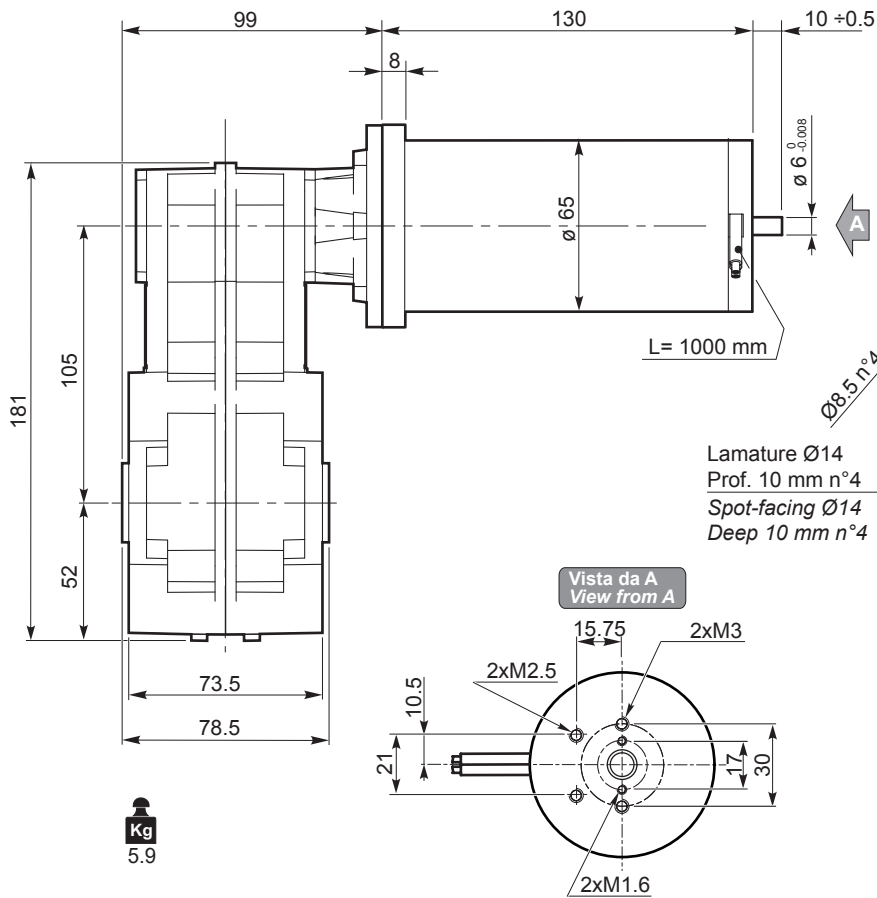

Lamature Ø14
Prof. 10 mm n°4
Spot-facing Ø14
Deep 10 mm n°4

NOTA: Stessi fissaggi da entrambi i lati
NOTE: Same fixing points in both sides

Freno / Brake

H23

Encoder

H24

Motori / Motors IP66

I2

O17

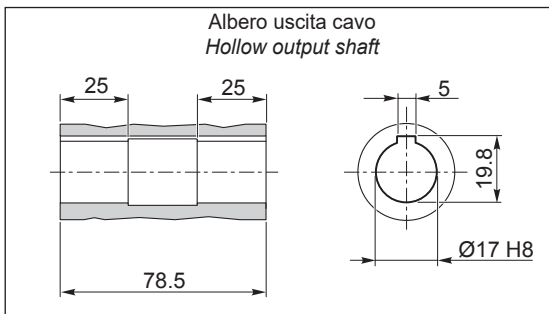

O20

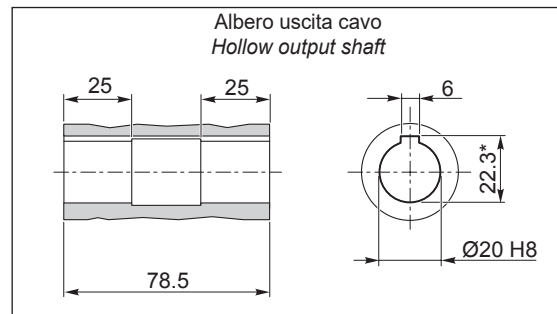

*: Sede linguetta ribassata / Special keyway

ECFT

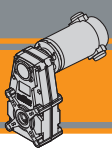

ECFT 100/105

ECFT 100/105...U

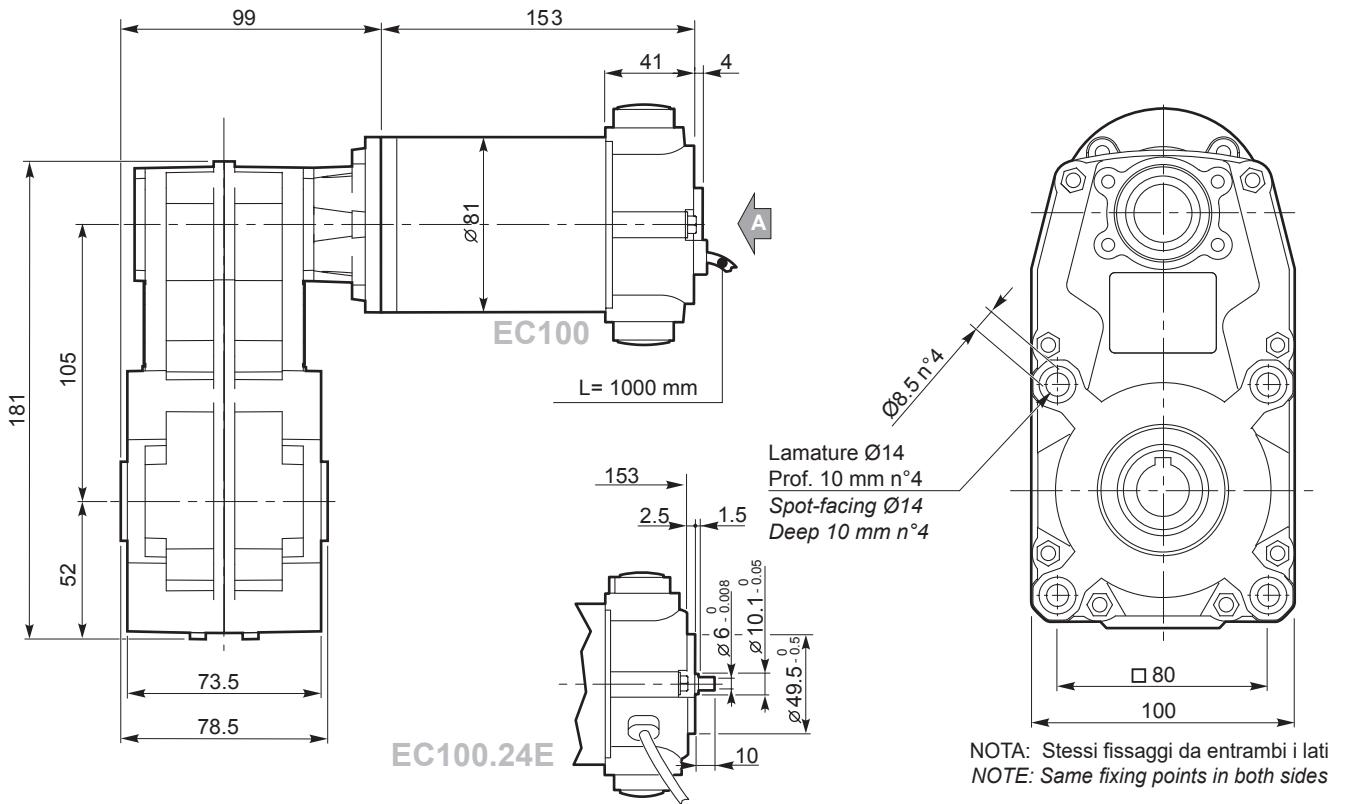

Kg
6.9

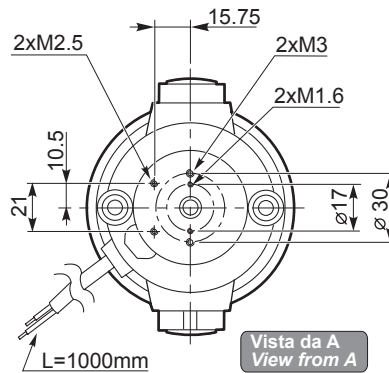

- Freno / Brake → H23
- Encoder → H24
- Motori / Motors IP66 → I4

O17

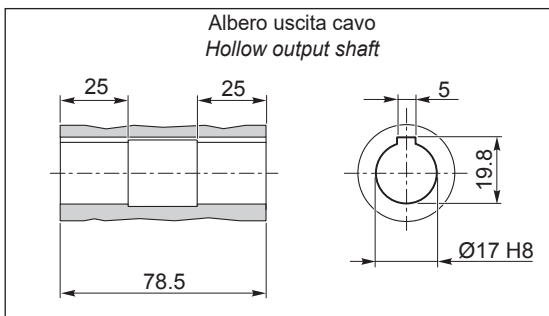

O20

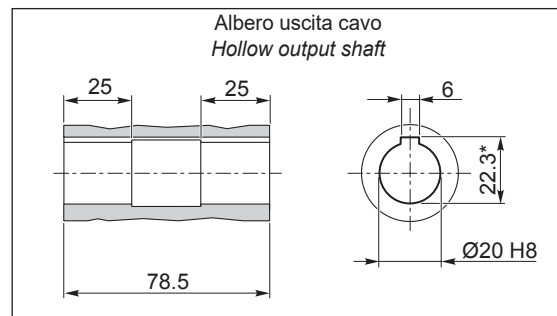

*: Sede linguetta ribassata / Special keyway

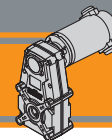

Dimensioni

Dimensions

ECFT 180/105

ECFT 180/105...U

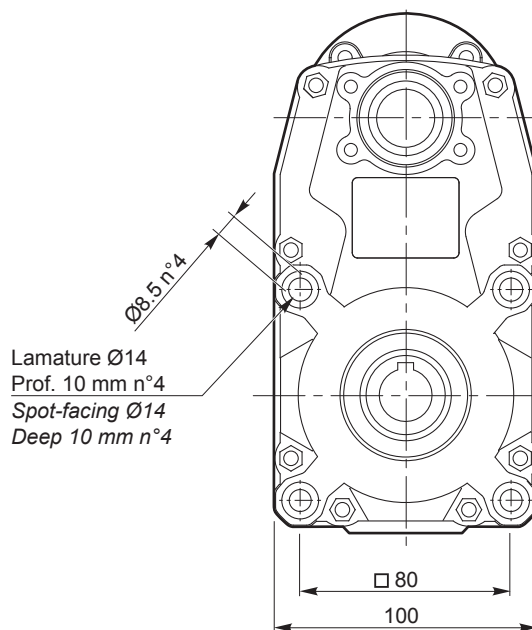
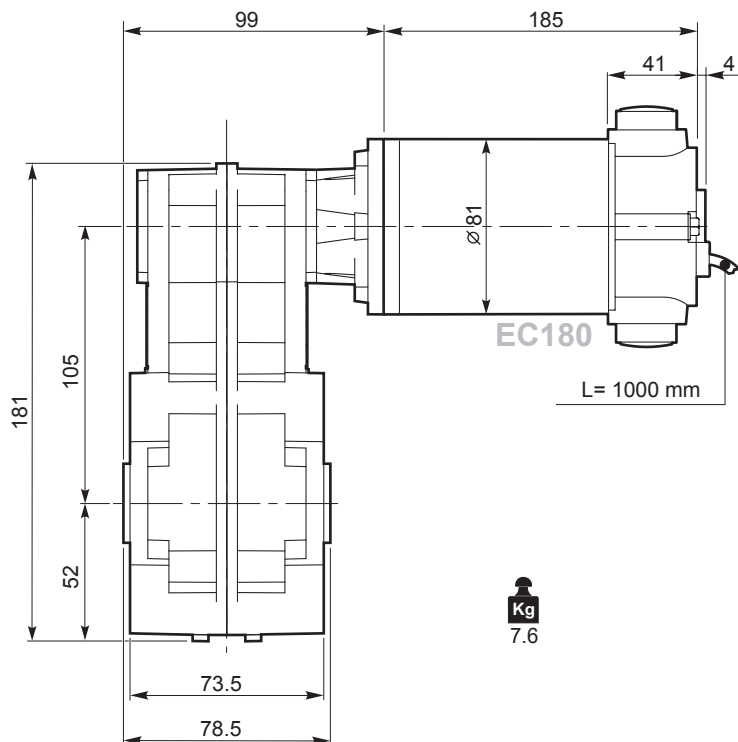

NOTA: Stessi fissaggi da entrambi i lati
NOTE: Same fixing points in both sides

Freno / Brake → H23

Encoder → H24

Motori / Motors IP66 → I6

O17

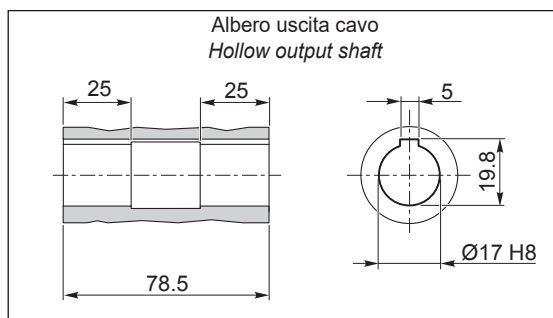

O20

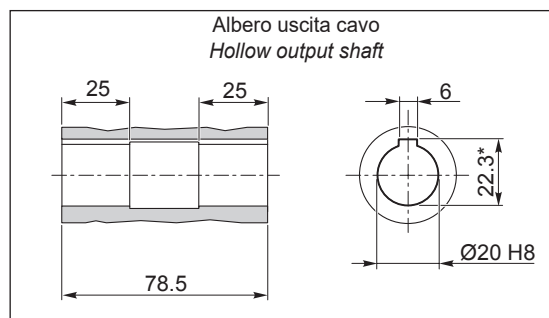

*: Sede linguetta ribassata / Special keyway

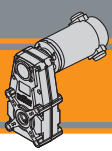

Dimensioni

Dimensions

ECFT 070/146

ECFT 070/146 U

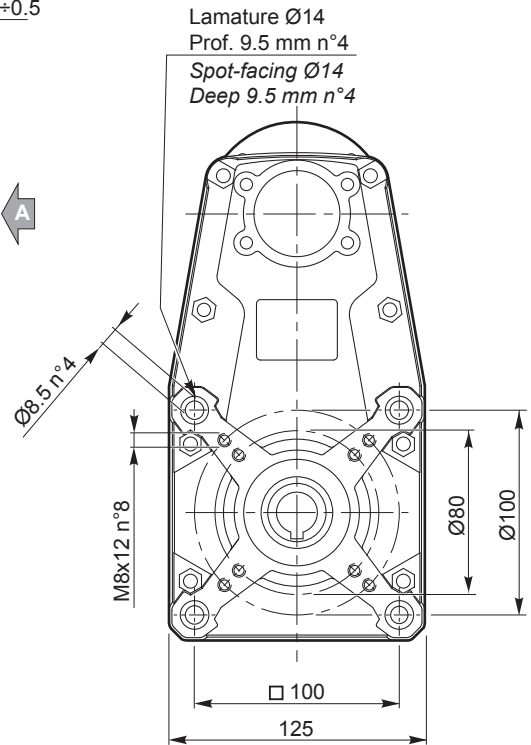
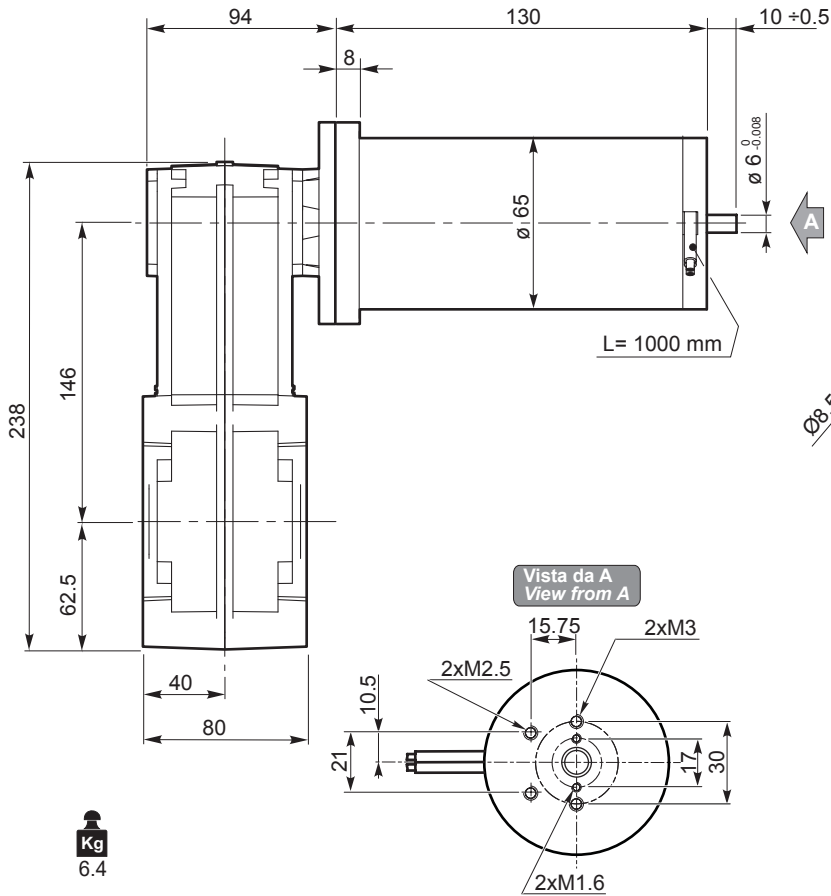

NOTA: Stessi fissaggi da entrambi i lati
NOTE: Same fixing points in both sides

Freno / Brake → H23

Encoder → H24

Motori / Motors IP66 → I2

O20

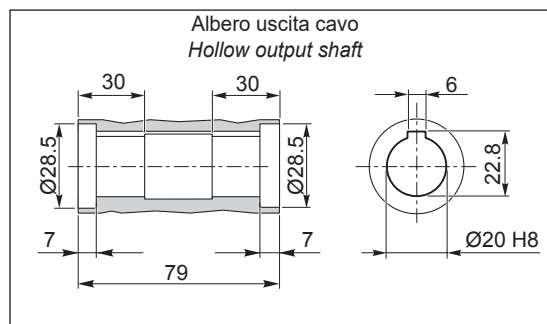

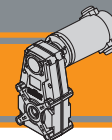

Dimensioni

Dimensions

ECFT 100/146

ECFT 100/146 U

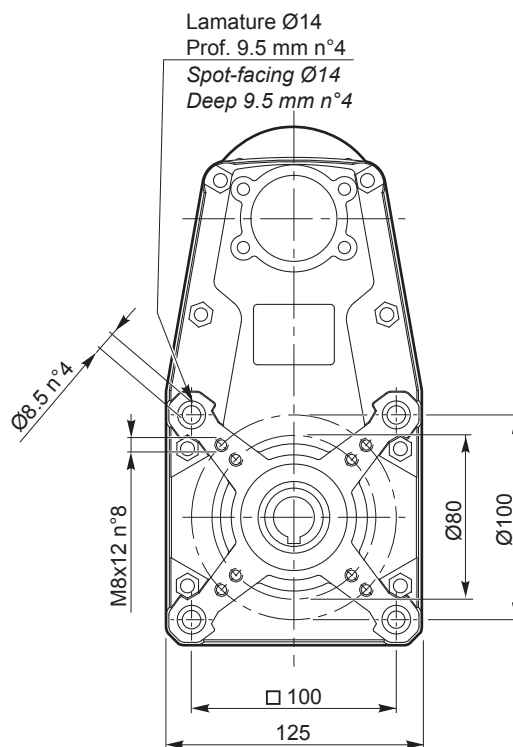
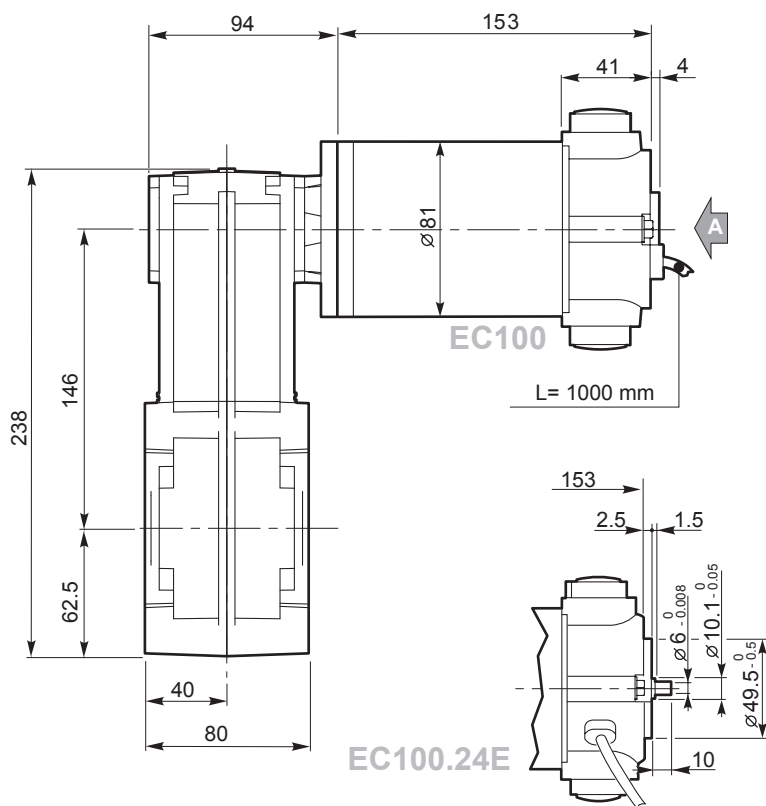

NOTA: Stessi fissaggi da entrambi i lati
NOTE: Same fixing points in both sides

Kg
7.4

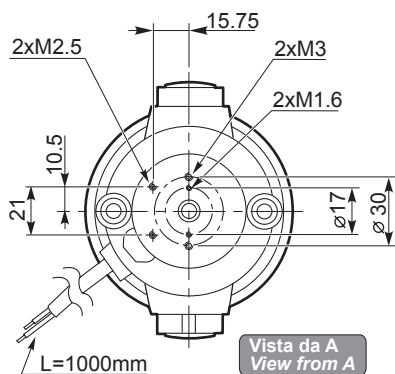

Freno / Brake → H23

Encoder → H24

Motori / Motors IP66 → I4

ECFT

O20

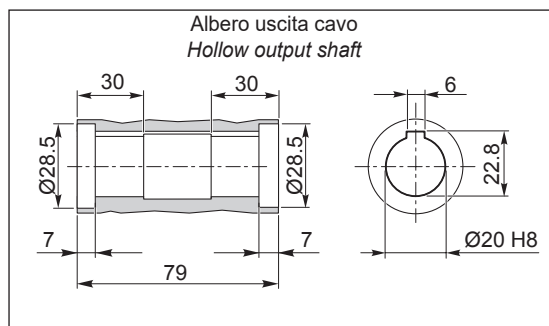

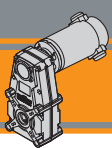

ECFT 180/146

ECFT 180/146 U

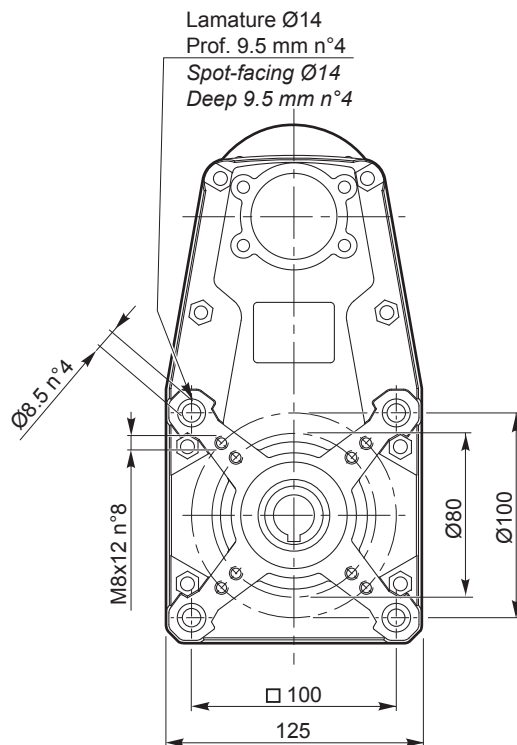
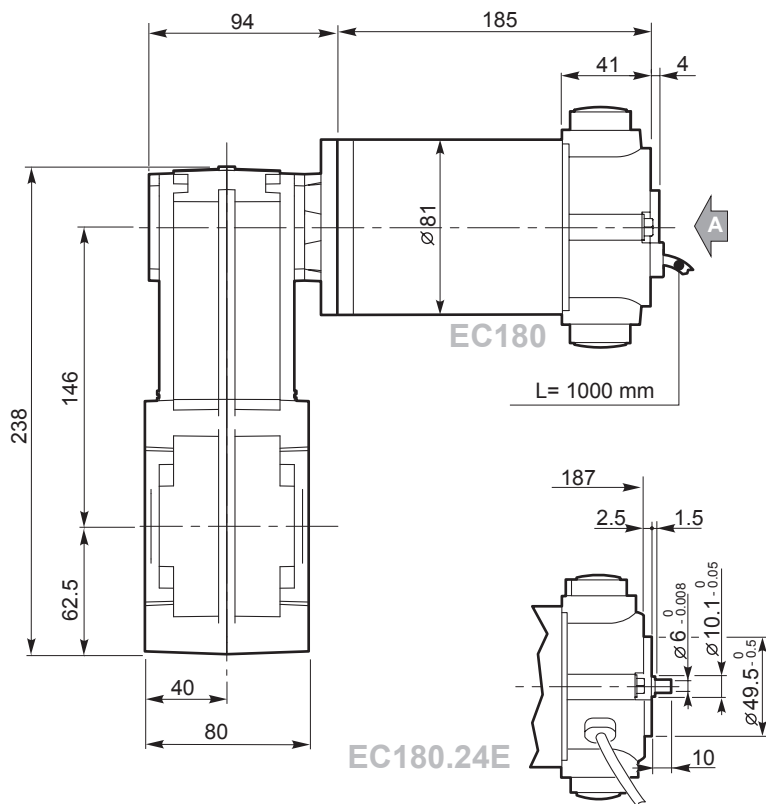

NOTA: Stessi fissaggi da entrambi i lati
NOTE: Same fixing points in both sides

Kg
8.1

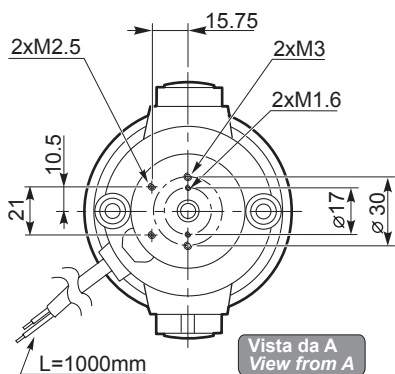

Freno / Brake → H23

Encoder → H24

Motori / Motors IP66 → I6

O20

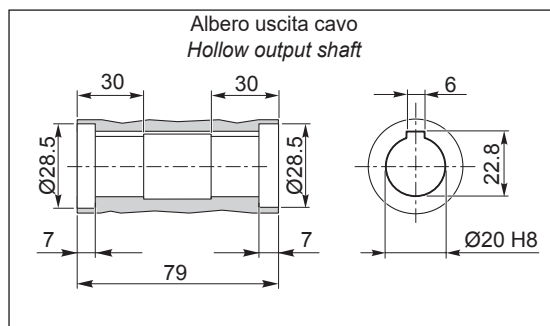

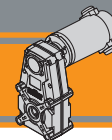

Dimensioni

Dimensions

ECFT 250/146

ECFT 250/146 U

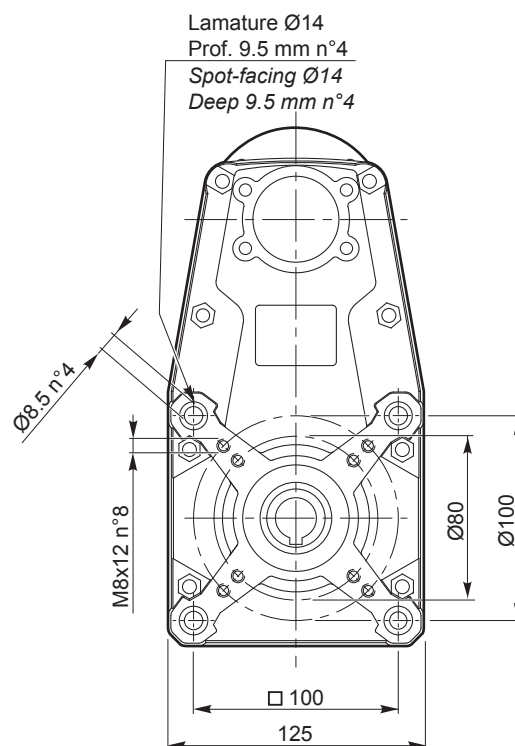
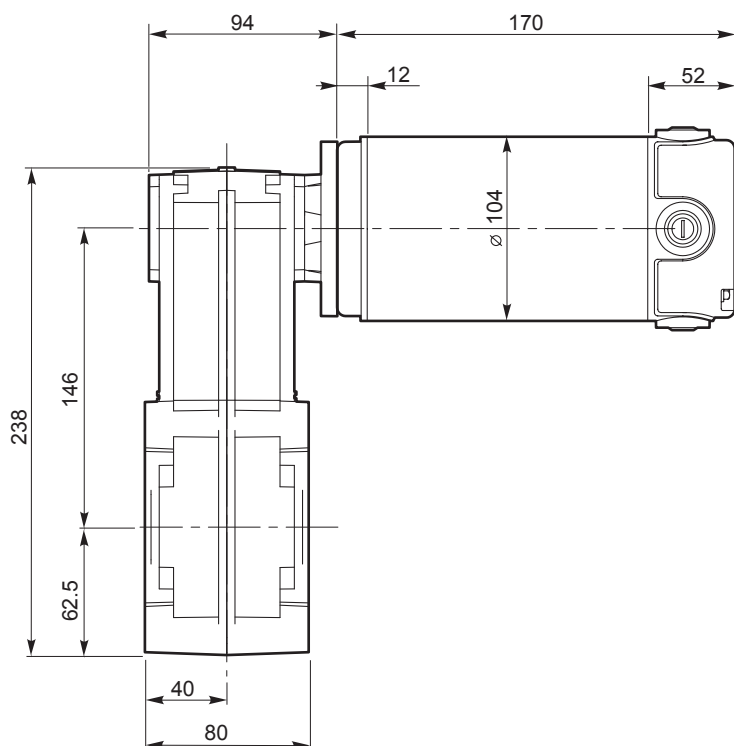

Kg
8.9

NOTA: Stessi fissaggi da entrambi i lati
NOTE: Same fixing points in both sides

Motori / Motors IP66

18

ECFT

O20

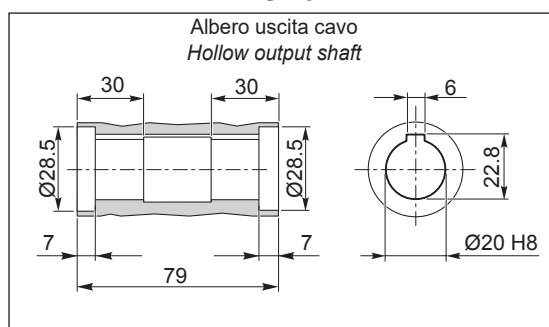

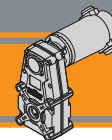

Dimensioni

Dimensions

ECFT 600/146

ECFT 600/146 U

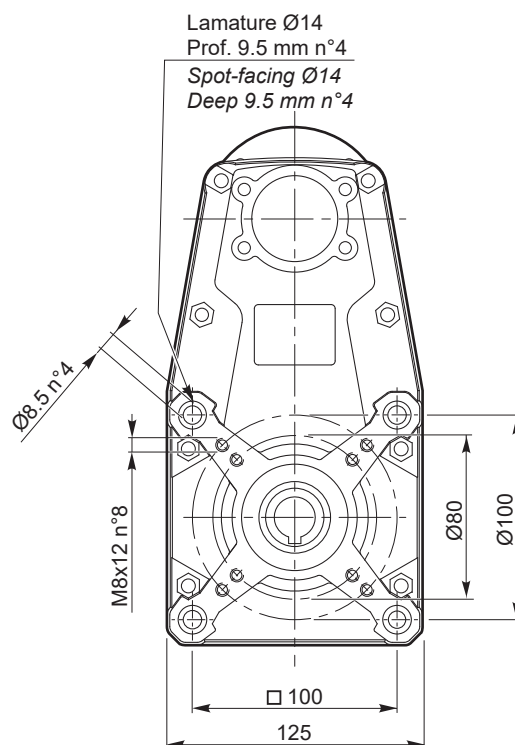
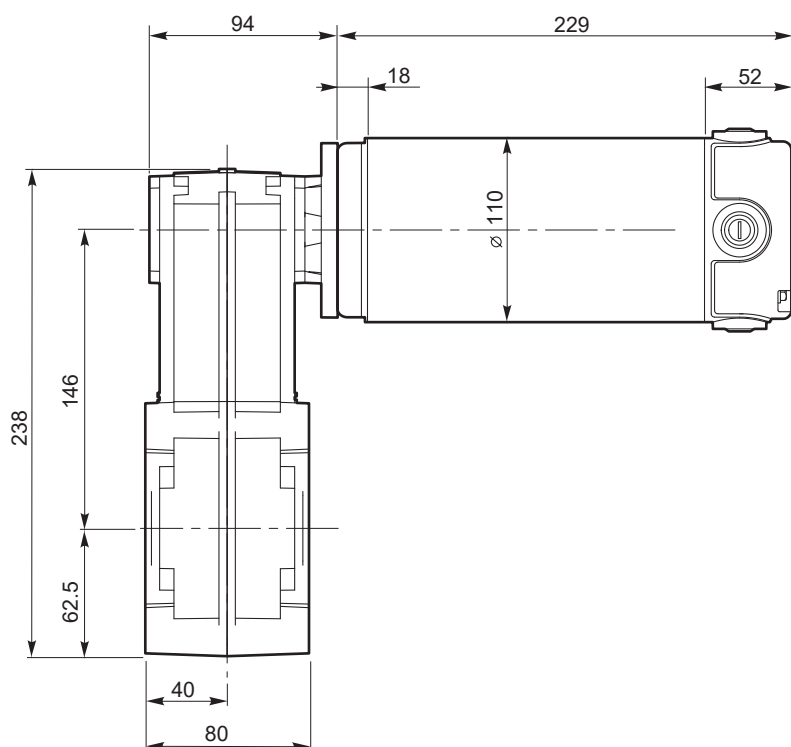

11.8

NOTA: Stessi fissaggi da entrambi i lati
NOTE: Same fixing points in both sides

Freno / Brake



Motori / Motors IP66



ECFT

O20

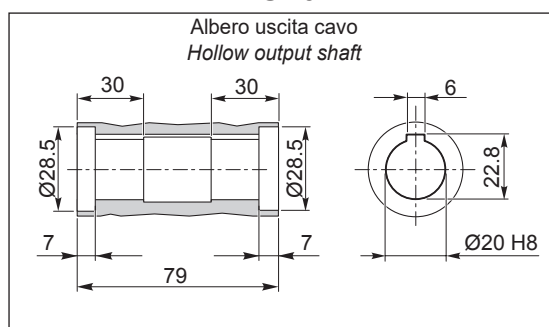

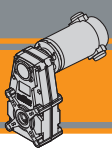

ECFT 250/196

ECFT 250/196 U

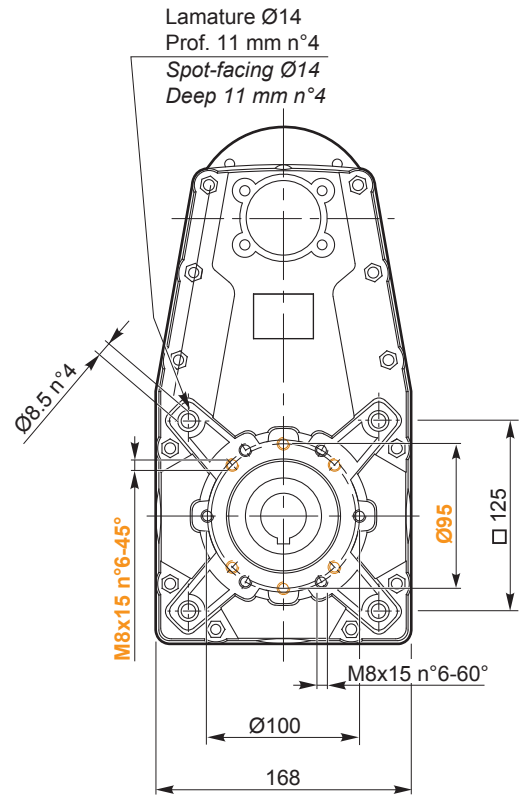
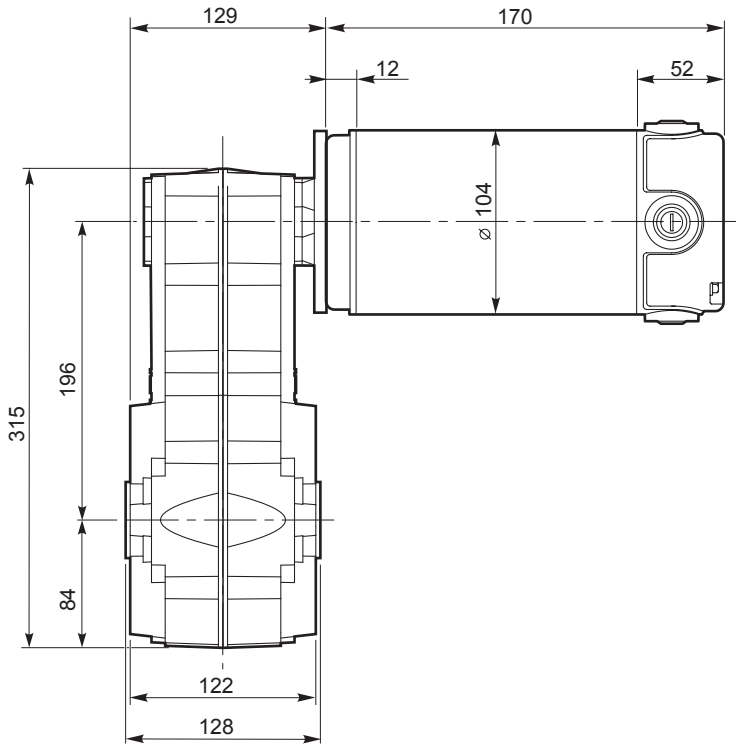

Kg
16.3

NOTA: Stessi fissaggi da entrambi i lati
NOTE: Same fixing points in both sides

Motori / Motors IP66

18

O30

Albero uscita cavo
Hollow output shaft

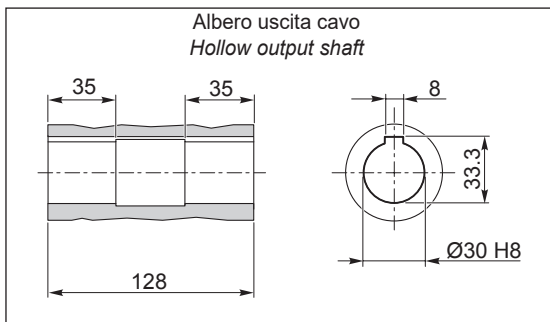

O35

Albero uscita cavo
Hollow output shaft

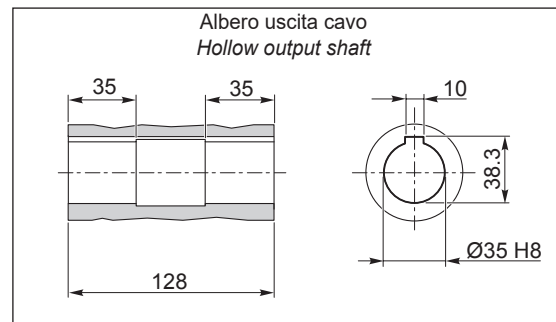

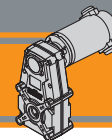

Dimensioni

Dimensions

ECFT 350/196

ECFT 350/196 U

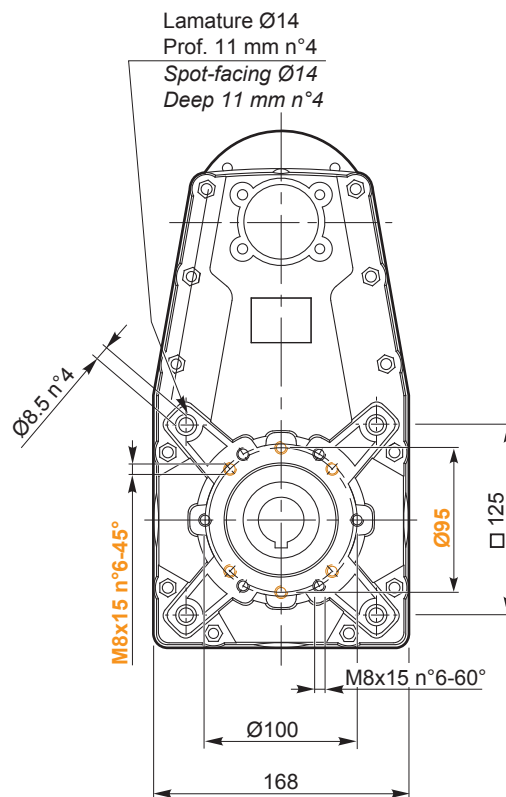
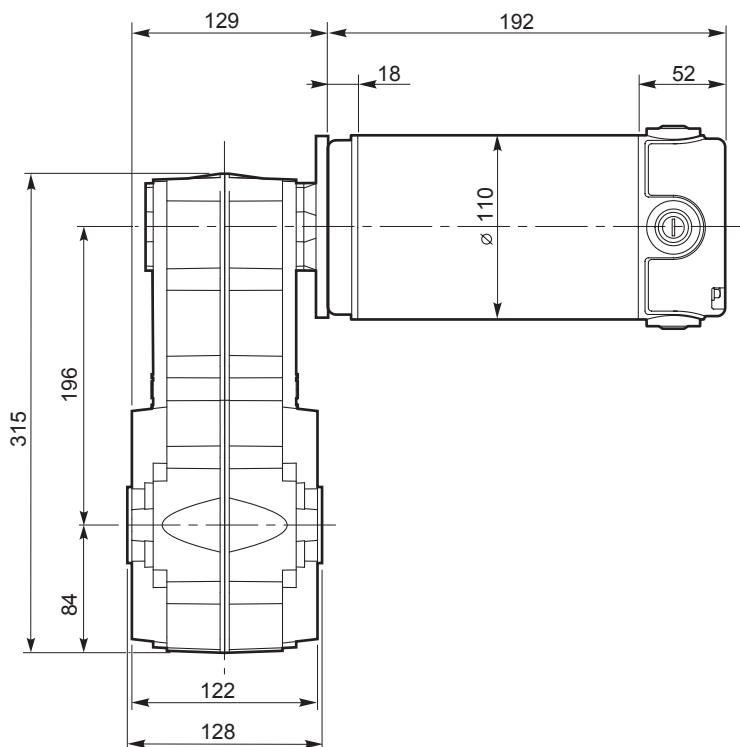

Kg
17.4

NOTA: Stessi fissaggi da entrambi i lati
NOTE: Same fixing points in both sides

Freno / Brake

H23

Motori / Motors IP66

I10

O30

Albero uscita cavo
Hollow output shaft

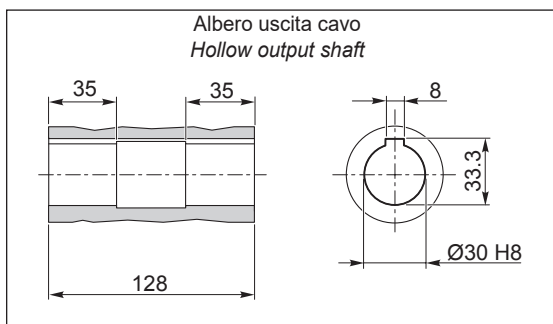

O35

Albero uscita cavo
Hollow output shaft

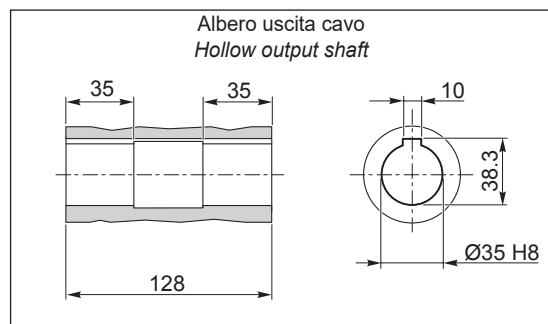

ECFT

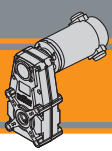

ECFT 600/196

ECFT 600/196 U

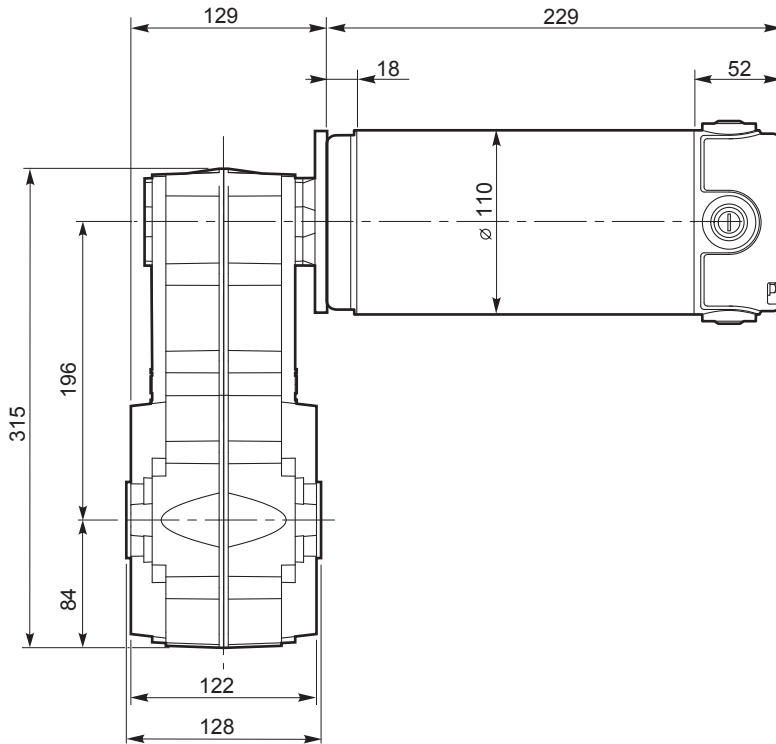

Kg
19.2

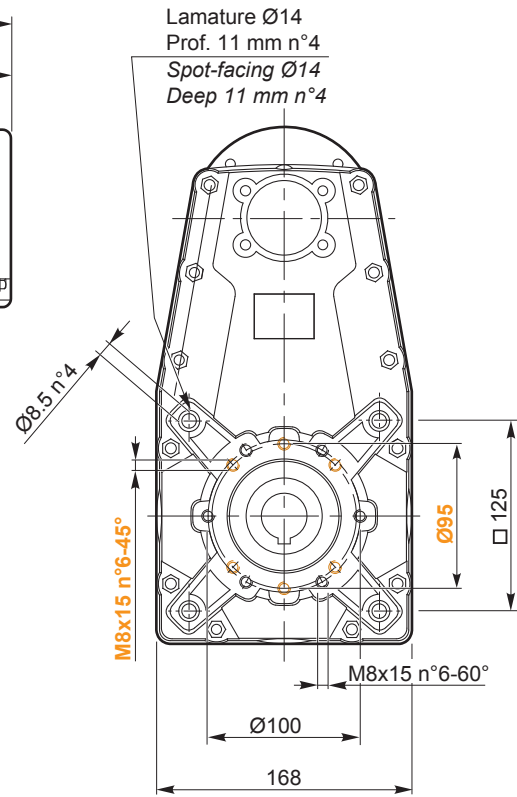

NOTA: Stessi fissaggi da entrambi i lati
NOTE: Same fixing points in both sides

Freno / Brake

H23

Motori / Motors IP66

I12

O30

Albero uscita cavo
Hollow output shaft

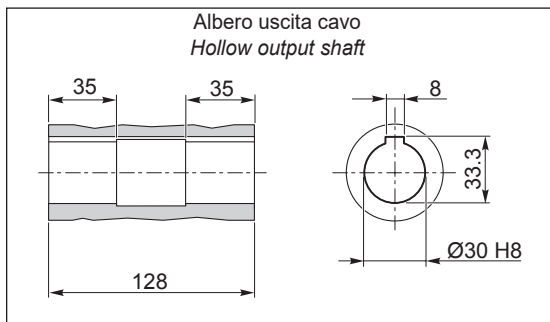

O35

Albero uscita cavo
Hollow output shaft

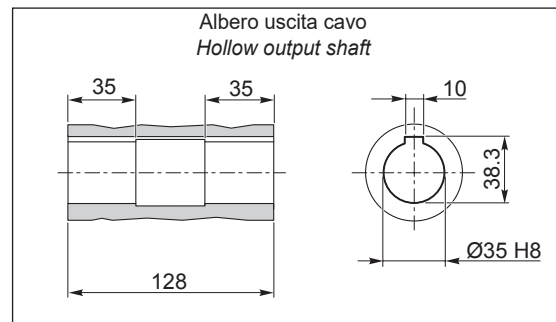



Ferrite

Motoriduttori CC a vite senza fine DC wormgearmotors

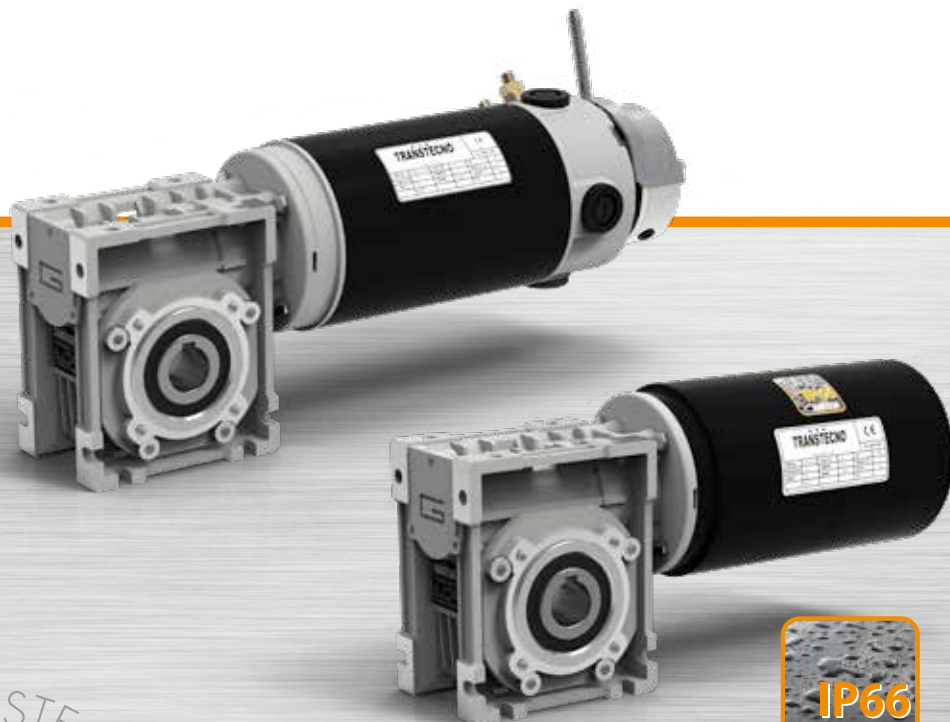

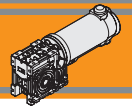

Indice	Index	Pag. Page
Caratteristiche tecniche	<i>Technical features</i>	02
Designazione	<i>Classification</i>	02
Simbologia	<i>Symbols</i>	02
Lubrificazione	<i>Lubrication</i>	03
Carichi radiali	<i>Radial loads</i>	03
Dati di dentatura	<i>Toothing data</i>	04
Rendimento	<i>Efficiency</i>	04
Dati tecnici per servizio S2	<i>Technical data for S2 duty</i>	05
Motori applicabili	<i>Motor adapters</i>	06
Dimensioni	<i>Dimensions</i>	07
Opzioni	<i>Options</i>	020
Accessori	<i>Accessories</i>	020

Questa sezione annulla e sostituisce ogni precedente edizione o revisione. Qualora questa sezione non Vi sia giunta in distribuzione controllata, l'aggiornamento dei dati ivi contenuto non è assicurato. **In tal caso la versione più aggiornata è disponibile sul nostro sito internet www.transtecno.com**

This section replaces any previous edition and revision. If you obtained this catalogue other than through controlled distribution channels, the most up to date content is not guaranteed. In this case the latest version is available on our web site www.transtecno.com

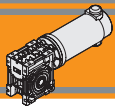

Caratteristiche tecniche

Technical features

Le caratteristiche principali dei motoriduttori CC a vite senza fine a magneti permanenti in ferrite serie ECM sono:

The main features of ECM ferrite permanent magnets DC wormgearmotors range are:

- Alimentazione in bassa tensione 12/24 Vcc
- Possibilità di montaggio encoder
- Potenze motore disponibili da 100 a 800W S2
- Magneti in ferrite
- Carcasse dei riduttori in pressofusione di alluminio
- Lubrificazione permanente con olio sintetico.
- Low voltage power supply 12/24 Vdc
- Suitable for encoder assembly
- Motor power ratings available from 100 to 800W S2
- Ferrite magnets
- Die-cast aluminum housing
- Permanent synthetic oil long-life lubrication.

Designazione

Classification

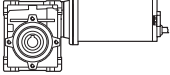
MOTORIDUTTORE / GEARMOTOR													
ECM	070/026						U	10	SZDX	BRSX	90	240	VS
Tipo Type	Grandezza Size						Versione Riduttore Gearbox Version	Rapporto Ratio	Albero di uscita Output shaft	Braccio di reazione Torque arm	Angolo Angle	Versione Motore Motor Version	Opzioni Options
	070/026	100/026	180/026	250/030	350/030	600/040	U F...	Vedere tabella See tables	SZDX SZSX DZ	BRDX BRSX	0° 90° 180° 270°	120 240 24E	VS
	070/026 (D11) 070/026 (D14) 070/030	100/0026 (D11) 100/026 (D14) 100/030 100/040	180/026 (D11) 180/026 (D14) 180/030 180/040 180/050	250/040 250/050 250/063	350/040 350/050 350/063 350/070	600/050 600/063 600/070							

Versione Riduttore
Gearbox Version

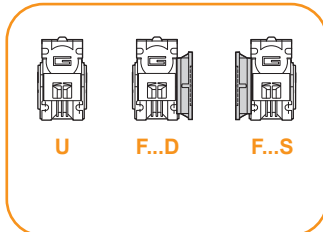

Albero di uscita
Output shaft

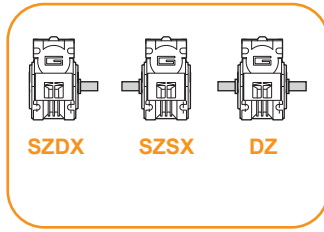

Braccio di reazione
Torque arm

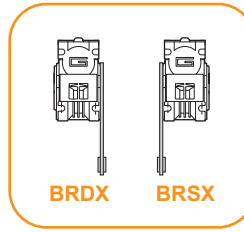

Angolo
Angle

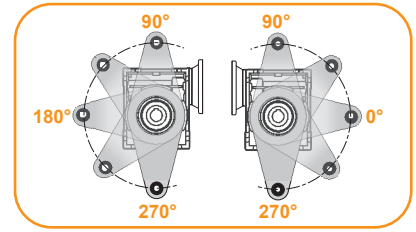

* NOTA: il braccio di reazione viene fornito smontato.
NOTE: the torque arm will be supplied not assembled.

Simbologia

Symbols

n_1	[min ⁻¹]	Velocità in ingresso / Input speed	R_d	%	Rendimento dinamico / Dynamic efficiency
n_2	[min ⁻¹]	Velocità in uscita / Output speed	A_2	[N]	Carico assiale ammissibile in uscita / Permitted output axial load
i		Rapporto di riduzione / Ratio	R_s	%	Rendimento statico / Static efficiency
P_1	[kW]	Potenza in entrata / Input power	R_2	[N]	Carico radiale ammissibile in uscita / Permitted output radial load
M_2	[Nm]	Coppia in uscita in funzione di P_1 / Output torque referred to P_1	Z		Numero di principi della vite / Worm starts
sf		Fattore di servizio / Service factor	β		Angolo d'elica / Helix angle



Lubrificazione

Lubrication

I riduttori a vite senza fine della serie CM sono lubrificati a vita con olio sintetico di viscosità 320 e possono essere installati in qualunque posizione di montaggio.

Permanent synthetic oil long-life lubrication allow to use CM wormgearbox range in all mounting position.

Carichi radiali

Radial loads

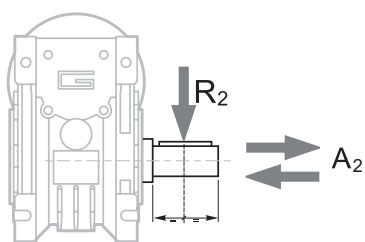

$A_2 = R_2 \times 0.2$

n ₂ [min ⁻¹]	R ₂ [N]					
	CM026	CM030	CM040	CM050	CM063	CM070
187	400	674	1264	1770	2445	2613
140	490	743	1392	1949	2692	2878
93	580	851	1596	2234	3085	3298
70	610	936	1754	2456	3392	3626
56	610	1008	1890	2646	3654	3906
47	610	1069	2004	2805	3874	4141
35	610	1179	2210	3095	4273	4568
28	610	1270	2381	3334	4603	4921
23	610	1356	2542	3559	4915	5254
18	610	1471	2759	3862	5334	5702
14	610	1600	3000	4200	5800	6200

Quando il carico radiale risultante non è applicato sulla mezzeria dell'albero occorre calcolare quello effettivo con la seguente formula:

When the resulting radial load is not applied on the centre line of the shaft it is necessary to calculate the effective load with the following formula:

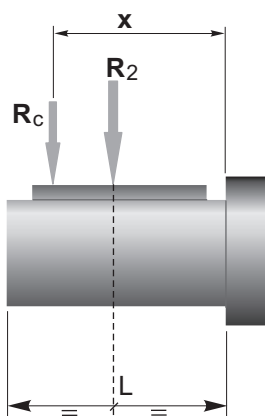

$$R_c = \frac{R_2 \cdot a}{(b + x)} \leq R_{2MAX}$$

$$R \leq R_c$$

a, b = valori riportati nella tabella
a, b = values given in the table

	CM					
	026	030	040	050	063	070
a	56	65	84	101	120	122
b	43	50	64	76	95	92
R _{2MAX}	610	1600	3000	4200	5800	6200

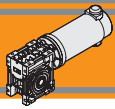

Dati di dentatura

Toothing data

	Dati della coppia vite-corona Worm wheel data	Rapporto / Ratio											
		5	7.5	10	15	20	25	30	40	50	60	80	100
CM026	Z	6	4	3	2	2		1	1	1	1		
	β	34° 35'	24° 41'	19° 1'	12° 57'	10° 30'		6° 33'	5° 17'	4° 26'	3° 49'		
CM030	Z	6	4	3	2	2	2	1	1	1	1	1	1
	β	27° 4'	24° 28'	18° 50'	12° 49'	10° 23'	8° 43'	6° 29'	5° 14'	4° 23'	3° 46'	2° 57'	2° 25'
CM040	Z	6	4	3	2	2	2	1	1	1	1	1	1
	β	34° 19'	24° 28'	18° 50'	12° 49'	10° 23'	8° 43'	6° 29'	5° 14'	4° 23'	3° 46'	2° 57'	2° 25'
CM050	Z	6	4	3	2	2	2	1	1	1	1	1	1
	β	33° 37'	23° 54'	18° 23'	12° 29'	10° 6'	8° 28'	6° 19'	5° 5'	4° 15'	3° 39'	2° 51'	2° 20'
CM063	Z	6	4	3	2	2	2	1	1	1	1	1	1
	β	34° 23'	24° 31'	18° 53'	12° 50'	10° 24'	8° 44'	6° 30'	5° 14'	4° 23'	3° 47'	2° 57'	2° 25'
CM070	Z		4	3	2	2	2	1	1	1	1	1	1
	β		26° 12'	20° 15'	13° 49'	11° 15'	9° 29'	7° 0'	5° 41'	4° 46'	4° 7'	3° 13'	2° 39'

Rendimento

Efficiency

	n_1 [min ⁻¹]	Rendimento Efficiency	Rapporto / Ratio											
			5	7.5	10	15	20	25	30	40	50	60	80	100
CM026	2800	Rd	89	87	85	83	80		73	68	64	60		
	1400		87	84	83	78	74		66	61	57	53		
	900		84	83	80	75	71		61	57	52	48		
			Rs	72	71	68	61	56		46	41	36	34	
CM030	2800	Rd	89	88	86	84	81	78	74	70	65	62	57	52
	1400		86	85	84	79	75	72	67	62	58	55	48	43
	900		84	83	81	75	71	68	62	58	53	49	43	39
			Rs	72	67	63	55	50	43	39	35	31	27	23
CM040	2800	Rd	90	89	87	84	83	80	77	73	69	66	60	56
	1400		88	86	84	81	78	74	70	65	60	58	52	46
	900		86	84	82	77	74	70	66	60	57	53	46	41
			Rs	74	71	67	60	55	51	45	40	36	32	28
CM050	2800	Rd	91	90	88	86	84	82	78	74	71	68	62	58
	1400		89	87	85	82	79	76	72	67	63	60	54	49
	900		87	85	84	79	75	72	68	62	59	55	48	43
			Rs	73	70	66	59	55	51	44	39	35	32	27
CM063	2800	Rd	91	90	88	86	84	83	79	76	73	70	65	60
	1400		90	88	86	84	81	78	75	70	66	63	57	52
	900		89	86	84	81	78	75	70	65	61	58	52	47
			Rs	73	71	67	60	55	51	45	40	36	33	28
CM070	2800	Rd		90	89	87	85	84	80	77	74	72	67	62
	1400			89	87	84	82	80	76	72	68	65	60	53
	900			87	85	82	79	77	72	67	63	60	54	49
			Rs		72	69	62	60	55	48	43	38	36	31



Rendimento teorico del riduttore dopo il rodaggio
Theoretical efficiency of the gearbox after the first running period





Dati tecnici per servizio S2

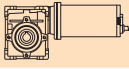
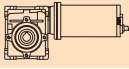
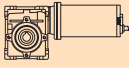
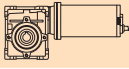

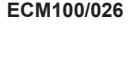
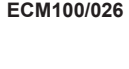
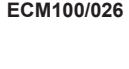

Technical data for S2 duty

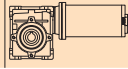
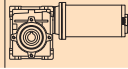

P ₁ [W]	n ₂ [min ⁻¹]	M ₂ [Nm]	sf	i		Versione motore Motor version		
100								
(3000 min ⁻¹)	600	1.4	7.1	5		ECM070/026 12E/24E		
	400	2.1	5.3	7.5				
	300	2.7	4.1	10				
	200	4.0	2.8	15				
	150	5.1	2.2	20				
	100	7.0	1.7	30				
	75	8.7	1.3	40				
	60	10	1.0	50				
	50	11	0.8	60				
	150	5.2	2.7	20				ECM070/030 12E/24E
	120	6.2	2.4	25				
	100	7.1	2.5	30				
	75	8.9	1.8	40				
	60	10	1.4	50				
	50	12	1.2	60				
	38	15	0.8	80				
	30	17	0.7	100				
	50	13	2.3	60		ECM070/040 12E/24E		
	38	15	1.8	80				
	30	18	1.4	100				

P ₁ [W]	n ₂ [min ⁻¹]	M ₂ [Nm]	sf	i		Versione motore Motor version
140						
(3000 min ⁻¹)	600	2.0	5.0	5		ECM100/026 120/240/24E
	400	2.9	3.8	7.5		
	300	3.8	2.9	10		
	200	5.5	2.0	15		
	150	7.1	1.5	20		
	100	10	1.2	30		
	75	12	0.9	40		
	60	14	0.7	50		
	50	13	0.7	60		
	200	5.6	2.8	15		
	150	7.2	1.9	20		
	120	8.7	1.7	25		
	100	10	1.8	30		
	75	12	1.3	40		
	60	14	1.0	50		
	50	17	0.8	60		
	38	17	0.7	80		
	30	16	0.7	100		
	100	10	3.7	30		ECM100/040 120/240/24E
	75	13	2.6	40		
	60	15	2.1	50		
	50	18	1.6	60		
	38	21	1.3	80		
	30	25	1.0	100		

P ₁ [W]	n ₂ [min ⁻¹]	M ₂ [Nm]	sf	i		Versione motore Motor version
250						
(3000 min ⁻¹)	600	3.5	2.8	5		ECM180/026 120/240
	400	5.2	2.1	7.5		
	300	6.8	1.6	10		
	200	10	1.1	15		
	150	13	0.9	20		
	100	17	0.7	30		
	75	16	0.7	40		
	60	14	0.7	50		
	50	13	0.7	60		
	600	3.5	3.7	5		
	400	5.3	2.9	7.5		
	300	6.8	2.3	10		
	200	10	1.6	15		
	150	13	1.1	20		
	120	16	1.0	25		
	100	18	1.0	30		
	75	22	0.7	40		
	60	21	0.7	50		
	50	20	0.7	60		
	38	17	0.7	80		
	30	16	0.7	100		

P ₁ [W]	n ₂ [min ⁻¹]	M ₂ [Nm]	sf	i		Versione motore Motor version
250						
(3000 min ⁻¹)	200	10	3.5	15		ECM180/040 120/240/24E
	150	13	2.3	20		
	120	16	1.8	25		
	100	18	2.1	30		
	75	23	1.5	40		
	60	27	1.2	50		
	50	32	0.9	60		
	38	38	0.7	80		
	30	34	0.7	100		
	75	24	2.5	40		
	60	28	2.0	50		
	50	32	1.6	60		
	38	39	1.2	80		
	30	46	0.9	100		

P ₁ [W]	n ₂ [min ⁻¹]	M ₂ [Nm]	sf	i		Versione motore Motor version
350						
(3000 min ⁻¹)	600	5.0	2.6	5		ECM250/030 120/240
	400	7.4	2.0	7.5		
	300	10	1.7	10		
	200	14	1.1	15		
	150	18	0.8	20		
	120	22	0.7	25		
	100	25	0.7	30		
	75	22	0.7	40		
	60	21	0.7	50		
	200	14	2.5	15		
	150	18	1.7	20		
	120	22	1.3	25		
	100	26	1.5	30		
	75	33	1.0	40		
	60	38	0.8	50		
	50	44	0.7	60		
	38	38	0.7	80		
	30	35	0.7	100		
	150	19	2.9	20		ECM250/050 120/240
	120	23	2.2	25		
	100	26	2.6	30		
	75	33	1.8	40		
	60	40	1.4	50		
	50	45	1.1	60		
	38	55	0.8	80		
	30	65	0.7	100		
	75	34	3.3	40		ECM250/063 120/240
	60	41	2.5	50		
	50	47	2.1	60		
	38	58	1.5	80		
	30	67	1.2	100		

P ₁ [W]	n ₂ [min ⁻¹]	M ₂ [Nm]	sf	i		Versione motore Motor version
500						
(3000 min ⁻¹)	600	7.1	1.8	5		ECM350/030 120/240
	400	11	1.4	7.5		
	300	14	1.2	10		
	200	20	0.8	15		
	150	20	0.7	20		
	120	21	0.7	25		
	100	26	0.7	30		
	75	23	0.7	40		
	60	21	0.7	50		

N.B.
Verificare sempre che la coppia M₂ utilizzata non ecceda il valore indicato nelle caselle in grigio
N.B.
Please check that the output torque M₂ does not exceed the value in the grey areas

NOTA: per servizio continuo o altamente intermittente, contattare il servizio tecnico

NOTE: for continuous or highly intermittent duty, please contact our technical service

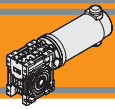

Dati tecnici per servizio S2

Technical data for S2 duty

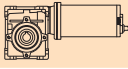
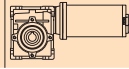
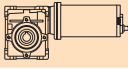
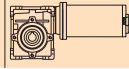
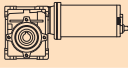
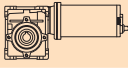
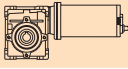
P ₁ [W]	n ₂ [min ⁻¹]	M ₂ [Nm]	sf	i		Versione motore Motor version	P ₁ [W]	n ₂ [min ⁻¹]	M ₂ [Nm]	sf	i		Versione motore Motor version			
500							800									
(3000 min ⁻¹)	600	7.2	4.0	5		ECM350/040	120/240	(3000 min ⁻¹)	600	11	2.5	5		ECM600/040	120/240	
	400	11	2.9	7.5				400	17	1.8	7.5					
	300	14	2.4	10				300	22	1.5	10					
	200	20	1.7	15				200	32	1.1	15					
	150	26	1.2	20				150	42	0.7	20					
	120	32	0.9	25				120	40	0.7	25					
	100	37	1.0	30				100	54	0.7	30					
	75	46	0.7	40				75	49	0.7	40					
	60	46	0.7	50				600/050	12	4.7	5	ECM600/050			120/240	
	50	41	0.7	60				400	17	3.3	7.5					
	38	39	0.7	80		300	22	2.7	10							
	30	34	0.7	100		200	33	1.9	15							
	200	21	3.0	15		ECM350/050	120/240	150	43	1.3	20					
	150	27	2.1	20				120	52	1.0	25					
	120	33	1.6	25				100	60	1.1	30					
	100	37	1.8	30				75	75	0.8	40					
	75	47	1.3	40				60	81	0.7	50					
	60	57	1.0	50				50	74	0.7	60					
	50	65	0.8	60				38	66	0.7	80					
	38	66	0.7	80				200	33	3.5	15	ECM600/063	120/240			
	30	61	0.7	100				150	43	2.4	20					
	75	48	2.3	40				ECM350/063	120/240	120	53			1.8	25	
	60	58	1.8	50		100			60	2.1	30					
	50	67	1.5	60		75			77	1.4	40					
	38	83	1.1	80		60			93	1.1	50					
	30	96	0.8	100		50			107	0.9	60					
	60	59	2.5	50		ECM350/070			120/240	38	132			0.7	80	
	50	69	2.1	60						30	114			0.7	100	
	38	85	1.5	80						120	53			2.6	25	ECM600/070
	30	99	1.2	100						100	61	3.0	30			
	75	48	2.3	40						75	78	2.1	40			
	60	58	1.8	50				60	94	1.6	50					
	50	67	1.5	60				50	110	1.3	60					
	38	83	1.1	80				38	137	0.9	80					
	30	96	0.8	100				30	158	0.7	100					

N.B.
Verificare sempre che la coppia M₂ utilizzata non ecceda il valore indicato nelle caselle in grigio
N.B.
Please check that the output torque M₂ does not exceed the value in the grey areas

NOTA: per servizio continuo o altamente intermittente, contattare il servizio tecnico
NOTE: for continuous or highly intermittent duty, please contact our technical service

Motori applicabili

Motor adapters

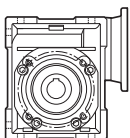
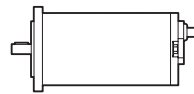

		EC						
		070.12E 070.24E	100.120 100.240 100.24E	180.120 180.240	180.24E	250.120 250.240	350.120 350.240	600.120 600.240
CM	026	5-60	5-60	5-60				
	030	5-100	5-100	5-100	5-50	5-50	5-50	
	040		5-100	5-100	5-100	5-100	5-100	5-40
	050			40-100	5-100	5-100	15-100	5-80
	063					40-100	40-100	15-100
	070						50-100	25-100

5-100

Rapporti di riduzione i
Ratio i

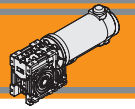

Dimensioni

Dimensions

ECM070/026 U

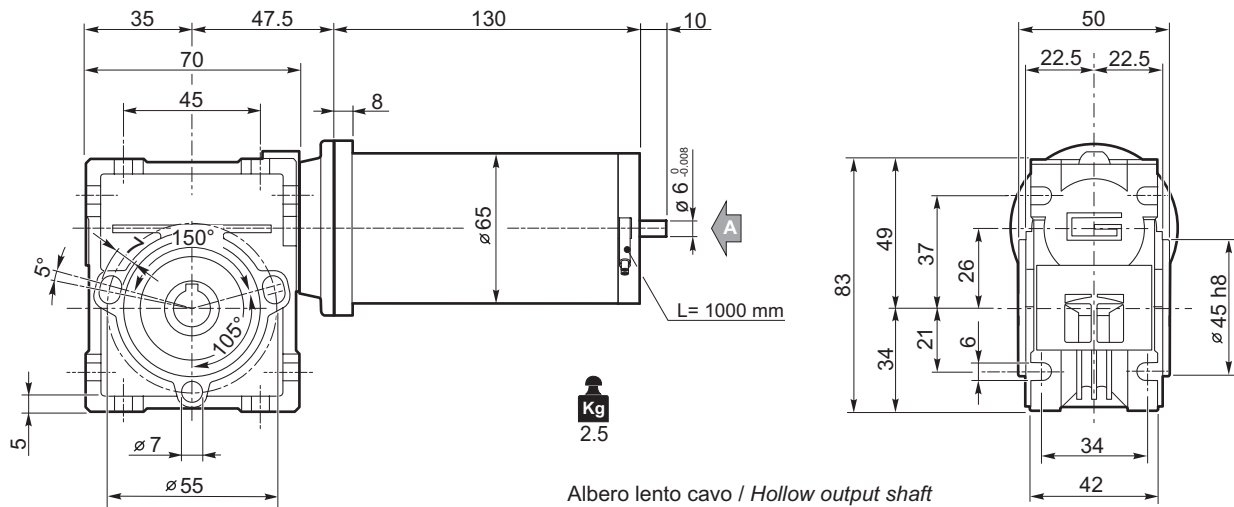

Kg
2.5

Albero lento cavo / Hollow output shaft

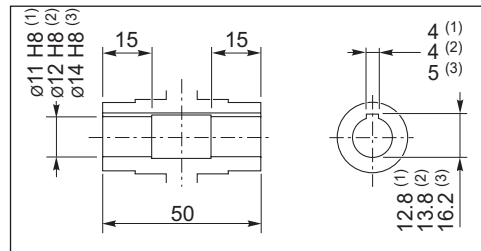

- (1): ECM 070/026 (D11)
- (2): ECM 070/026
- (3): ECM 070/026 (D14)

Vista da A
View from A

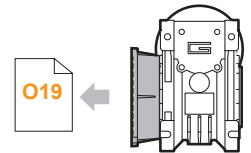
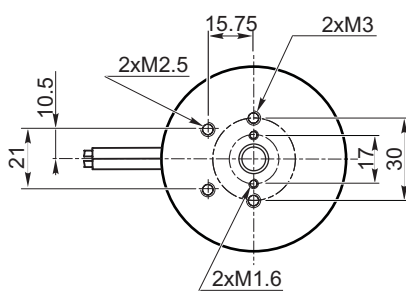

ECM070/026 F...

Motori / Motors IP66

I2

Freno / Brake

H23

Encoder

H24

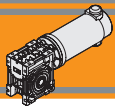

Dimensioni

Dimensions

ECM070/030 U

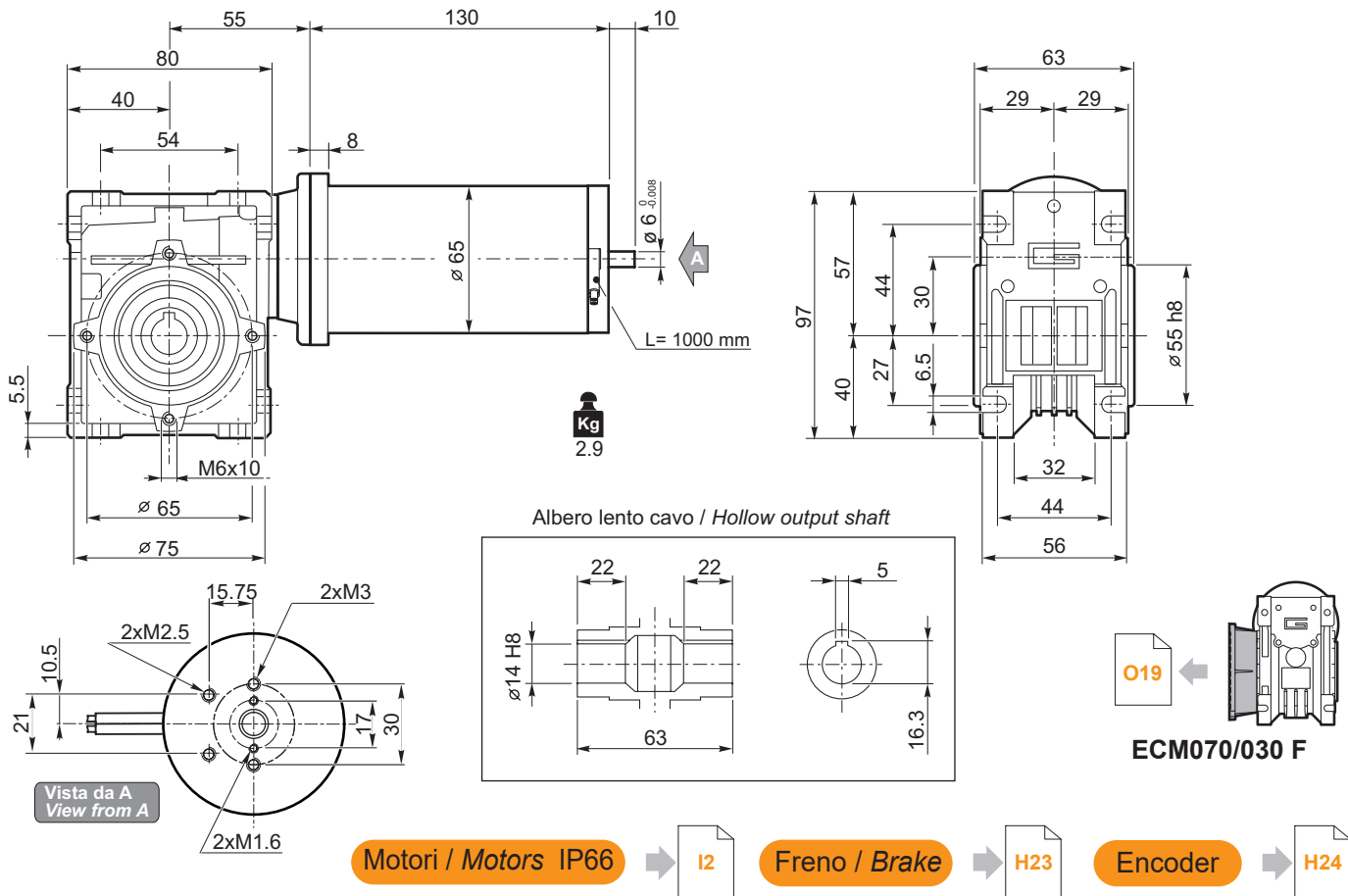

ECM100/026 U

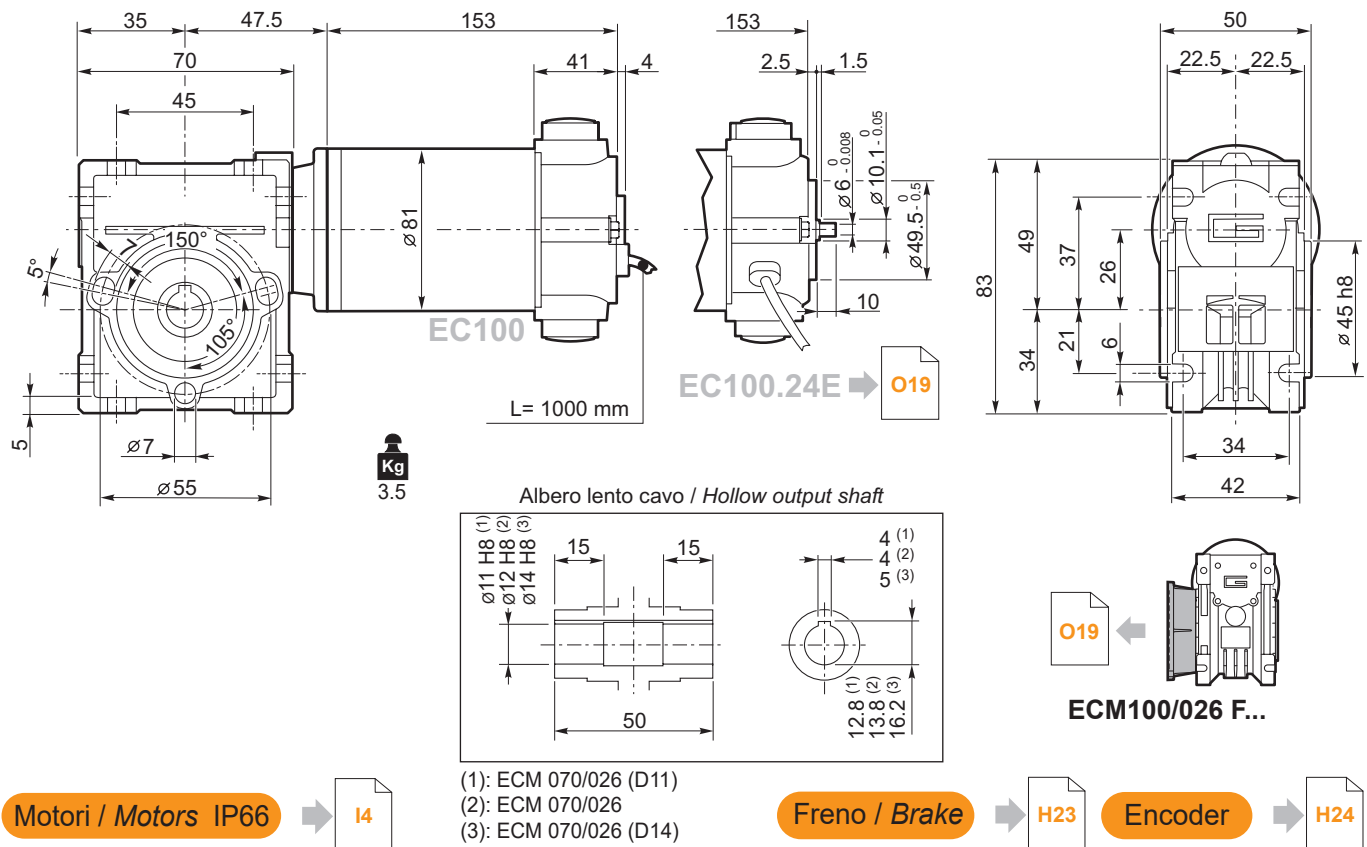



Dimensioni

Dimensions

ECM100/030 U

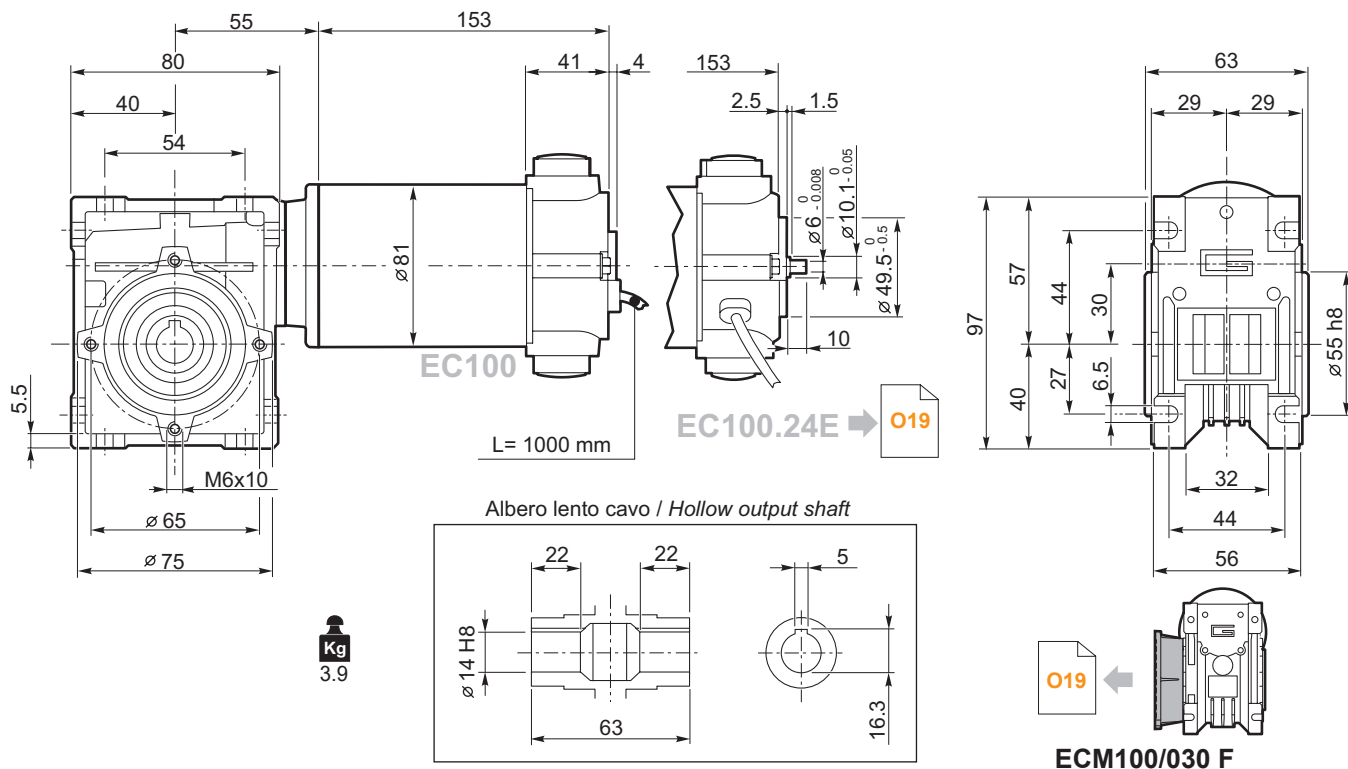

ECM100/040 U

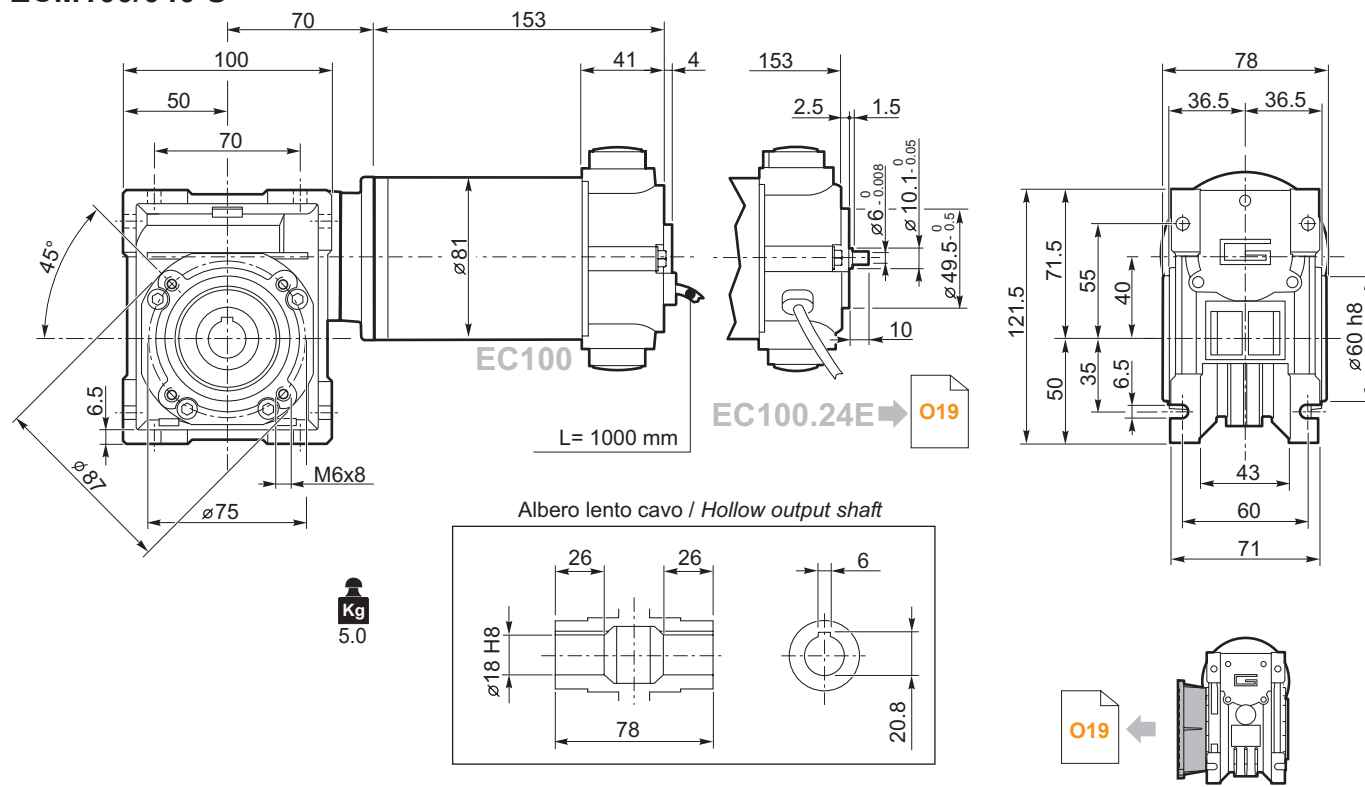

ECM

ECM100/040 F
ECM100/040 FL
ECM100/040 FB

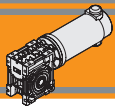

Dimensioni

Dimensions

ECM180/026 U

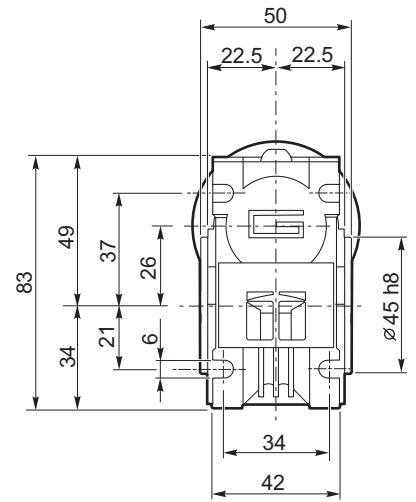
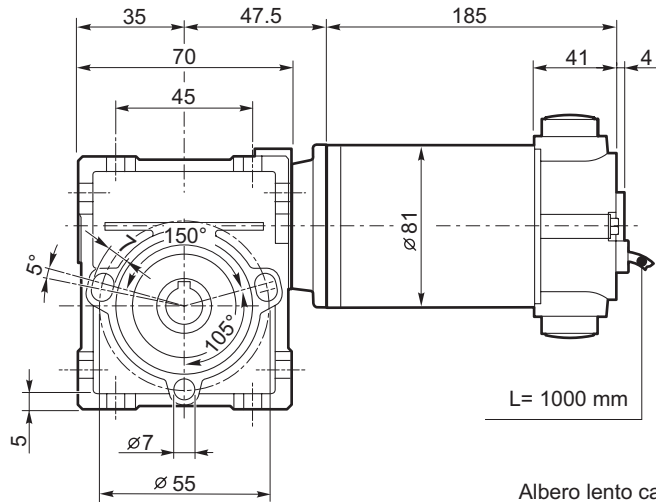

Kg
4.2

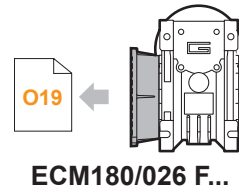
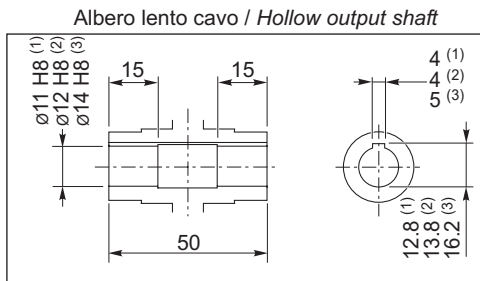

Motori / Motors IP66



- (1): ECM 070/026 (D11)
- (2): ECM 070/026
- (3): ECM 070/026 (D14)

Freno / Brake



Encoder



ECM180/030 U

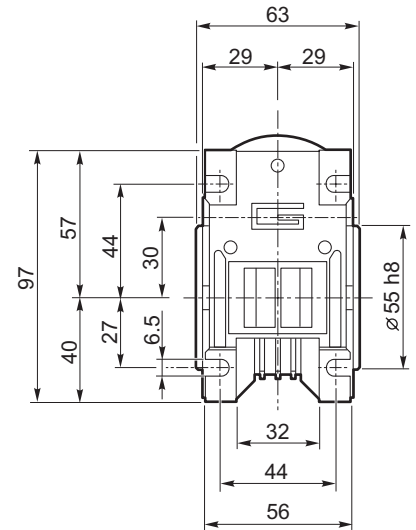
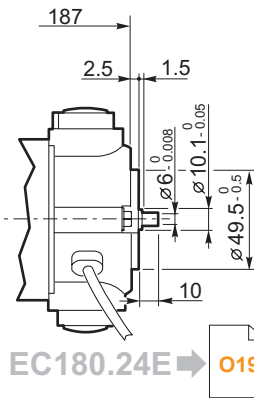
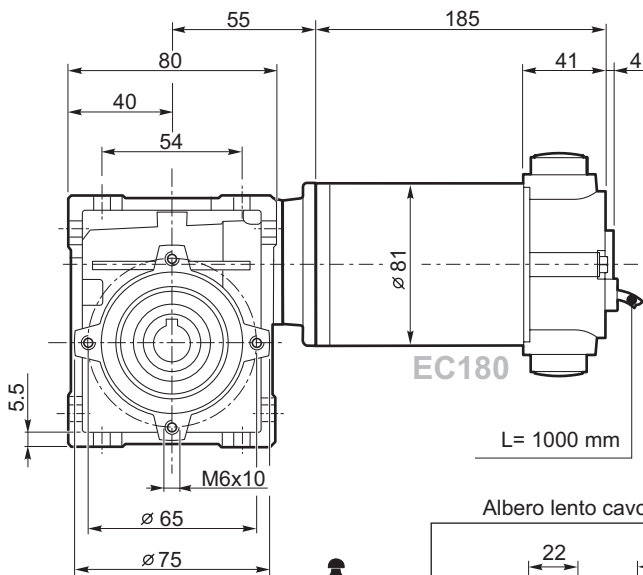

Kg
4.6

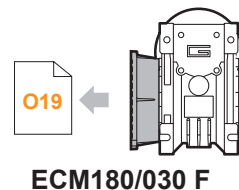
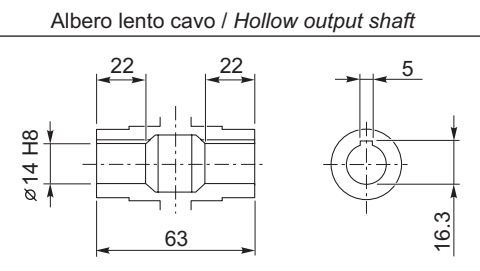

Motori / Motors IP66



Freno / Brake



Encoder





Dimensioni

Dimensions

ECM180/040 U

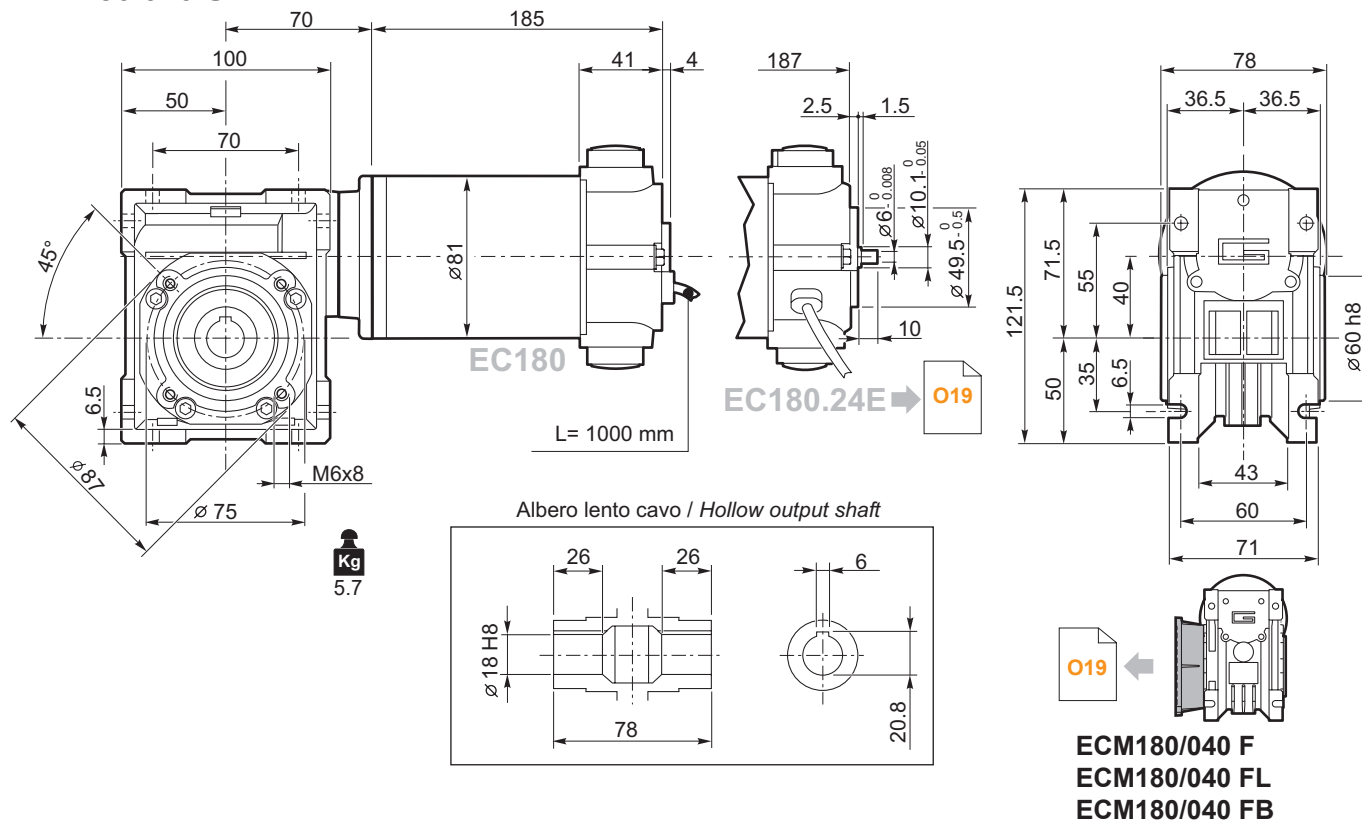

Motori / Motors IP66 → 16

Freno / Brake → H23

Encoder → H24

ECM180/050 U

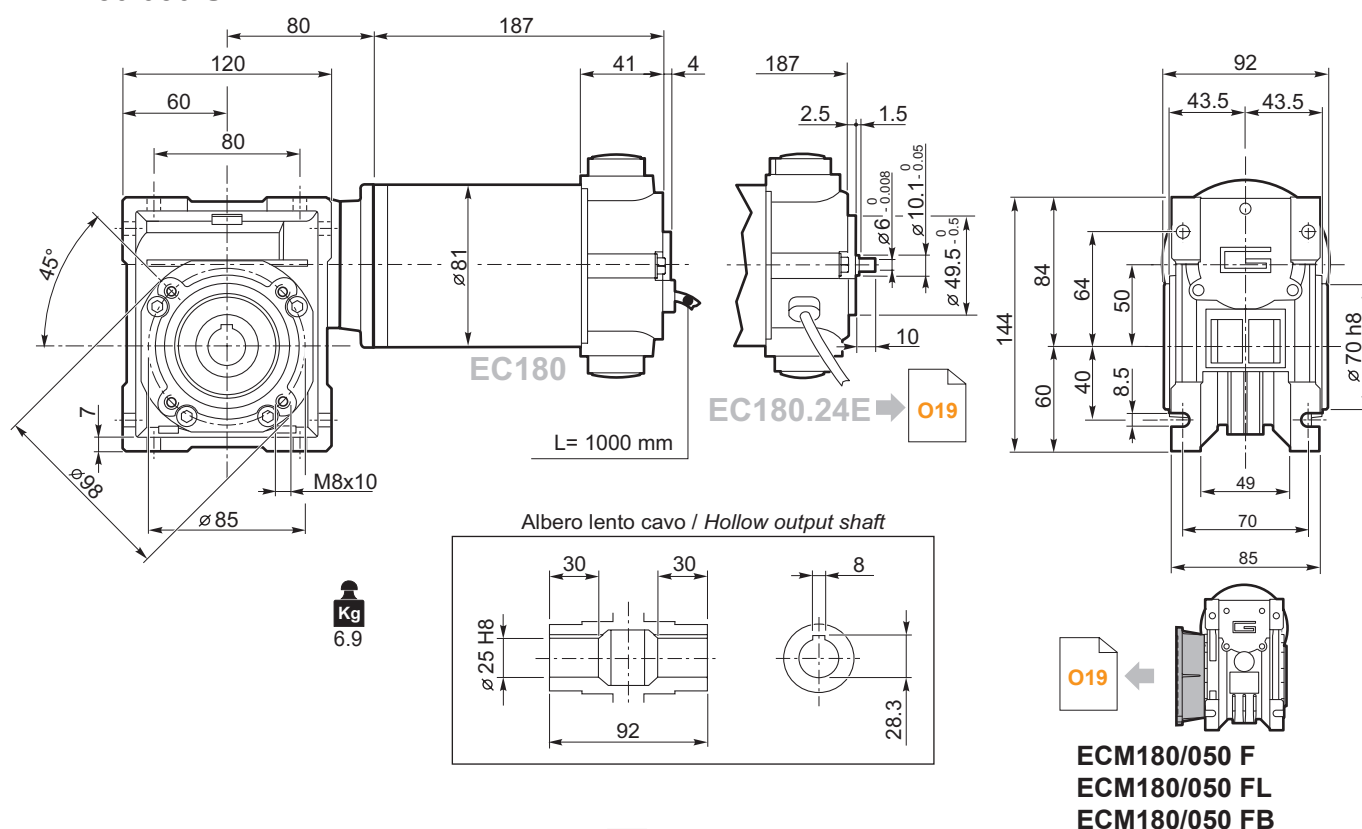

Motori / Motors IP66 → 16

Freno / Brake → H23

Encoder → H24

ECM

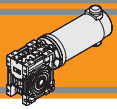

Dimensioni

Dimensions

ECM250/030 U

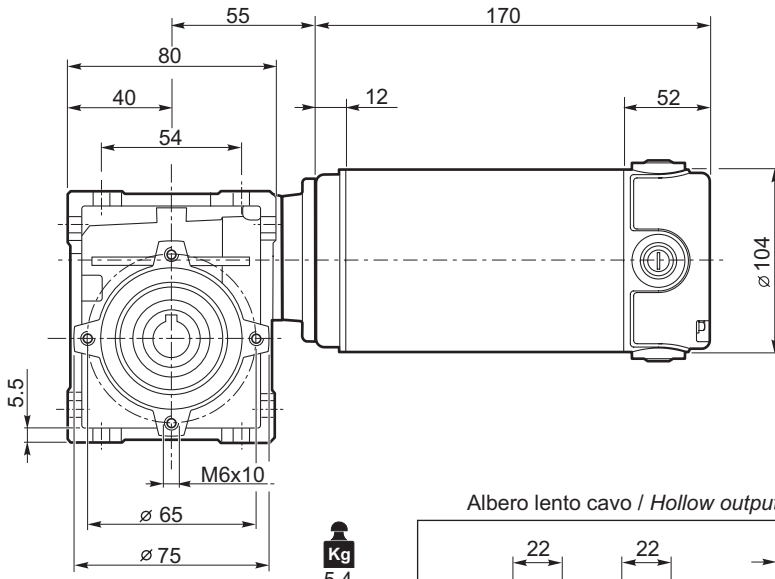

Kg
5.4

Albero lento cavo / Hollow output shaft

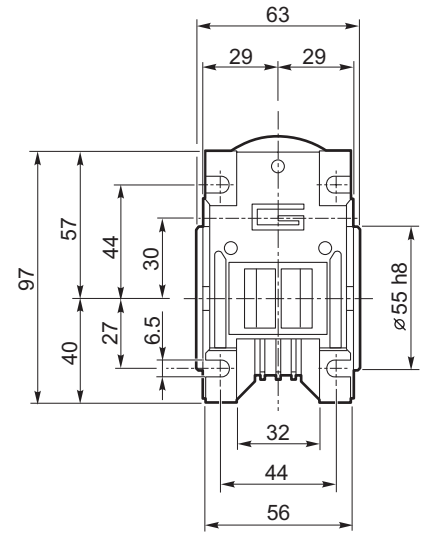
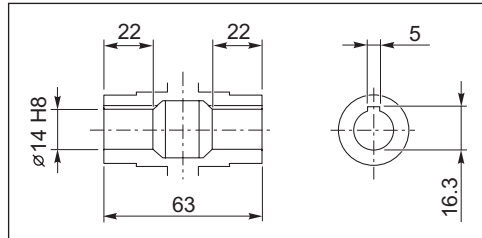

O19

ECM250/030 F

Motori / Motors IP66

18

ECM250/040 U

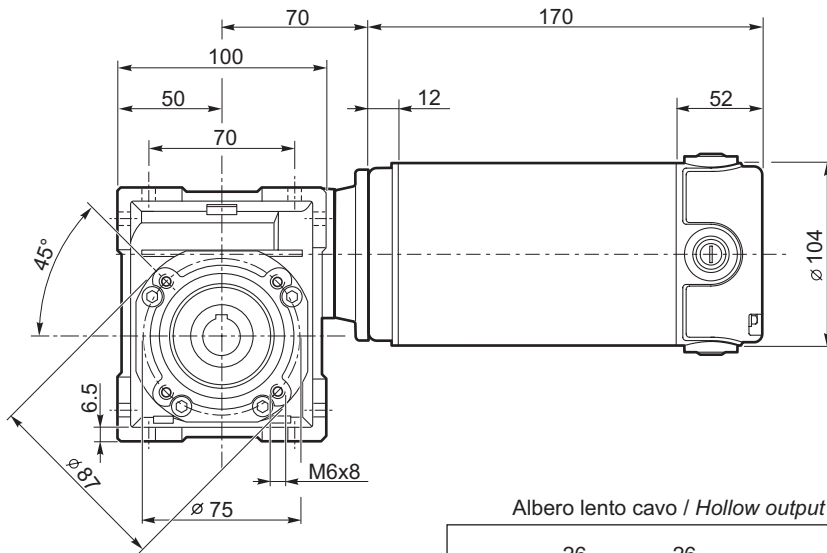

Kg
6.5

Albero lento cavo / Hollow output shaft

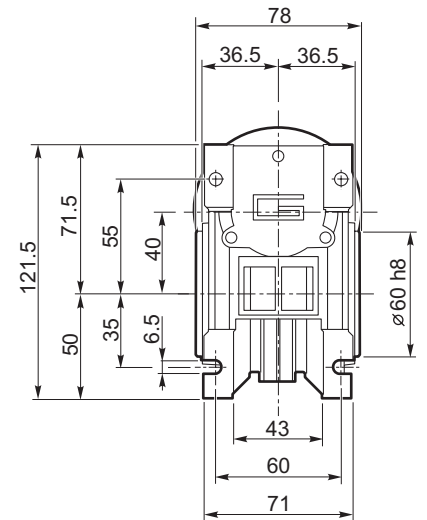
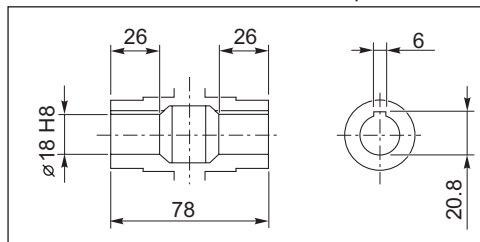

O19

**ECM250/040 F
ECM250/040 FL
ECM250/040 FB**

Motori / Motors IP66

18



Dimensioni

Dimensions

ECM250/050 U

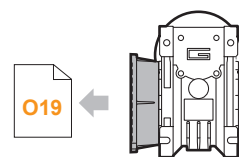
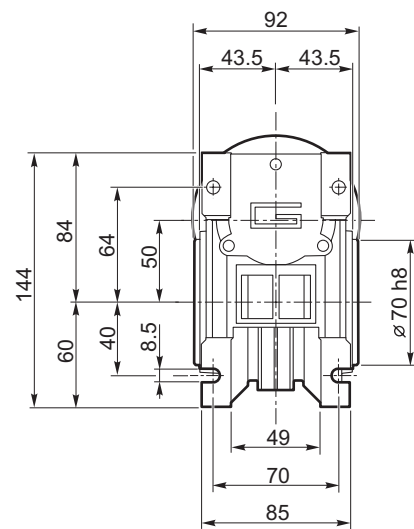
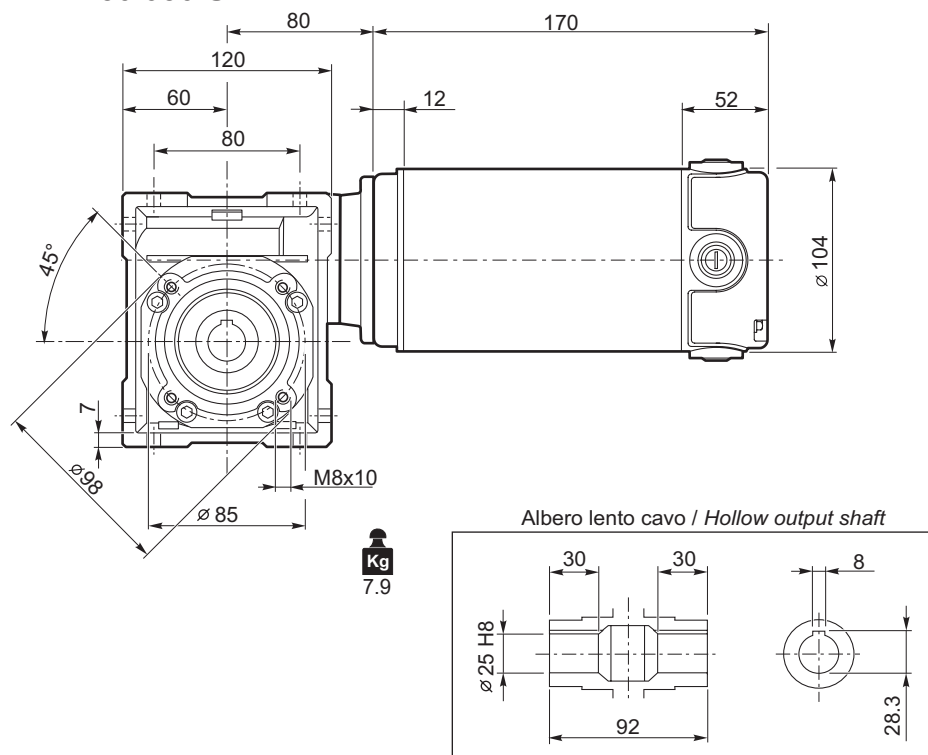

ECM250/050 F
ECM250/050 FL
ECM250/050 FB

Motori / Motors IP66 → 18

ECM250/063 U

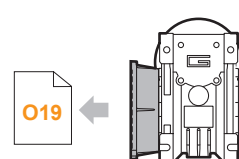
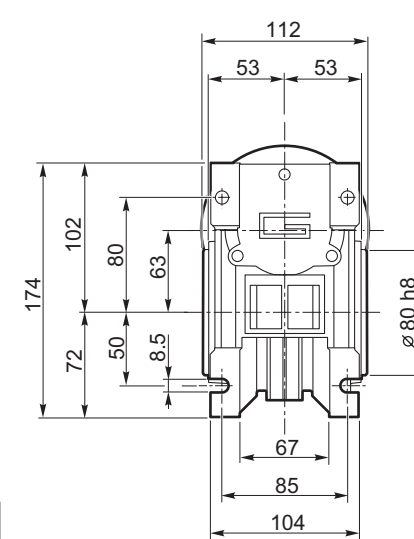
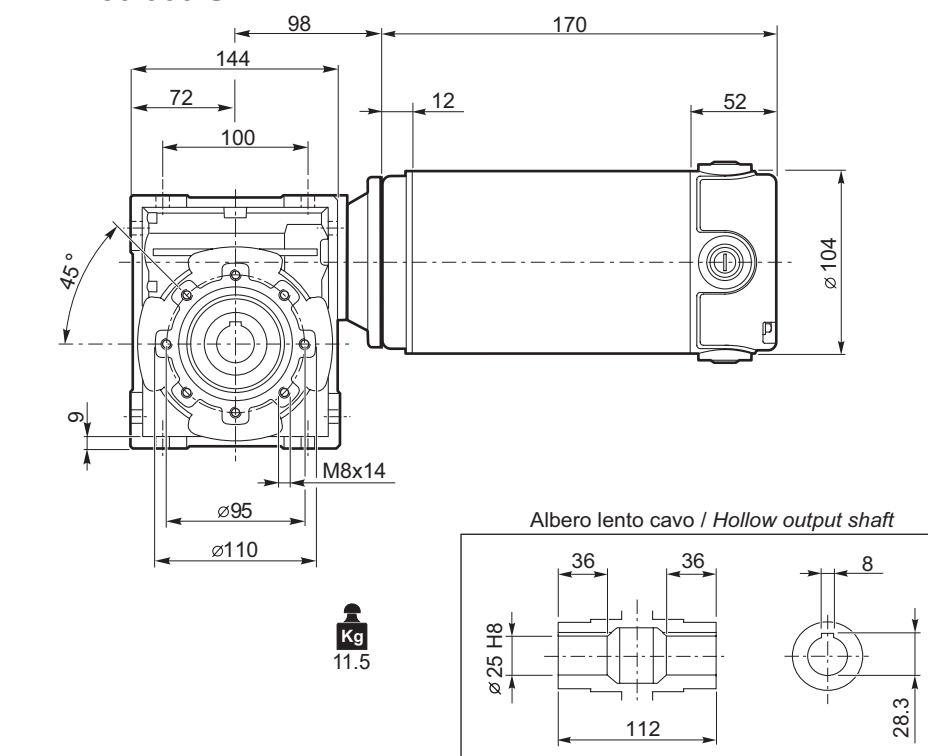

ECM250/063 F
ECM250/063 FL
ECM250/063 FB

Motori / Motors IP66 → 18

ECM

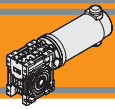

Dimensioni

Dimensions

ECM350/030 U

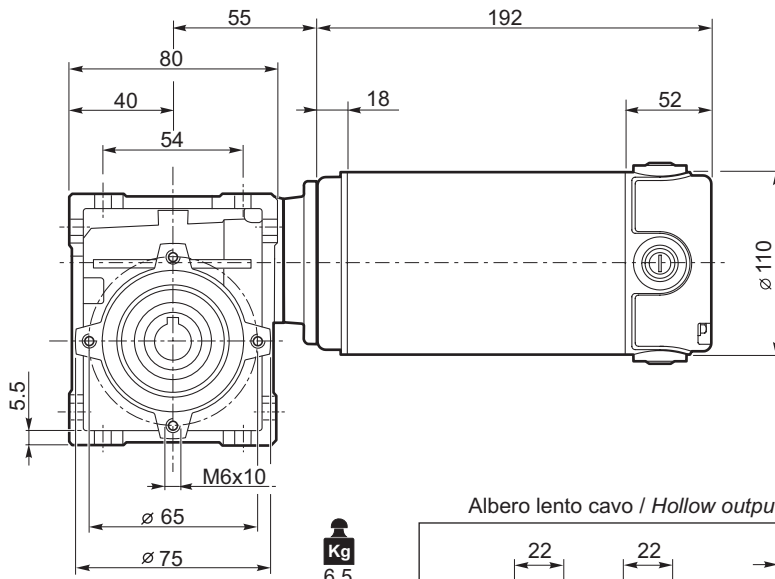

Kg
6.5

Albero lento cavo / Hollow output shaft

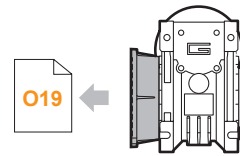
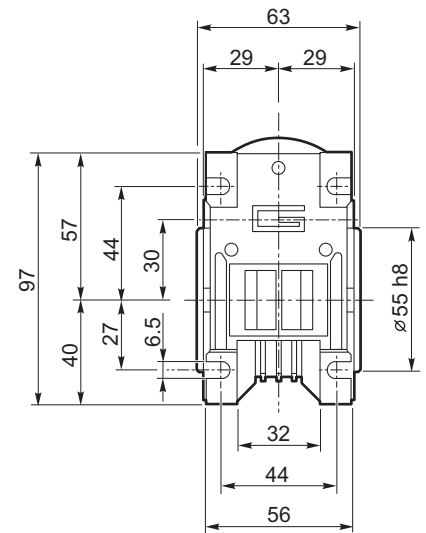
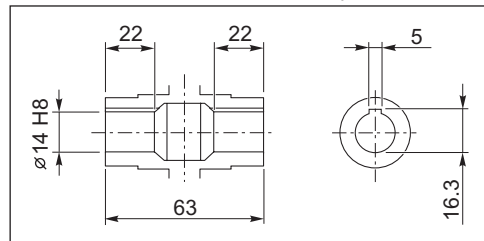

ECM350/030 F

Motori / Motors IP66



Freno / Brake



ECM350/040 U

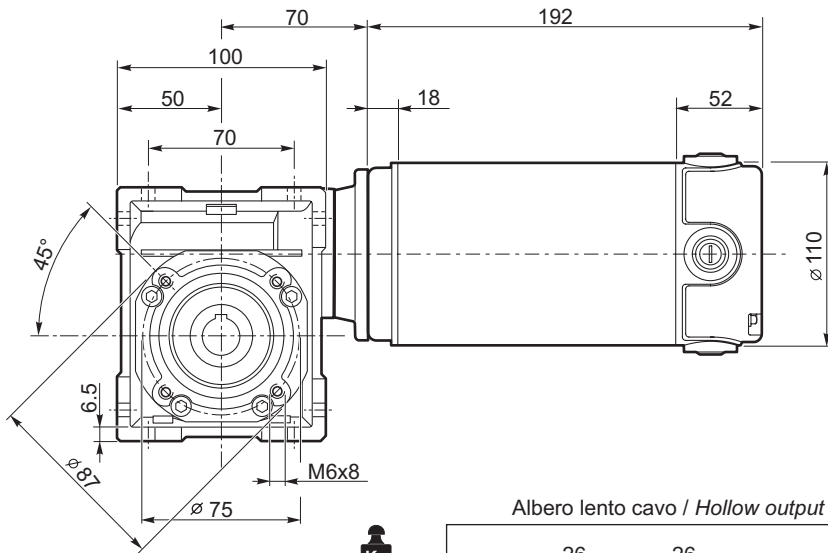

Kg
7.6

Albero lento cavo / Hollow output shaft

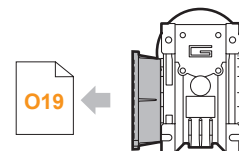
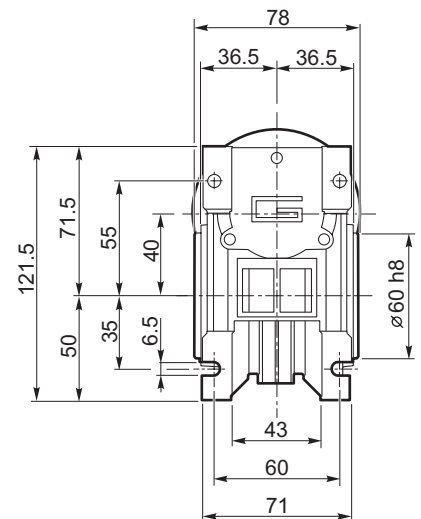
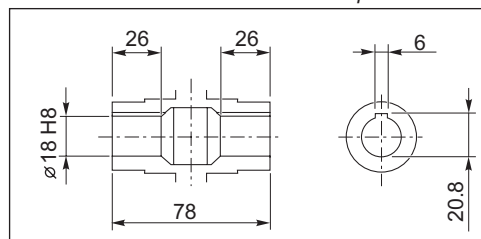

ECM350/040 F
ECM350/040 FL
ECM350/040 FB

Motori / Motors IP66



Freno / Brake





Dimensioni

Dimensions

ECM350/050 U

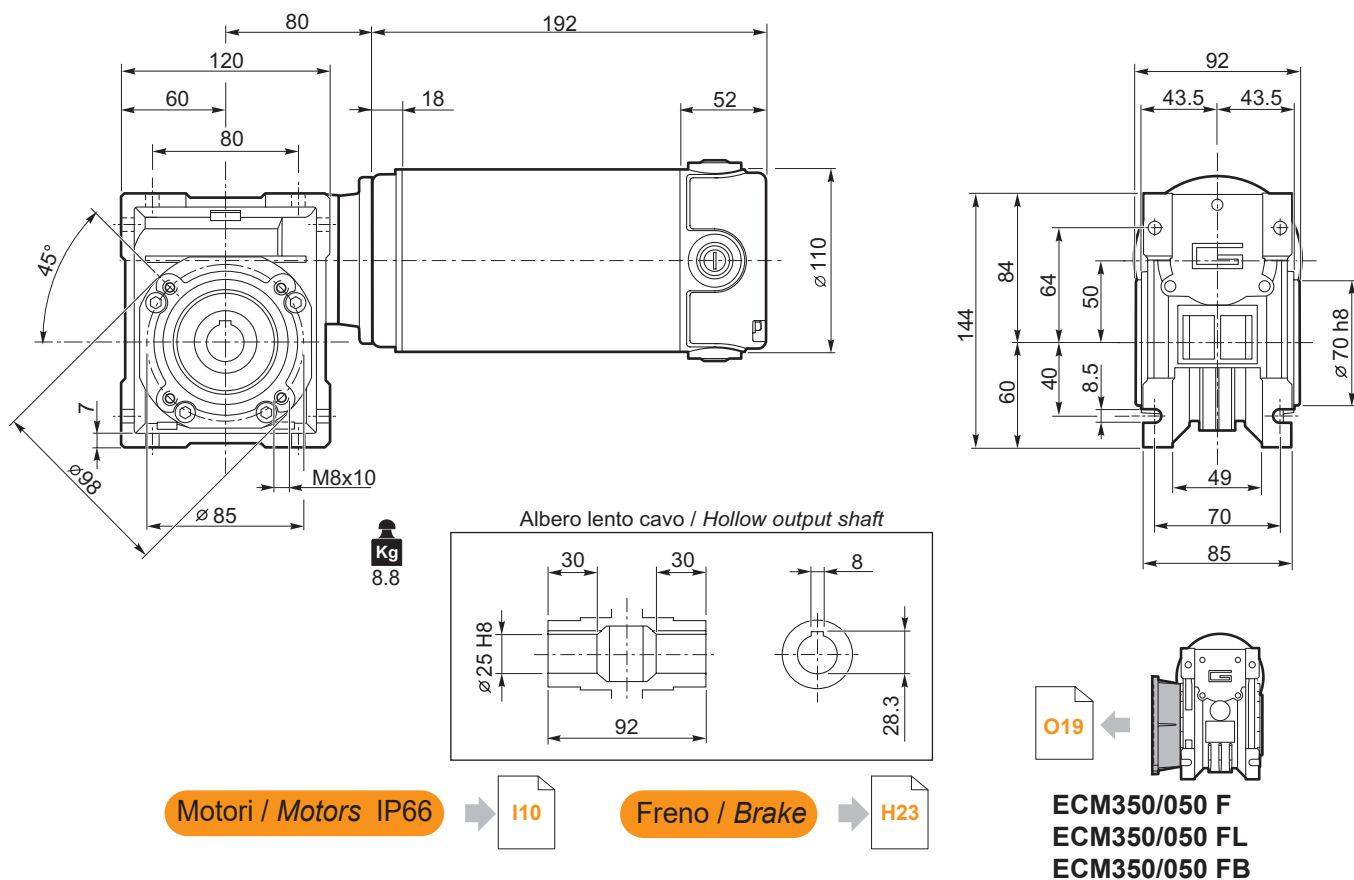

ECM350/063 U

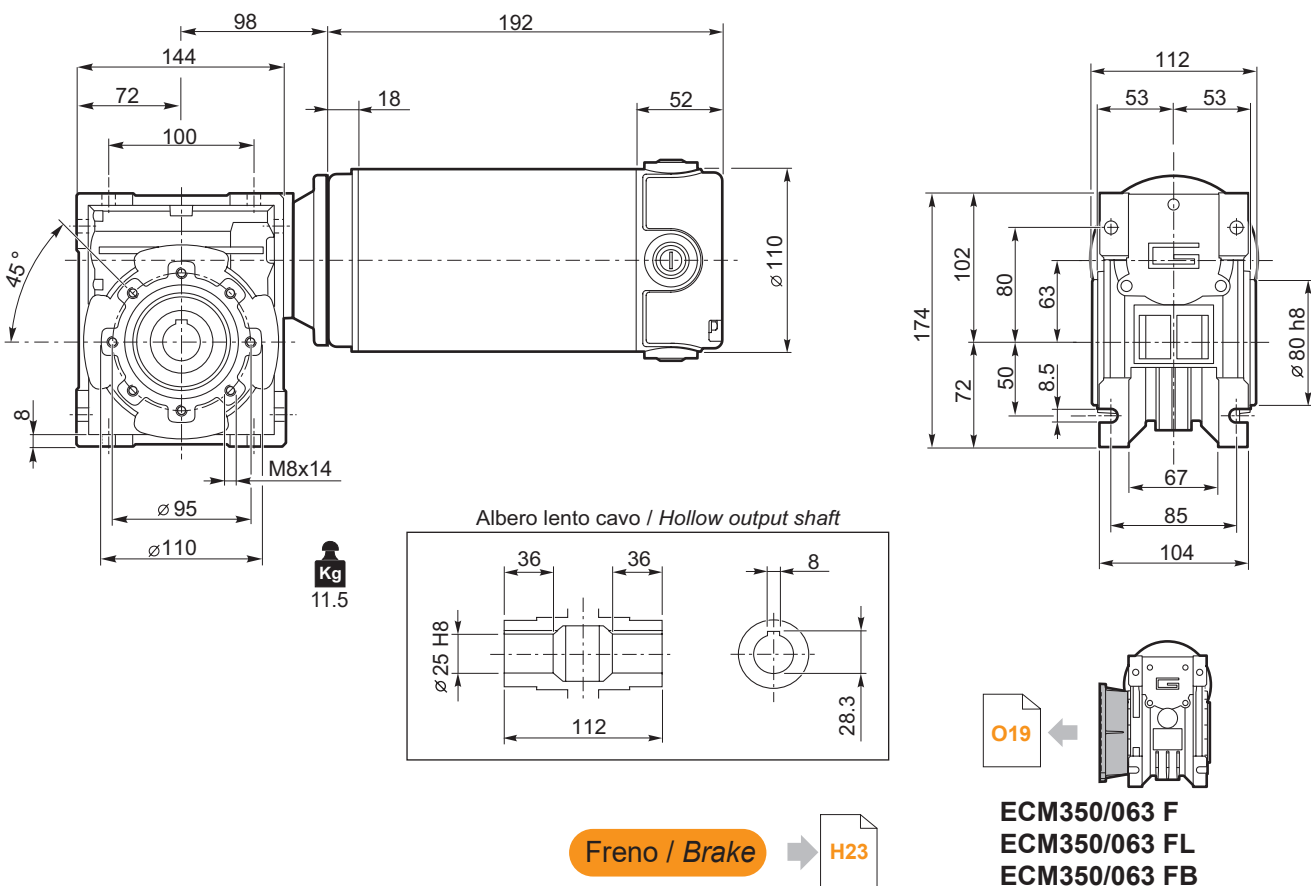

ECM

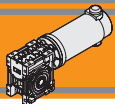

Dimensioni

Dimensions

ECM350/070 U

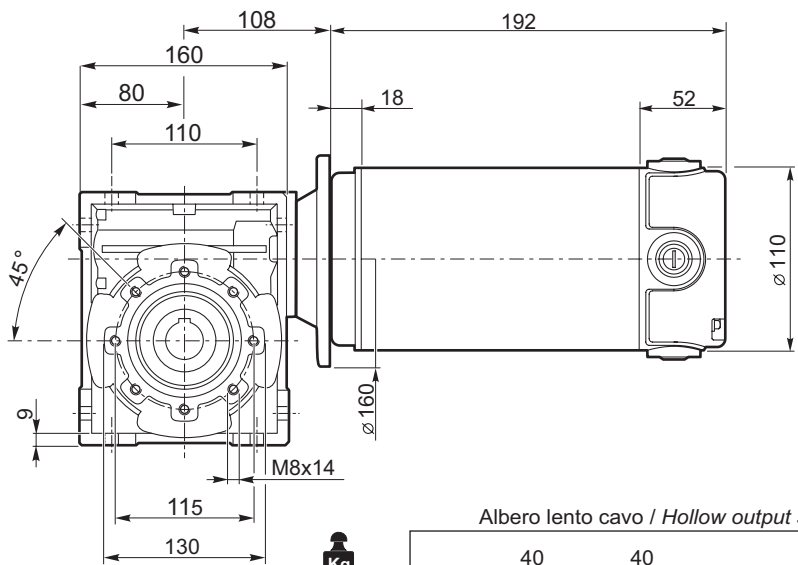

Kg
12.8

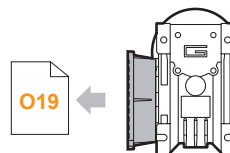
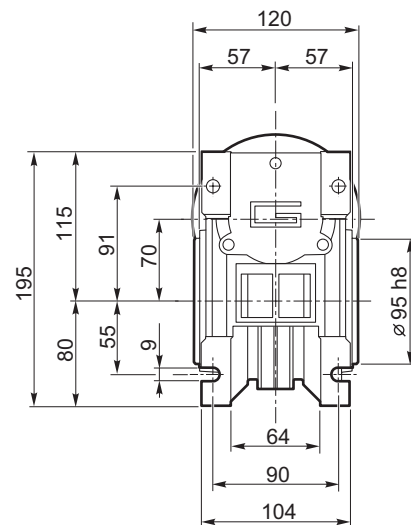
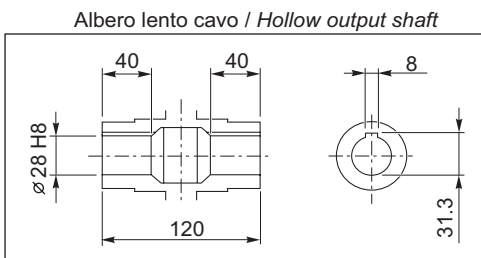

ECM350/070 F

Freno / Brake → **H23**



Dimensioni

Dimensions

ECM600/040 U

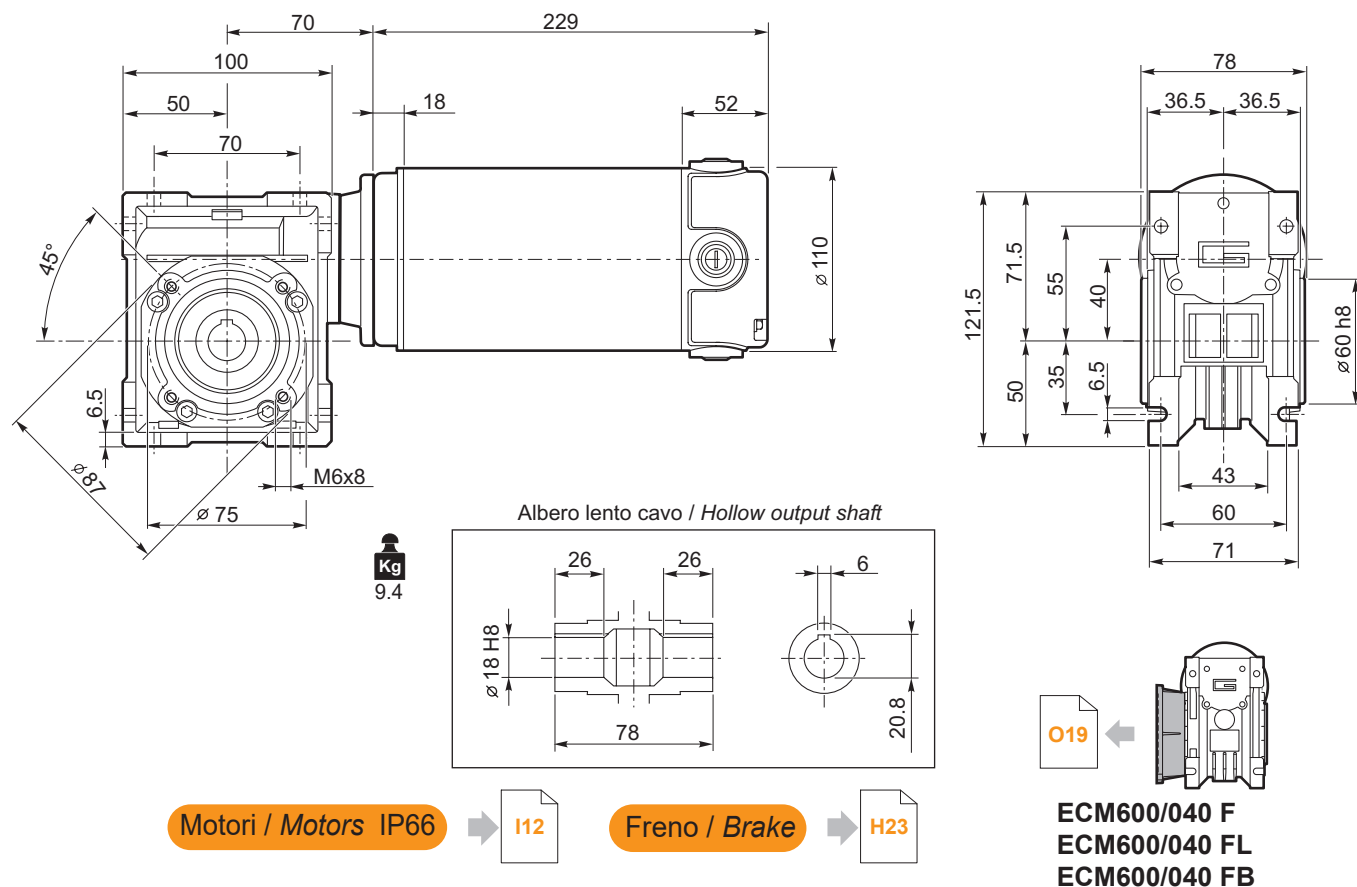

ECM600/050 U

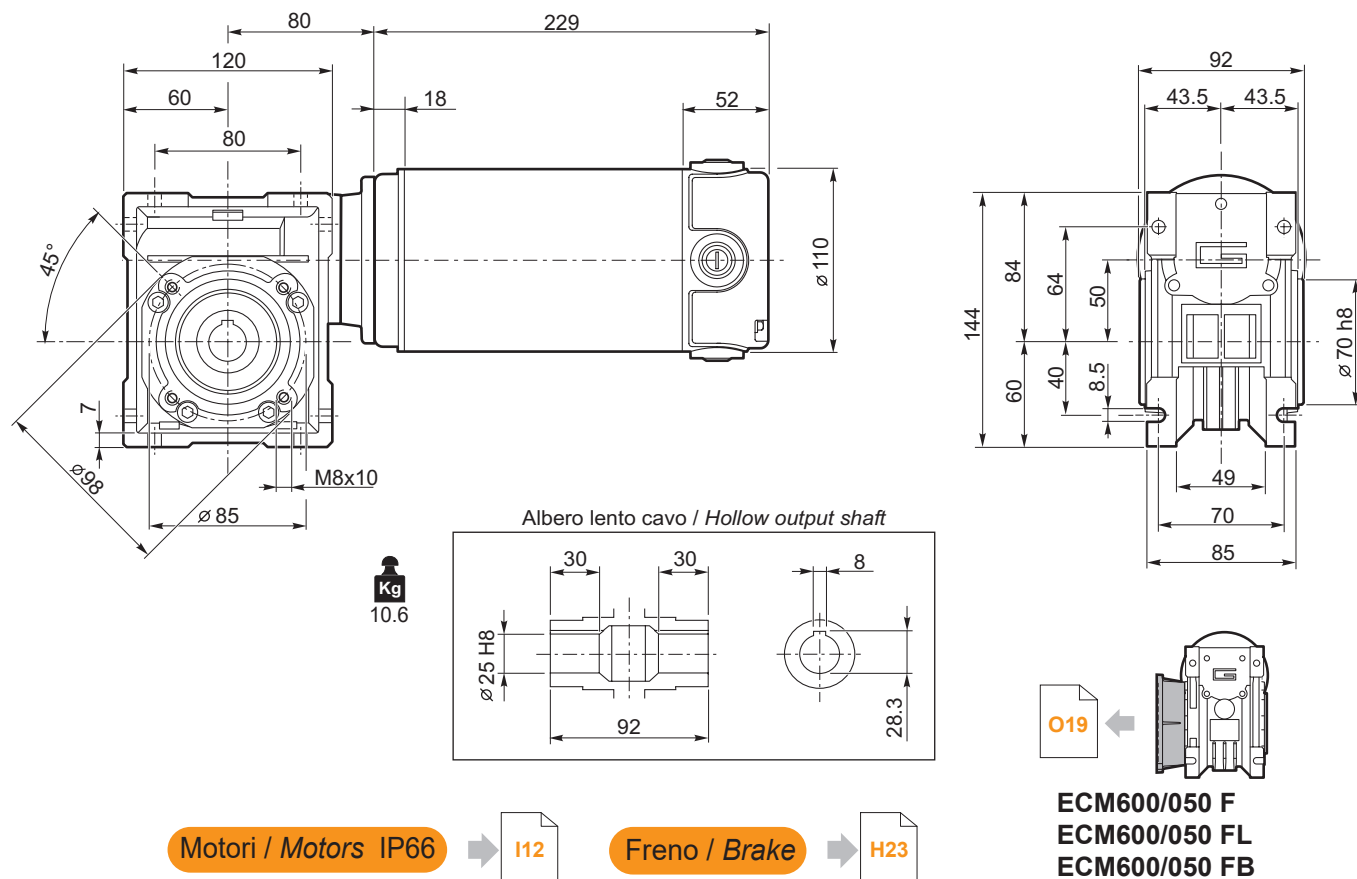

ECM

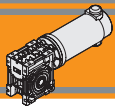

Dimensioni

Dimensions

ECM600/063 U

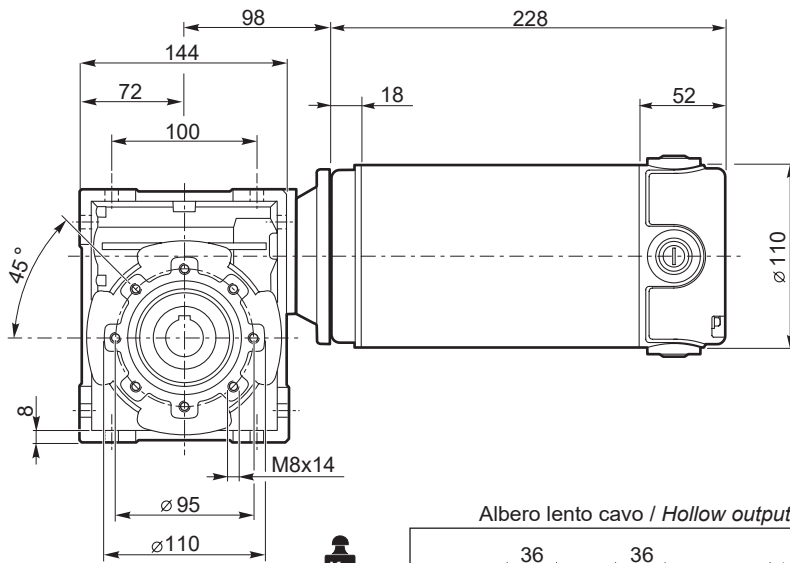

Kg
13.3

Albero lento cavo / Hollow output shaft

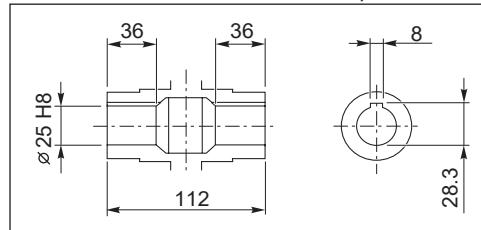

Motori / Motors IP66



Freno / Brake

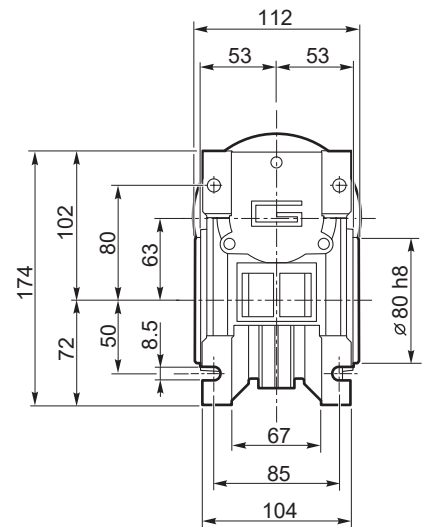

O19

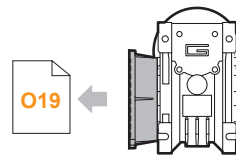

ECM600/063 F
ECM600/063 FL
ECM600/063 FB

ECM600/070 U

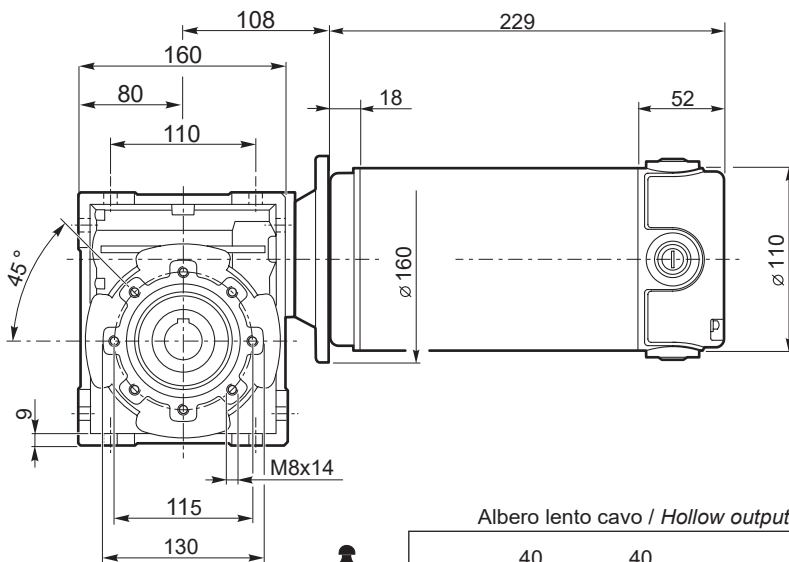

Kg
14.6

Albero lento cavo / Hollow output shaft

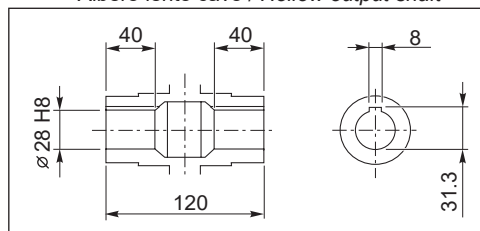

Freno / Brake

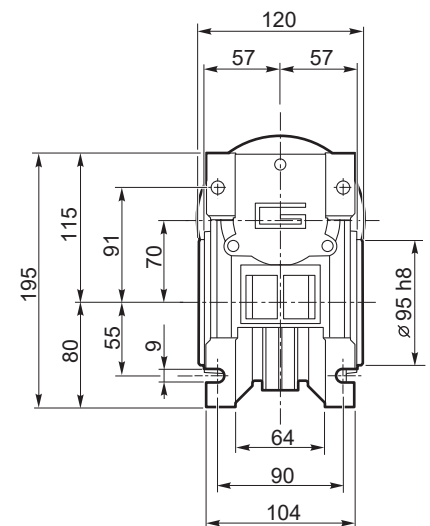

O19

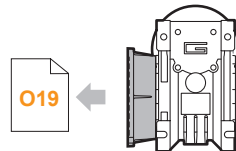

ECM600/070 F



Dimensioni

Dimensions

ECM.../... F... Flange uscita / Output flanges

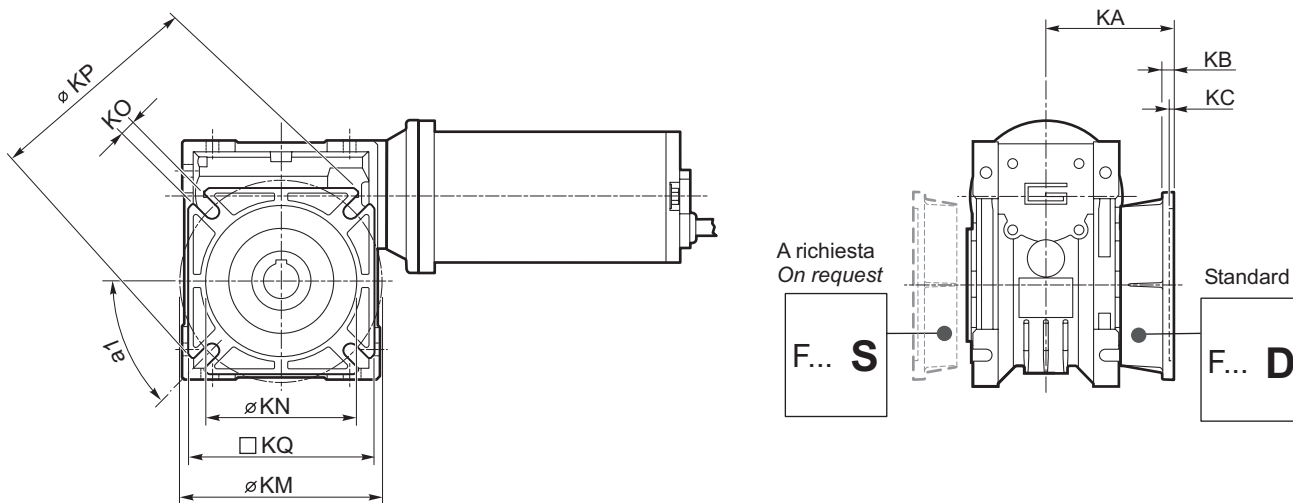

	CM..F							CM..F28							CM..F30										
	a1	KA	KB	KC	KM	KN _{H8}	KO	KP	KQ	KA	KB	KC	KM	KN _{H8}	KO	KP	KQ	KA	KB	KC	KM	KN _{H8}	KO	KP	KQ
026 (D11) 026 026 (D14)	45°	45	6	4.5	55-69	40	6.5(n.4)	75	70	44	6.5	5	56-64	40	6.5	70	60	48	6.5	5	68	50	6.5	80	70

CM	CM..F							CM..FB							CM..FL										
	a1	KA	KB	KC	KM	KN _{H8}	KO	KP	KQ	KA	KB	KC	KM	KN _{H8}	KO	KP	KQ	KA	KB	KC	KM	KN _{H8}	KO	KP	KQ
030	45°	54.5	6	4	68	50	6.5(n.4)	80	70	—	—	—	—	—	—	—	—	—	—	—	—	—	—	—	—
040	45°	67	7.5	4	80-95	60	9(n.4)	110	95	80	8.5	5	115-125	95	9.5(n.4)	140	112	97	7.5	4.5	80-95	60	9(n.4)	110	95
050	45°	90	9	5	90-110	70	11(n.4)	125	110	89	9	5	130-145	110	9.5(n.4)	160	132	120	9	5	90-110	70	11(n.4)	125	110
063	45°	82	10	6	150-160	115	11(n.4)	180	142	98	10	5	165-180	130	11(n.4)	200	160	112	10	6	150-160	115	11(n.4)	180	142
070	45°	107	13	6	165-180	130	14(n.4)	200	170	—	—	—	—	—	—	—	—	—	—	—	—	—	—	—	—

EC100.24E
EC180.24E

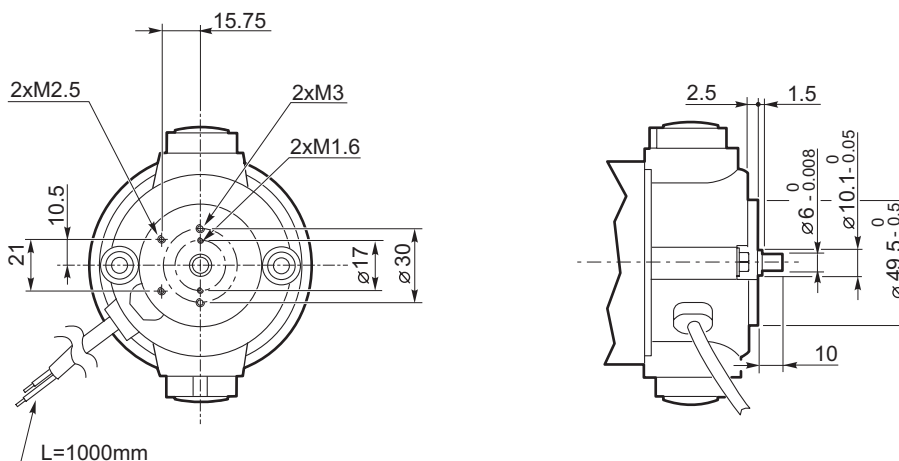

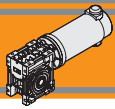

Opzioni

Options

VS - Vite sporgente / Extended input shaft

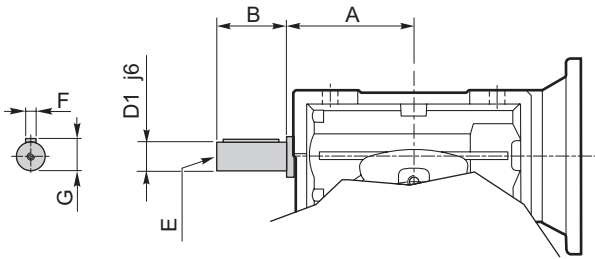

	A	B	D ₁ j6	E	F	G
CM 030	45	20	9	M4	3	10.2
CM 040	53	23	11	M5	4	12.5
CM 050	64	30	14	M6	5	16
CM 063	75	40	19	M6	6	21.5
CM 070	84	40	19	M6	6	21.5

Costruito su richiesta
Built on request

SC - Safety cover

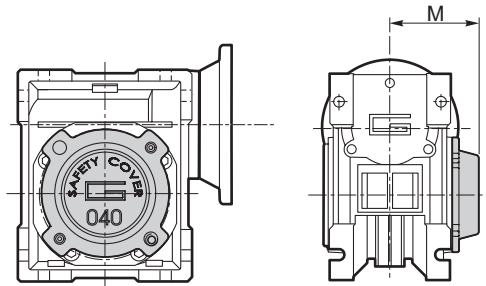

	M
CM 030	47
CM 040	54.5
CM 050	62.5
CM 063	73
CM 070	75

Accessori

Accessories

Albero lento

Output shaft

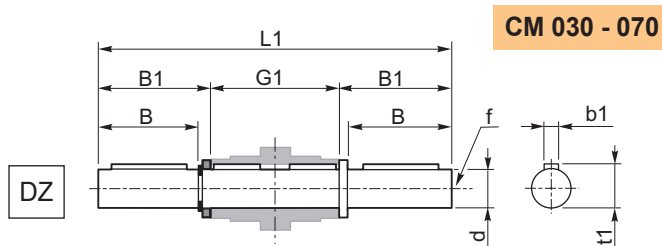

CM 030 - 070

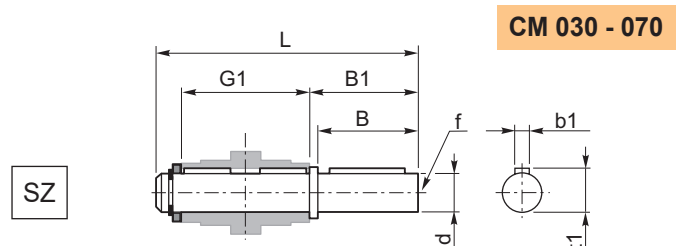

CM 030 - 070

	d h7	B	B1	G1	L	L1	f	b1	t1
CM 030	14	30	32.5	63	102	128	M6	5	16
CM 040	18	40	43	78	128	164	M6	6	20.5
CM 050	25	50	53.5	92	153	199	M10	8	28
CM 063	25	50	53.5	112	173	219	M10	8	28
CM 070	28	60	63.5	120	192	247	M10	8	31

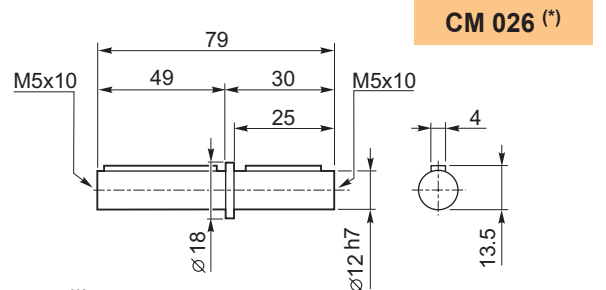

CM 026 (*)

(*)
Nota: disponibile solo per cavo uscita Ø12
Note: available for output hollow shaft Ø12 only

Braccio di reazione

Torque arm

	K1	G	KG	KH	R
CM 030	85	14	23	8	15
CM 040	100	14	31	10	18
CM 050	100	14	38	10	18
CM 063	150	14	47.5	10	18
CM 070	200	25	46.5	20	30

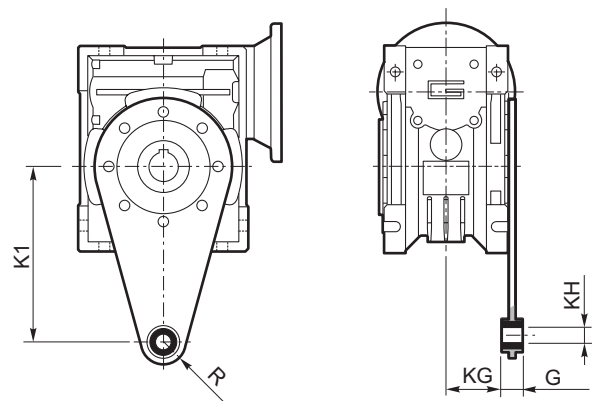



Ferrite

Motoriduttori CC a vite senza fine con precoppia
DC pre stage wormgearmotors

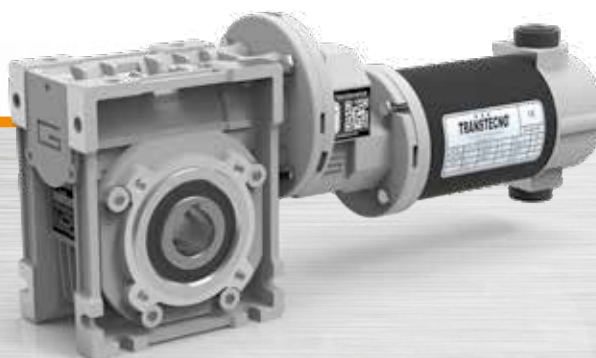

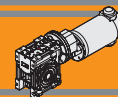

Indice	Index	Pag. Page
Caratteristiche tecniche	<i>Technical features</i>	P2
Designazione	<i>Classification</i>	P2
Simbologia	<i>Symbols</i>	P3
Lubrificazione	<i>Lubrication</i>	P3
Carichi radiali	<i>Radial loads</i>	P3
Dati tecnici per servizio S2	<i>Technical data for S2 duty</i>	P4
Motori applicabili	<i>Motor adapters</i>	P5
Dimensioni	<i>Dimensions</i>	P6
Opzioni	<i>Options</i>	P19
Accessori	<i>Accessories</i>	P19

Questa sezione annulla e sostituisce ogni precedente edizione o revisione. Qualora questa sezione non Vi sia giunta in distribuzione controllata, l'aggiornamento dei dati ivi contenuto non è assicurato. **In tal caso la versione più aggiornata è disponibile sul nostro sito internet www.transtecno.com**

This section replaces any previous edition and revision. If you obtained this catalogue other than through controlled distribution channels, the most up to date content is not guaranteed. In this case the latest version is available on our web site www.transtecno.com

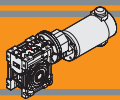

Caratteristiche tecniche

Technical features

Le caratteristiche principali dei motoriduttori CC a vite senza fine con precoppia a magneti permanenti in ferrite serie ECMP sono:

The main features of ECMP ferrite permanent magnets DC pre stage wormgearmotors range are:

- Alimentazione in bassa tensione 12/24 Vcc
- Possibilità di montaggio encoder
- Potenze motore disponibili da 100 a 800W S2
- Magneti in ferrite
- Sia le carcasse dei riduttori a vite senza fine che delle precoppie sono in pressofusione di alluminio
- Lubrificazione permanente con olio sintetico

- Low voltage power supply 12/24 Vdc
- Suitable for encoder assembly
- Motor power ratings available from 100 up to 800W S2
- Ferrite magnets
- Die-cast aluminum housing on pre-stage and wormgearboxes
- Permanent synthetic oil long-life lubrication.

Designazione

Classification

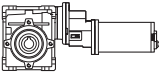
MOTORIDUTTORE / GEARMOTOR												
ECMP	070/056/030				U	90	SZDX	BR SX	90	P4	240	VS
Tipo Type	Grandezza Size				Versione Riduttore Gearbox Version	Rapporto Ratio	Albero di uscita Output shaft	Braccio di reazione Torque arm	Angolo Angle	Pos. di montag- gio precoppia Pre stage mounting position	Versione Motore Motor Version	Opzioni Options
	070/056/030	180/056/030	350/063/050	600/071/050	U	Vedere tabella See tables	SZDX SZSX DZ	BRDX BR SX *	0° 90° 180° 270°	P1 P2 P3 (standard) P4	120 240 24E	VS
	070/056/040	180/056/040	350/063/063	600/071/063	FD							
		180/063/050	350/071/063	600/071/070	FS							
		180/063/063	350/071/070	600/071/075	FLD							
	100/056/030		350/071/075		FLS							
	100/056/040	250/063/040			FBD							
	100/063/050	250/063/050			FBS							
		250/063/063										

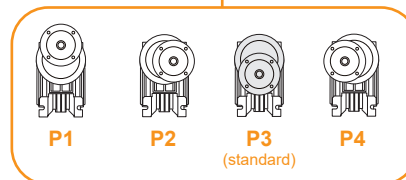

Versione Riduttore
Gearbox Version

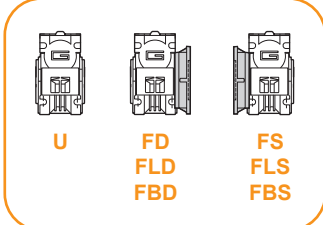

Albero di uscita
Output shaft

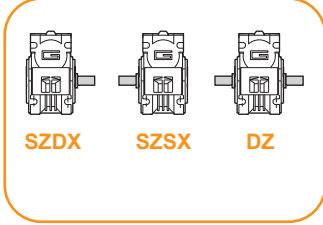

Braccio di reazione
Torque arm *

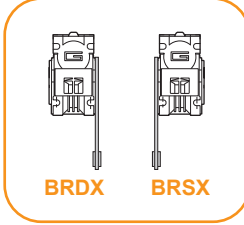

Angolo
Angle

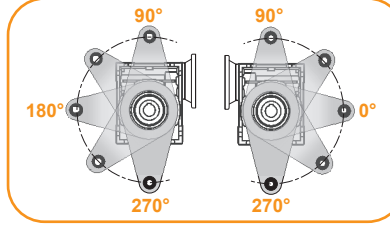

* NOTA: il braccio di reazione viene fornito smontato.
NOTE: the torque arm will be supplied not assembled.

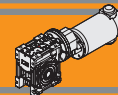

Simbologia

Symbols

n_1 [min ⁻¹]	Velocità in ingresso / <i>Input speed</i>	M_2 [Nm]	Coppia in uscita in funzione di P_1 / <i>Output torque referred to P_1</i>
n_2 [min ⁻¹]	Velocità in uscita / <i>Output speed</i>	sf	Fattore di servizio / <i>Service factor</i>
i	Rapporto di riduzione / <i>Ratio</i>	R_2 [N]	Carico radiale ammissibile in uscita / <i>Permitted output radial load</i>
P_1 [kW]	Potenza in entrata / <i>Input power</i>	A_2 [N]	Carico assiale ammissibile in uscita / <i>Permitted output axial load</i>

Lubrificazione

Lubrication

I riduttori a vite senza fine con precoppia della serie CMP sono lubrificati a vita con olio sintetico di viscosità 320 e possono essere installati in qualunque posizione di montaggio.

Permanent synthetic oil long - life lubrication allow to use CMP range in all mounting positions.

Carichi radiali

Radial loads

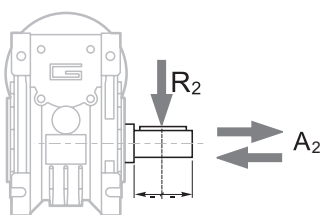

n_2 [min ⁻¹]	R_2 [N]					
	CM030	CM040	CM050	CM063	CM070	CM075
35	1179	2210	3095	4273	4568	4937
28	1270	2381	3334	4603	4921	5318
23	1356	2542	3559	4915	5254	5678
18	1471	2759	3862	5334	5702	6162
14	1600	3000	4200	5800	6200	6700

Quando il carico radiale risultante non è applicato sulla mezzesfera dell'albero occorre calcolare quello effettivo con la seguente formula:

When the resulting radial load is not applied on the centre line of the shaft it is necessary to calculate the effective load with the following formula:

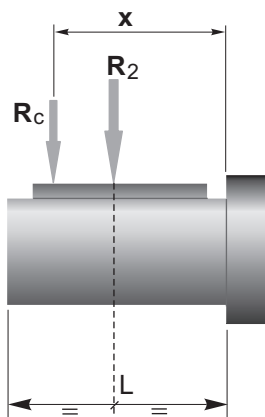

$$R_c = \frac{R_2 \cdot a}{(b+x)} \leq R_{2MAX}$$

$$R \leq R_c$$

a, b = valori riportati nella tabella
a, b = values given in the table

	CM					
	030	040	050	063	070	075
a	65	84	101	120	122	131
b	50	64	76	95	92	101
R_{2MAX}	1600	3000	4200	5800	6200	6700

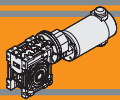

Dati tecnici per servizio S2

Technical data for S2 duty

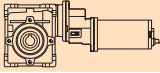
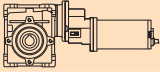
P_1 [W]	n_2 [min ⁻¹]	M_2 [Nm]	sf	i		Versione motore Motor version	P_1 [W]	n_2 [min ⁻¹]	M_2 [Nm]	sf	i		Versione motore Motor version
100							350						
(3000 min ⁻¹)	50	13	1.7	60	ECMP070/056/030	12E/24E	(3000 min ⁻¹)	50	48	0.9	60	ECMP250/063/040	120/240
	40	16	1.4	75				40	57	0.8	75		
	33	17	1.6	90				33	65	0.9	90		
	25	22	1.1	120				25	69	0.7	120		
	20	25	0.9	150				50	49	1.6	60		
	50	14	3.2	60	ECMP070/056/040	12E/24E		50	49	1.6	60	ECMP250/063/050	120/240
	40	16	2.7	75				40	59	1.3	75		
	33	19	3.0	90				33	67	1.5	90		
	25	22	2.1	120				25	81	1.0	120		
	20	27	1.7	150				20	97	0.8	150		
	17	30	1.4	180	17	108		0.7	180				
	13	34	1.2	240	13	99		0.7	240				
	10	38	0.9	300	50	51		3.0	60	ECMP250/063/063	120/240		
	50	19	1.2	60	ECMP100/056/030	120/240/24E		40	61			2.2	75
	40	22	1.0	75				33	69			2.7	90
33	24	1.1	90	25			85	1.9	120				
25	30	0.8	120	20			100	1.5	150				
20	31	0.7	150	17			114	1.2	180				
50	19	2.3	60	ECMP100/056/040	120/240/24E	13	136	0.9	240				
40	23	1.9	75			10	154	0.8	300				
33	26	2.2	90			50	70	1.1	60				
25	31	1.5	120			40	84	0.9	75				
20	37	1.2	150			33	95	1.0	90				
17	42	1.0	180	25	116	0.7	120						
13	48	0.8	240	20	116	0.7	150						
10	54	0.7	300	17	109	0.7	180						
50	20	4.1	60	ECMP100/063/050	120/240/24E	13	99	0.7	240				
40	24	3.2	75			50	73	2.1	60				
33	27	3.7	90			40	88	1.6	75				
25	32	2.6	120			33	98	1.9	90				
20	39	2.1	150			25	122	1.3	120				
17	43	1.8	180	20	143	1.1	150						
13	50	1.4	240	17	163	0.9	180						
50	33	0.7	60	ECMP180/056/030	120/240	13	195	0.7	240				
40	31	0.7	75			10	174	0.7	300				
33	39	0.7	90			50	73	2.1	60				
25	33	0.7	120			40	88	1.6	75				
20	31	0.7	150			33	98	1.9	90				
50	35	1.3	60	ECMP180/056/040	120/240	25	122	1.3	120				
40	41	1.1	75			20	143	1.1	150				
33	46	1.2	90			17	163	0.9	180				
25	56	0.9	120			50	74	3.1	60				
20	67	0.7	150			40	90	2.2	75				
17	61	0.7	180	33	101	2.7	90						
13	57	0.7	240	25	125	1.9	120						
10	51	0.7	300	20	147	1.5	150						
50	35	2.3	60	ECMP180/063/050	120/240/24E	17	168	1.3	180				
40	42	1.8	75			13	202	0.9	240				
33	48	2.1	90			10	229	0.7	300				
25	58	1.5	120			50	75	3.7	60				
20	69	1.2	150			40	90	2.7	75				
17	77	1.0	180	33	102	3.2	90						
13	90	0.8	240	25	127	2.3	120						
50	37	4.2	60	ECMP180/063/063	120/240/24E	20	150	1.7	150				
40	44	3.1	75			17	168	1.5	180				
33	49	3.8	90			13	206	1.1	240				
25	61	2.6	120			10	234	0.9	300				
20	71	2.1	150			50	75	3.7	60				
17	81	1.7	180	40	90	2.7	75						
13	97	1.3	240	33	102	3.2	90						
10	110	1.1	300	25	127	2.3	120						
				20	150	1.7	150						
				17	168	1.5	180						
				13	206	1.1	240						
				10	234	0.9	300						

NOTA

Verificare sempre che la coppia M_2 utilizzata non ecceda il valore indicato nelle caselle in grigio

NOTE

Please check that the output torque M_2 does not exceed the value in the grey areas

NOTA: per servizio continuo o altamente intermittente, contattare il servizio tecnico

NOTE: for continuous or highly intermittent duty, please contact our technical service

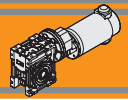

Dati tecnici per servizio S2

Technical data for S2 duty

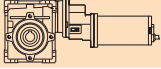
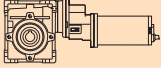
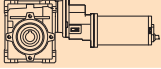
P_1 [W]	n_2 [min ⁻¹]	M_2 [Nm]	sf	i		Versione motore Motor version
800						
(3000 min ⁻¹)	50	112	0.7	60		ECMP600/071/050
	40	107	0.7	75		
	33	141	0.7	90		
	50	117	1.3	60		ECMP600/071/063
	40	140	1.0	75		
	33	157	1.2	90		
	25	195	0.8	120		
	20	228	0.7	150		
	17	203	0.7	180		

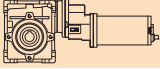
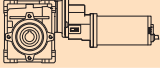
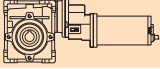
P_1 [W]	n_2 [min ⁻¹]	M_2 [Nm]	sf	i		Versione motore Motor version
800						
(3000 min ⁻¹)	50	118	1.9	60		ECMP600/071/070
	40	144	1.4	75		
	33	162	1.7	90		
	25	201	1.2	120		ECMP600/071/075
	20	236	0.9	150		
	17	270	0.8	180		
	50	118	2.3	60		
	40	144	1.7	75		
	33	164	2.0	90		
25	204	1.4	120			
20	240	1.1	150			
17	270	0.9	180			
13	329	0.7	240			
10	293	0.7	300			

N.B.
Verificare sempre che la coppia M2 utilizzata non ecceda il valore indicato nelle caselle in grigio
N.B.
Please check that the output torque M2 does not exceed the value in the grey areas

NOTA: per servizio continuo o altamente intermittente, contattare il servizio tecnico
NOTE: for continuous or highly intermittent duty, please contact our technical service

Motori applicabili

Motor adapters

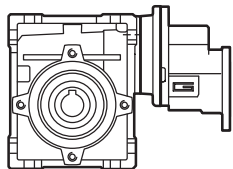
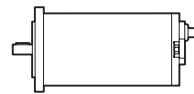

		EC						
		070.12E 070.24E	100.120 100.240 100.24E	180.120 180.240	180.24E	250.120 250.240	350.120 350.240	600.120 600.240
CMP	056/030	150	150	150				
	056/040	300	300	300				
	063/040					120		
	063/050		240	240	240	240	240	
	063/063			300	300	300	300	
	071/050							90
	071/063						180	180
	071/070						300	180
	071/075						300	300

150

Rapporto di riduzione massimo i_{max}
Maximum ratio i_{max}

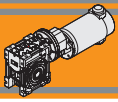

Dimensioni

Dimensions

ECMP070/056/030 U

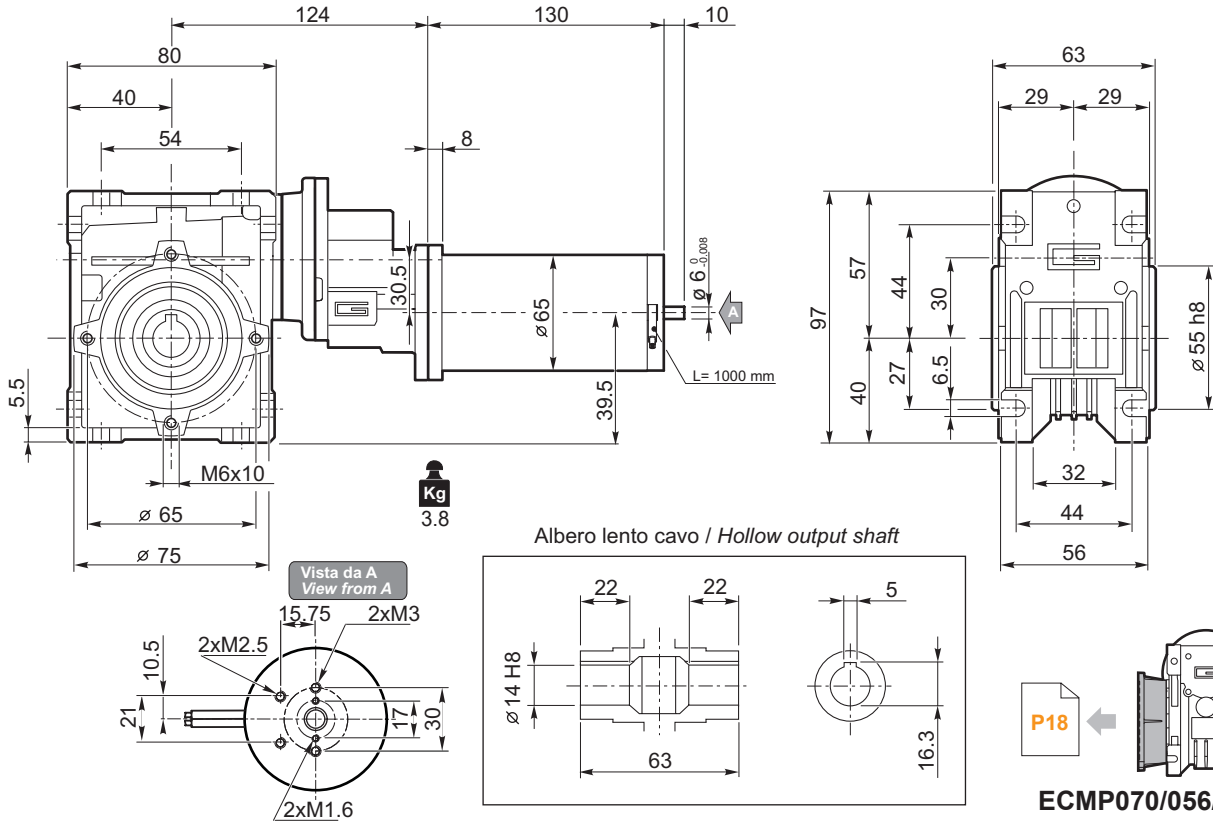

Motors / Motors IP66 → I2 Freno / Brake → H23 Encoder → H24

ECMP070/056/040 U

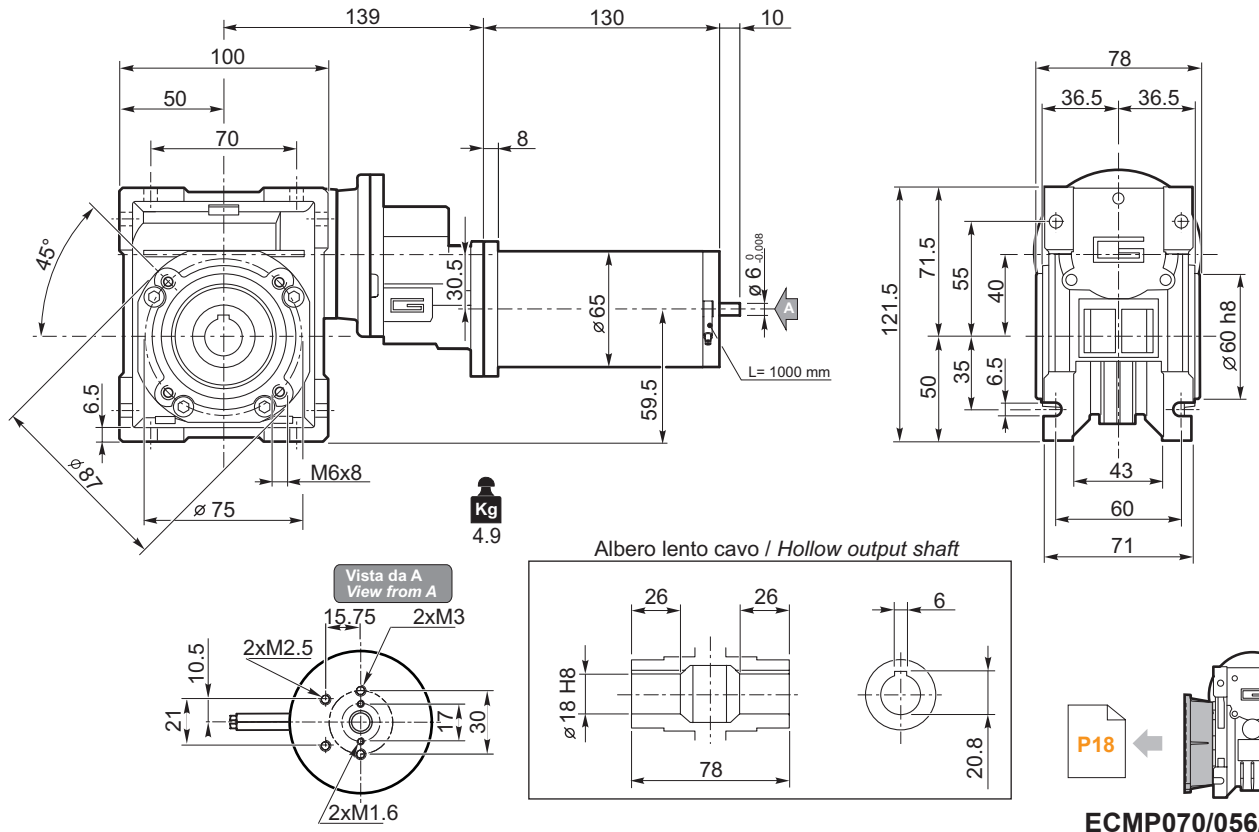

Motors / Motors IP66 → I2 Freno / Brake → H23 Encoder → H24

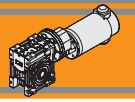

Dimensioni

Dimensions

ECMP100/056/030 U

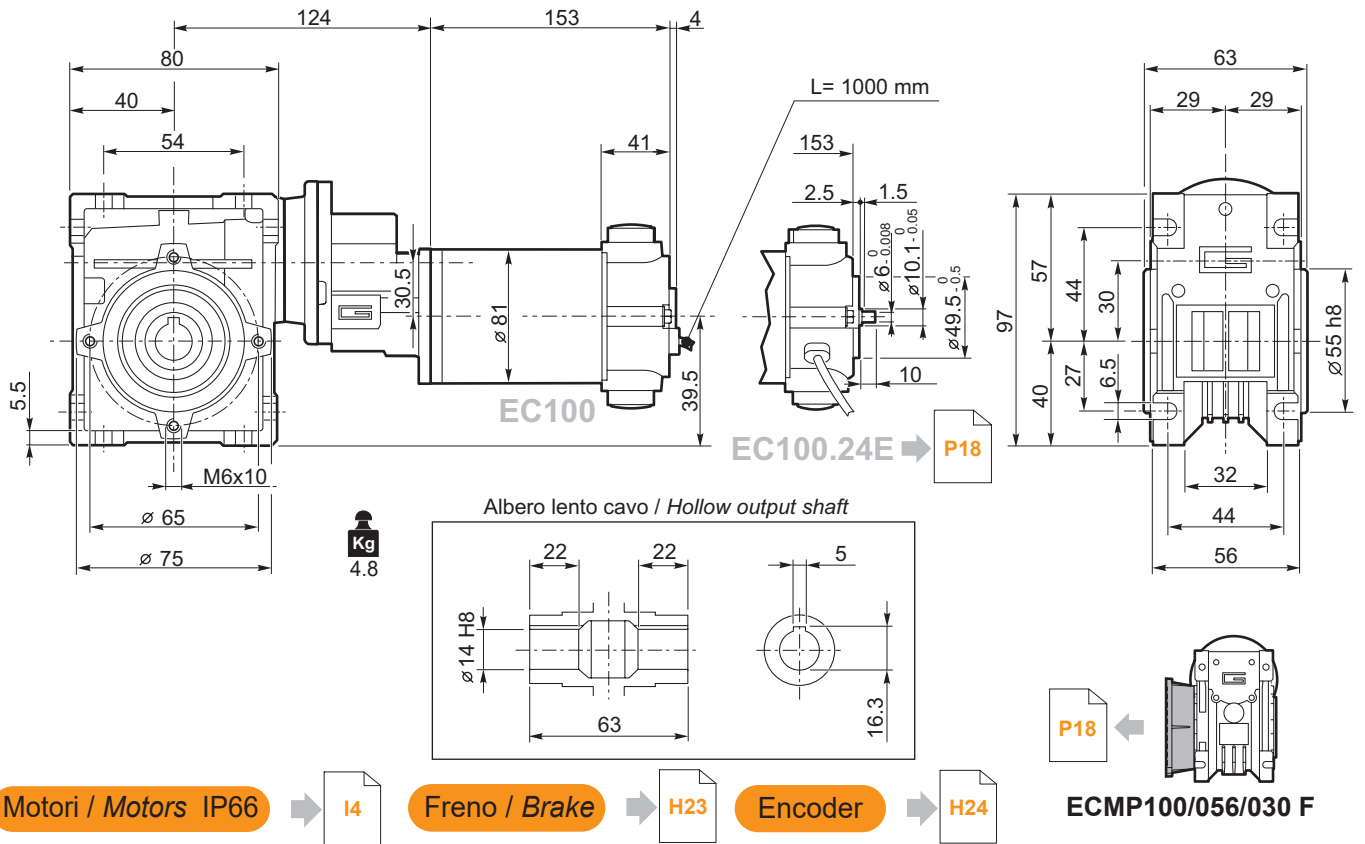

ECMP100/056/040 U

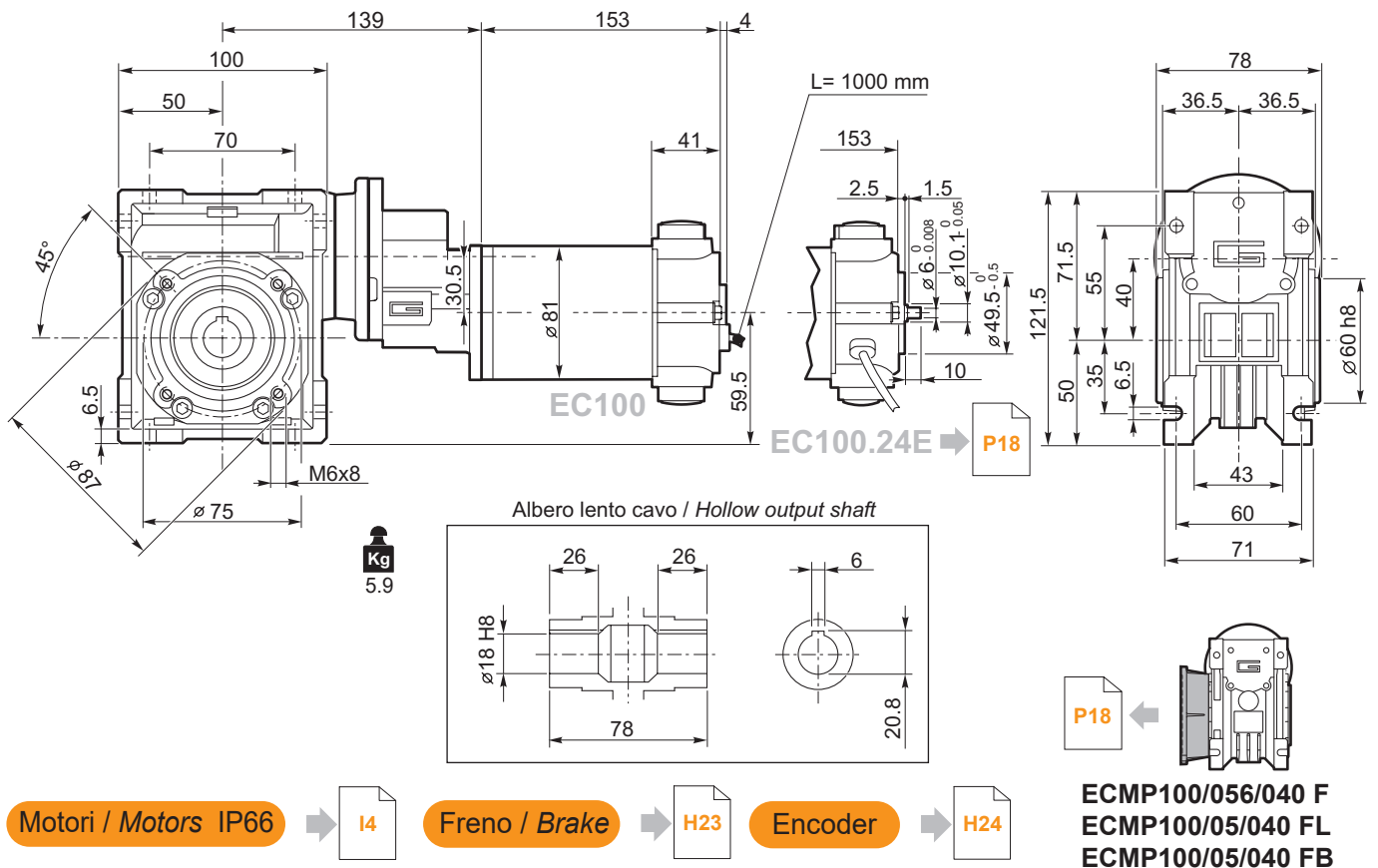

ECMP

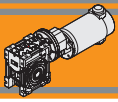

Dimensioni

Dimensions

ECMP100/063/050 U

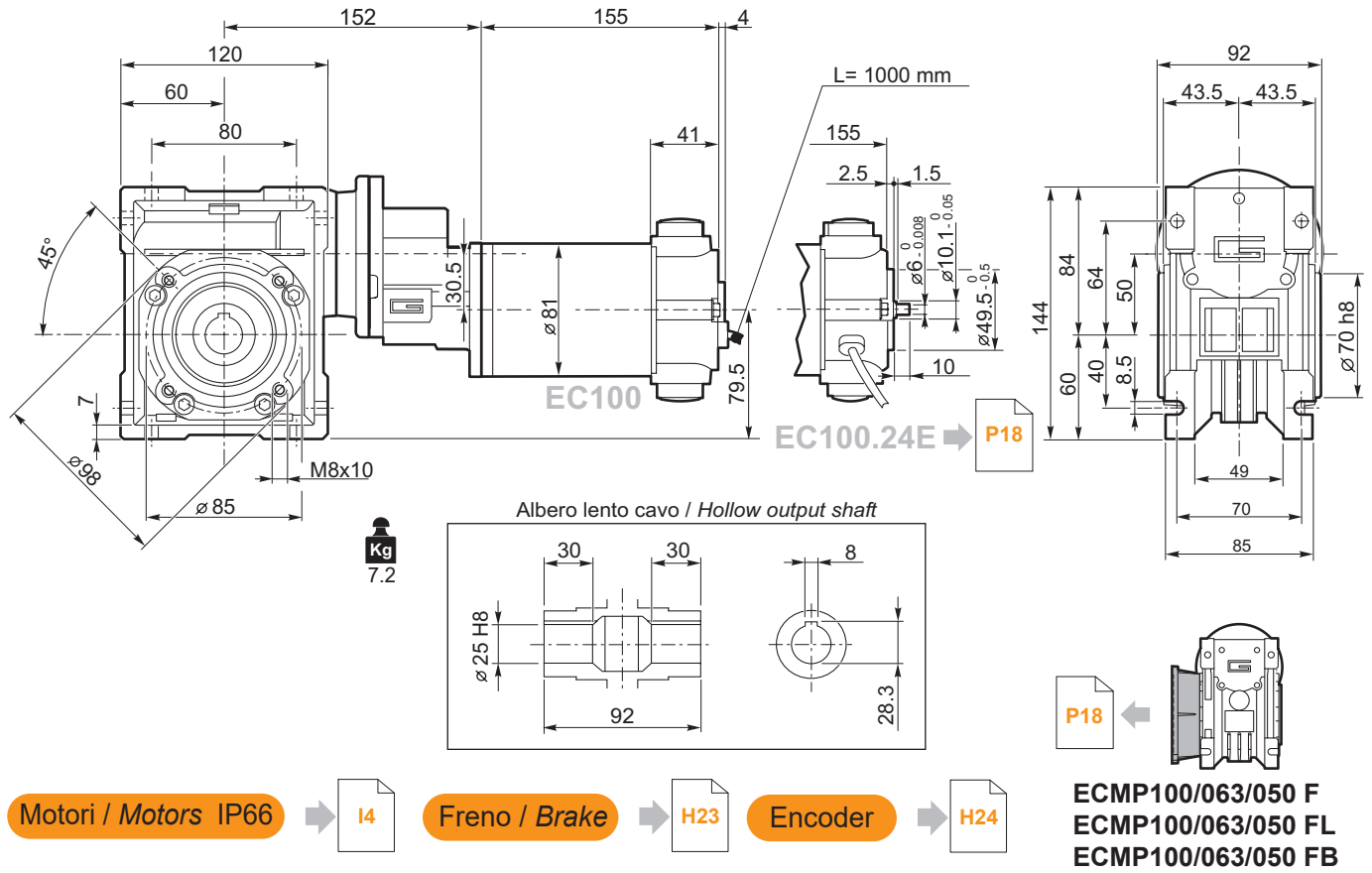

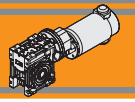

Dimensioni

Dimensions

ECMP180/056/030 U

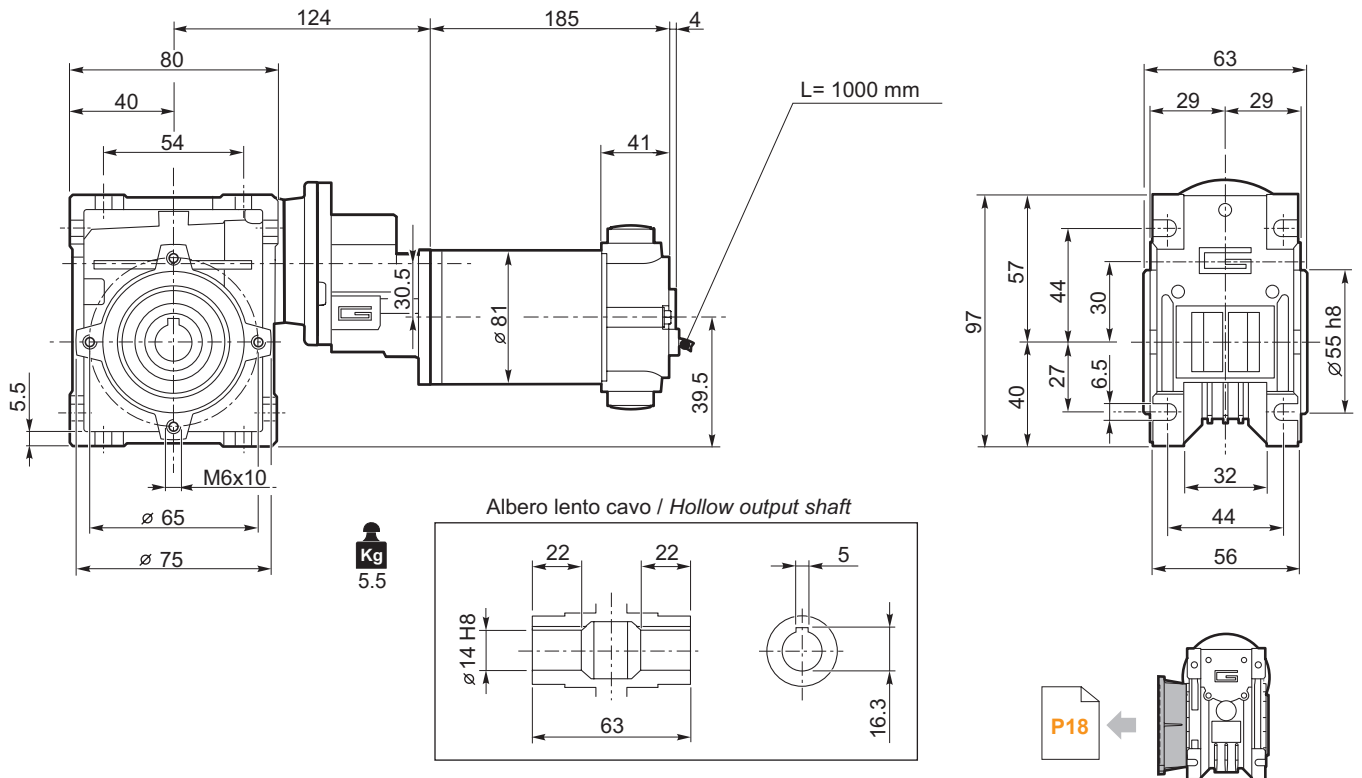

Motori / Motors IP66

I6

Freno / Brake

H23

Encoder

H24

ECMP180/056/030 F

ECMP180/056/040 U

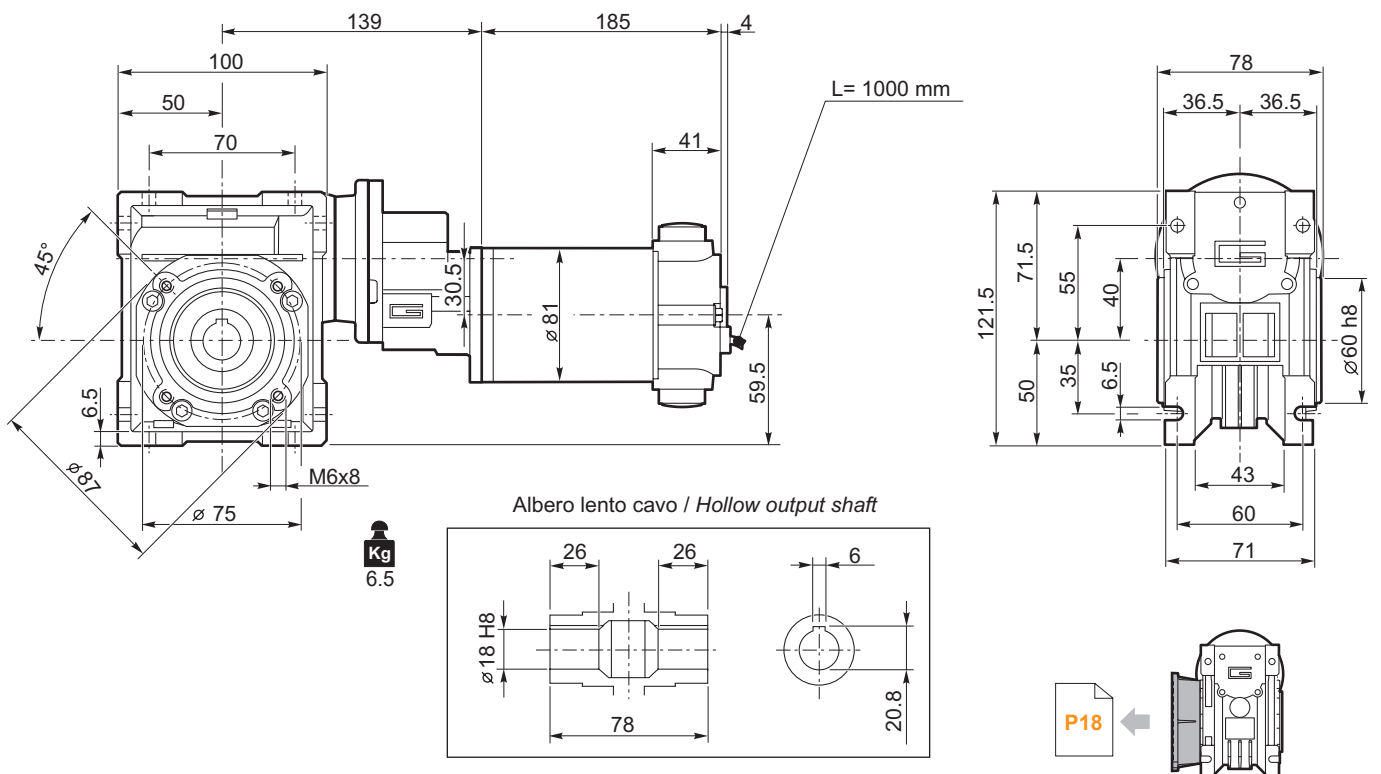

Motori / Motors IP66

I6

Freno / Brake

H23

Encoder

H24

ECMP180/056/040 F
ECMP180/056/040 FL
ECMP180/056/040 FB

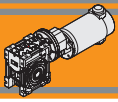

Dimensioni

Dimensions

ECMP180/063/050 U

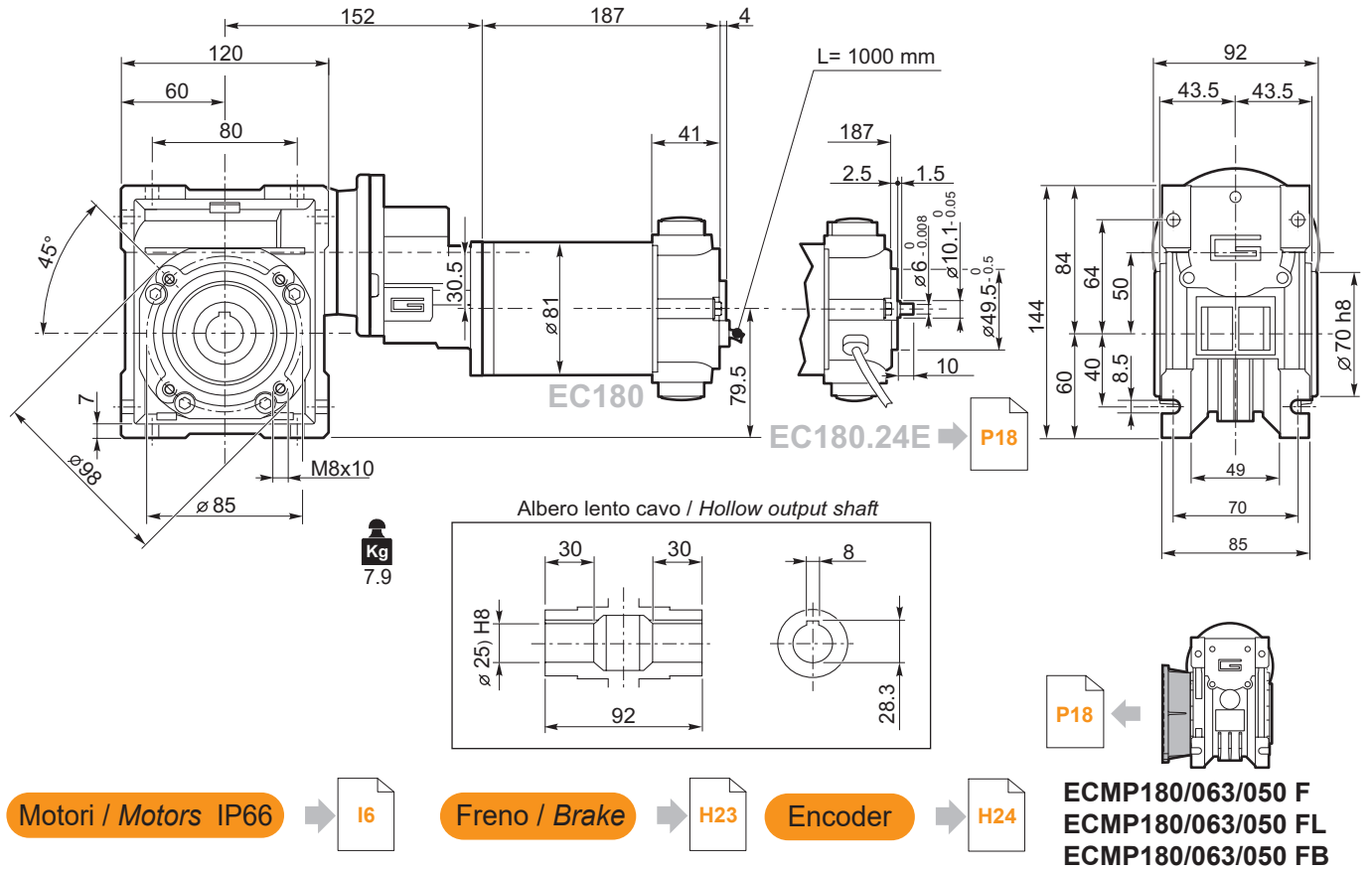

ECMP180/063/063 U

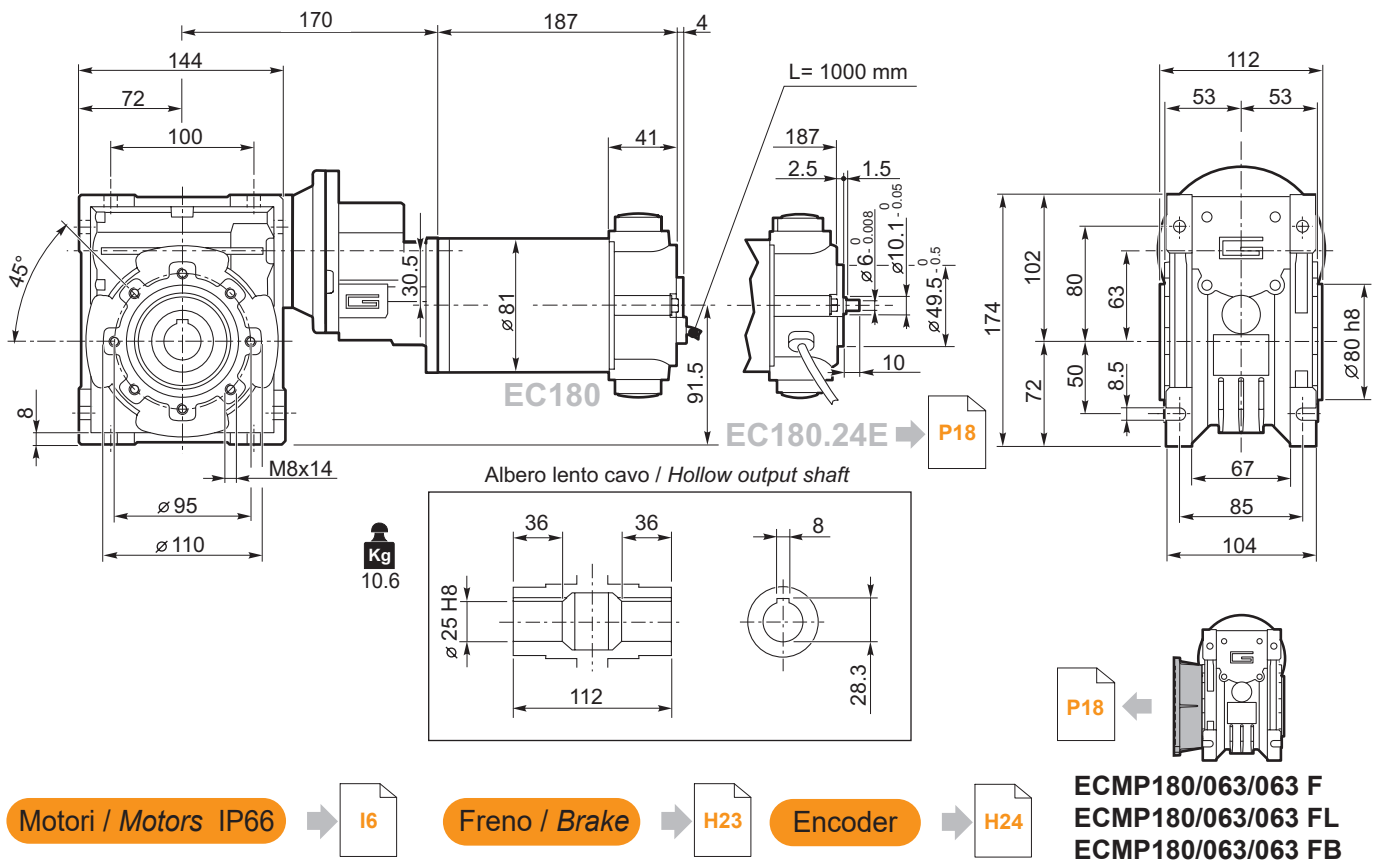

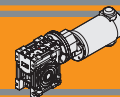

Dimensioni

Dimensions

ECMP250/063/040 U

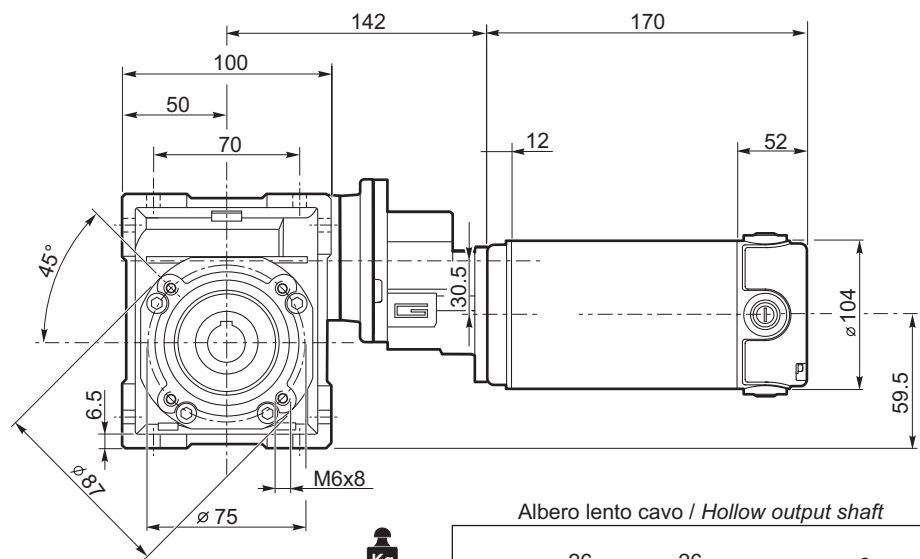

Kg
7.5

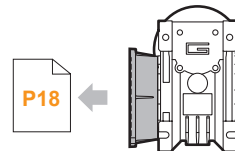
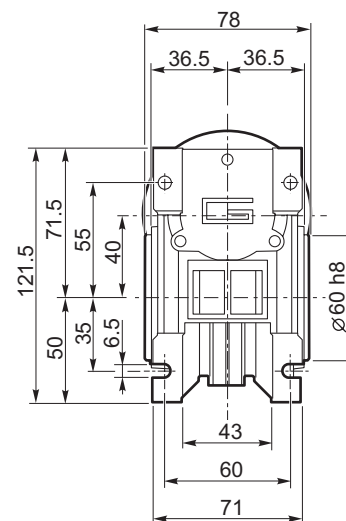
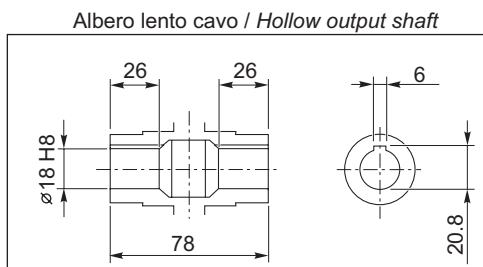

ECMP250/063/040 F
ECMP250/063/040 FL
ECMP250/063/040 FB

Motori / Motors IP66

P18

ECMP250/063/050 U

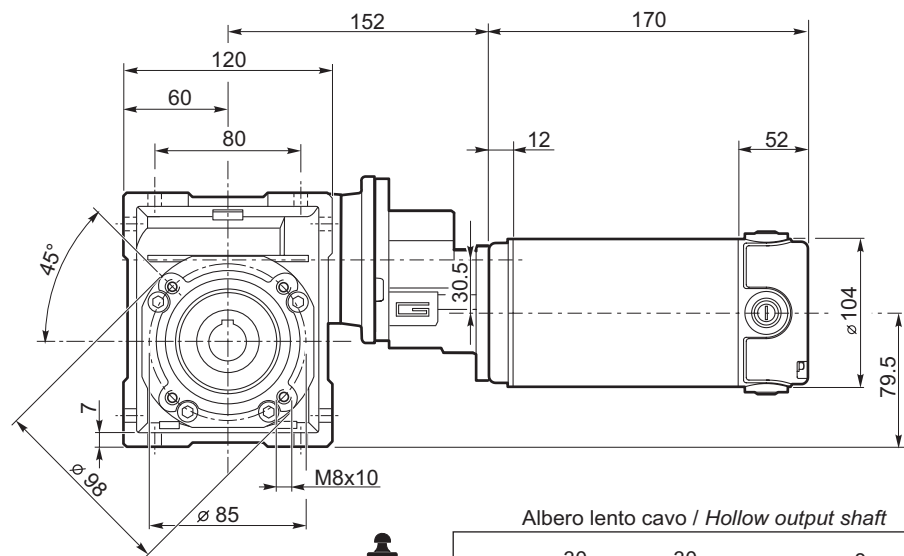

Kg
8.7

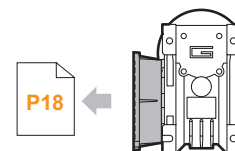
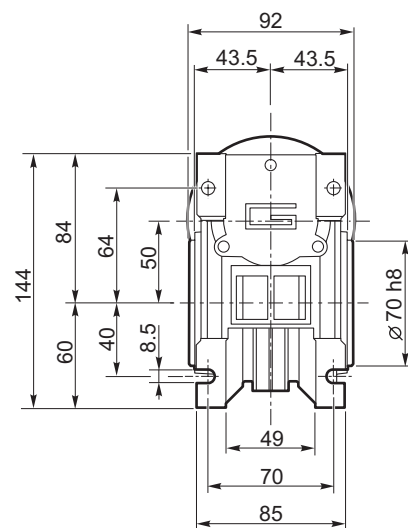
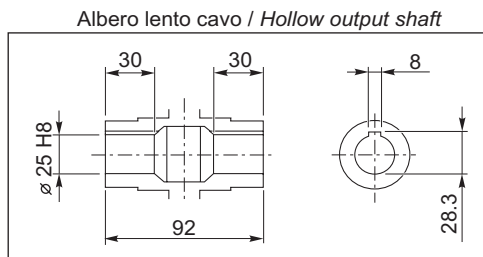

ECMP250/063/050 F
ECMP250/063/050 FL
ECMP250/063/050 FB

Motori / Motors IP66

P18

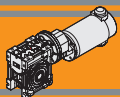

ECMP

Motoriduttori CC a vite senza fine con precoppia DC Pre stage wormgearmotors

Dimensioni

Dimensions

ECMP250/063/063 U

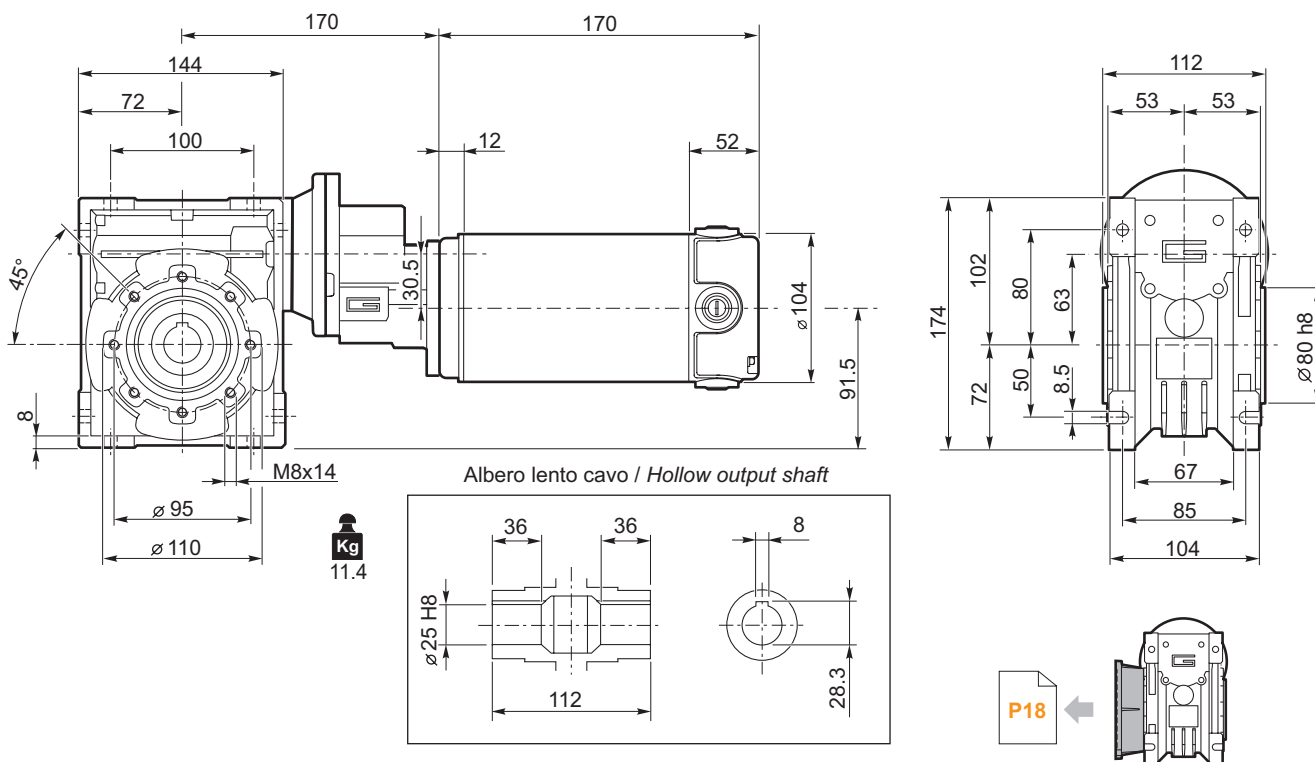

Motori / Motors IP66

➔ **I8**

P18

ECMP250/063/063 F
ECMP250/063/063 FL
ECMP250/063/063 FB

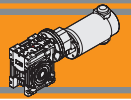

Dimensioni

Dimensions

ECMP350/063/050 U

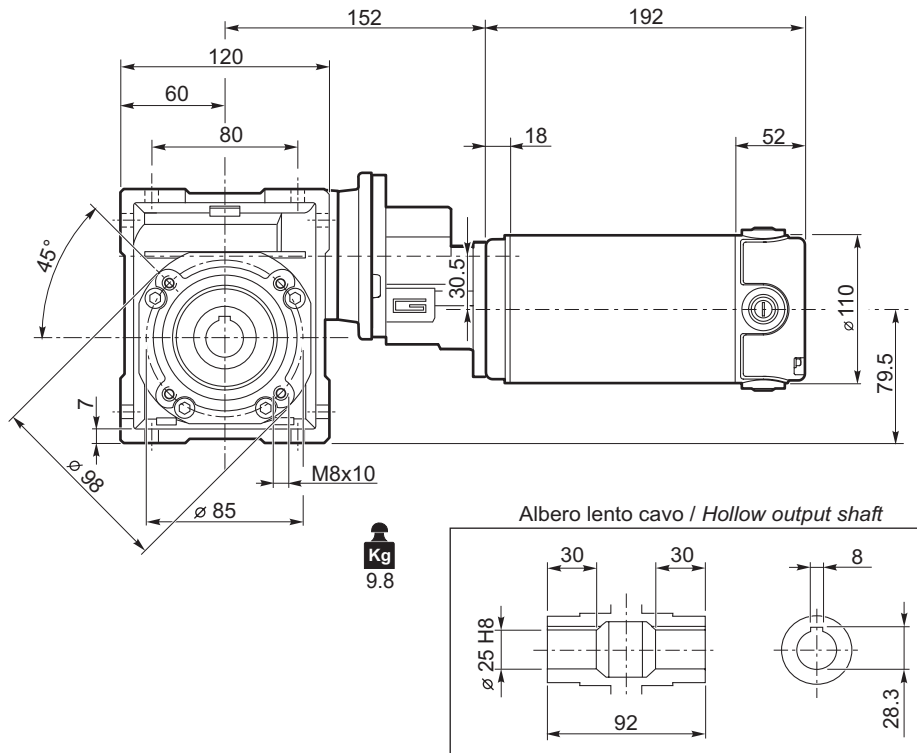

Kg
9.8

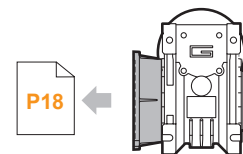
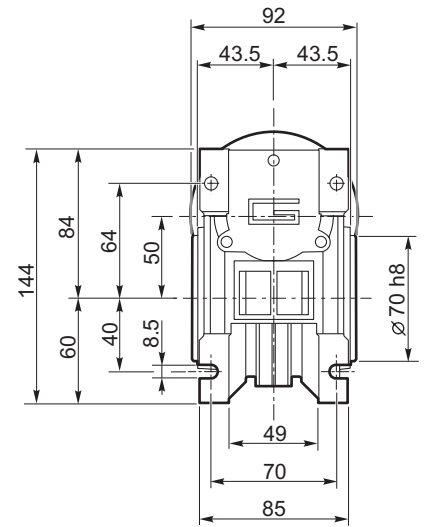

ECMP350/063/050 F
ECMP350/063/050 FL
ECMP350/063/050 FB

Motori / Motors IP66

I10

Freno / Brake

H23

ECMP350/063/063 U

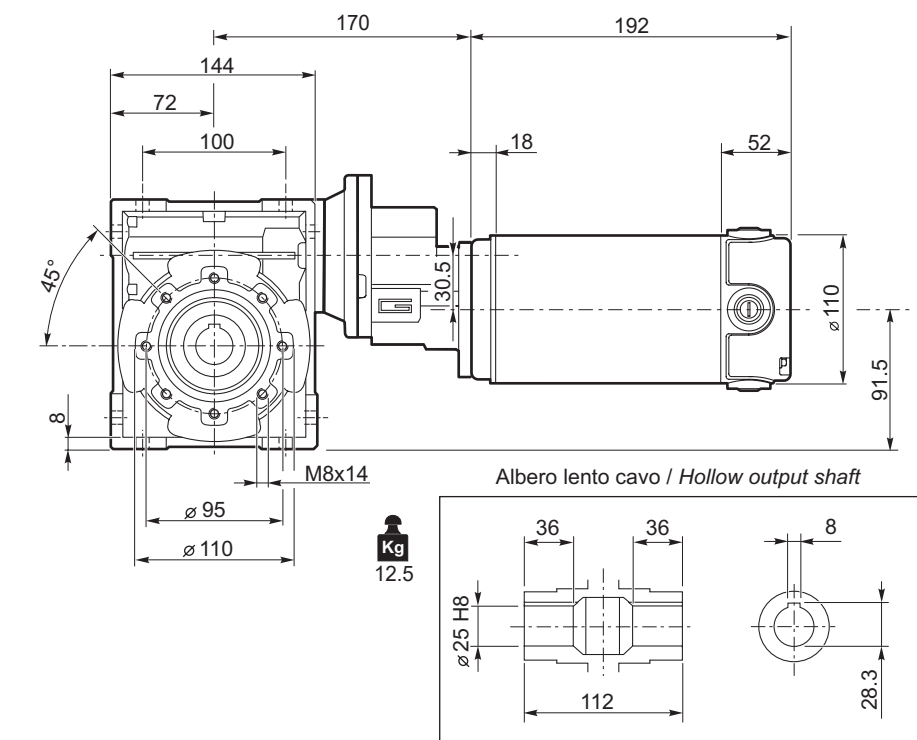

Kg
12.5

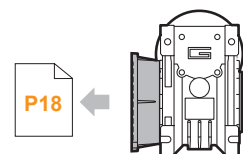
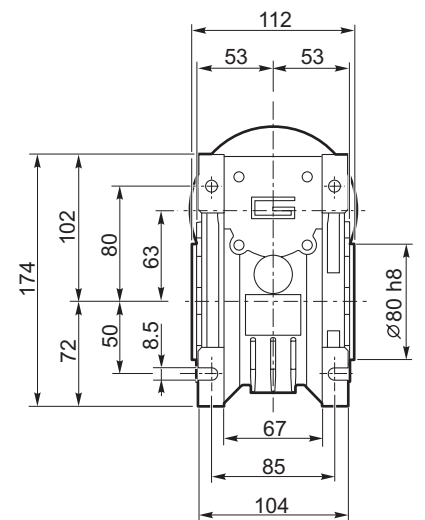

ECMP350/063/063 F
ECMP350/063/063 FL
ECMP350/063/063 FB

Motori / Motors IP66

I10

Freno / Brake

H23

ECMP

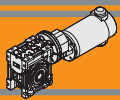

Dimensioni

Dimensions

ECMP350/071/063 U

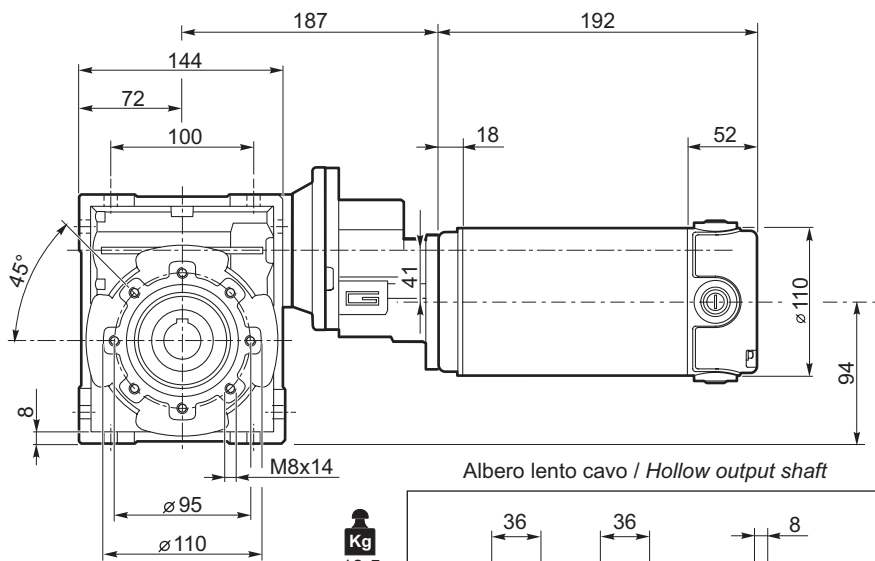

Kg
13.5

Albero lento cavo / Hollow output shaft

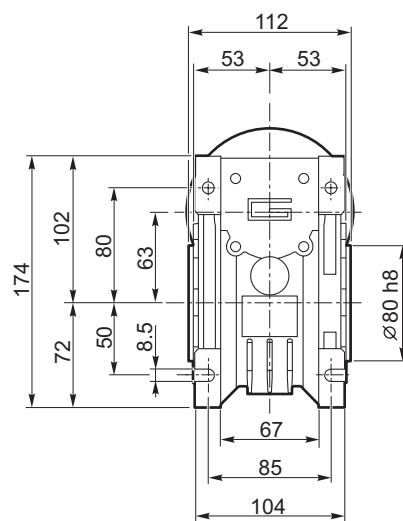
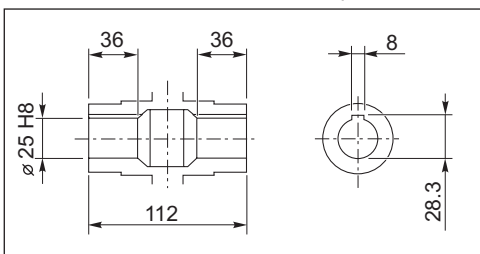

P18

ECMP350/071/063 F
ECMP350/071/063 FL
ECMP350/071/063 FB

Motori / Motors IP66

110

Freno / Brake

H23

ECMP350/071/070 U

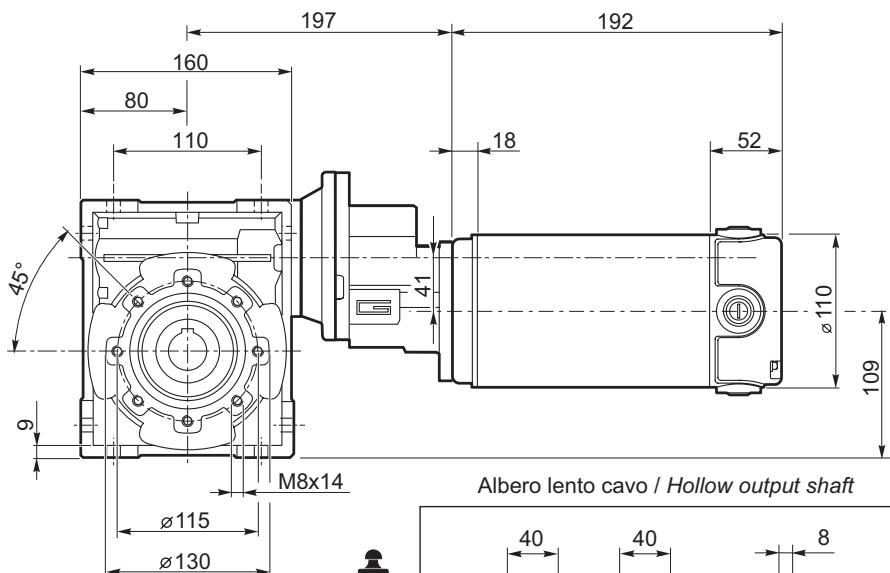

Kg
14.3

Albero lento cavo / Hollow output shaft

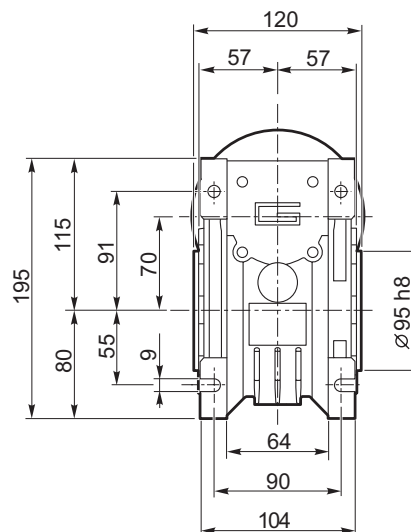
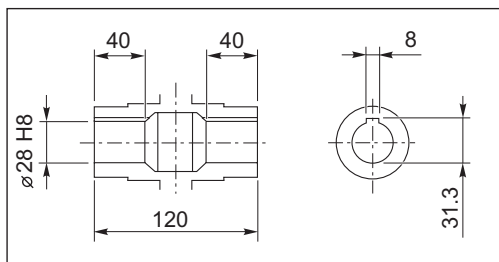

P18

ECMP350/071/070 F

Motori / Motors IP66

110

Freno / Brake

H23

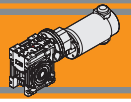

Dimensioni

Dimensions

ECMP350/071/075 U

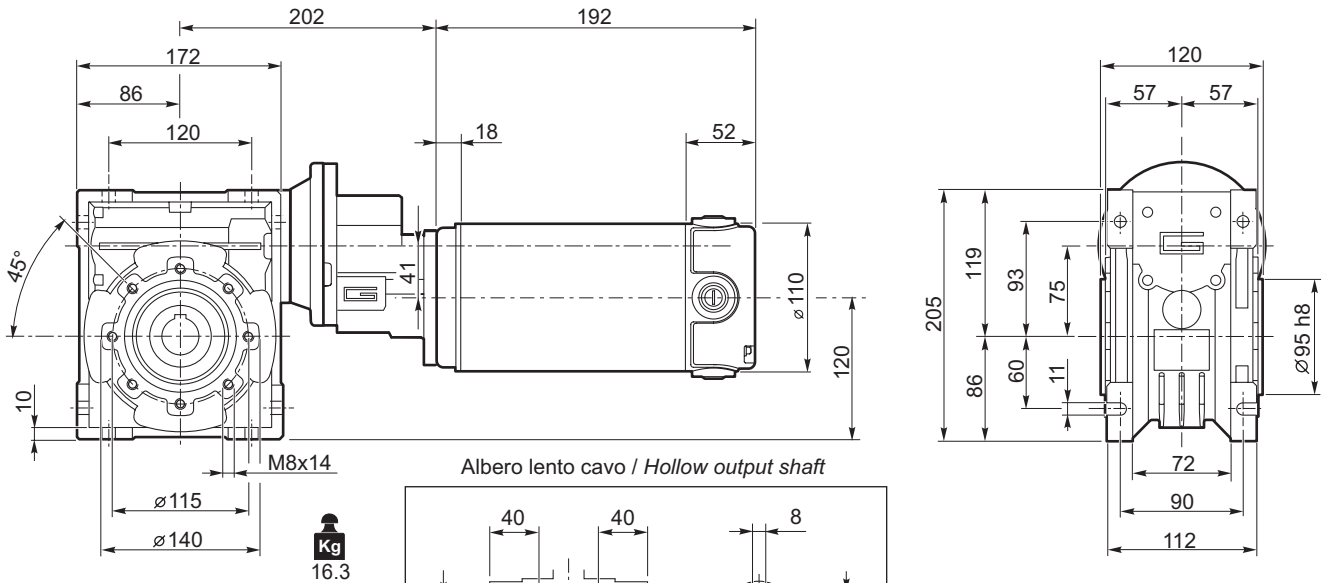

Albero lento cavo / Hollow output shaft

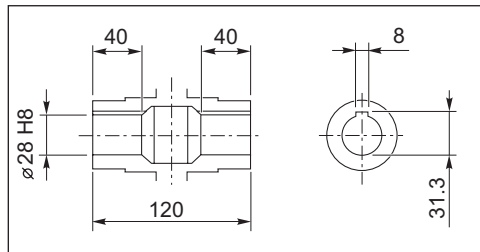

Kg
16.3

Motori / Motors IP66

➔ **I10**

Freno / Brake

➔ **H23**

P18

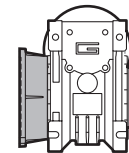

ECMP350/071/075 F

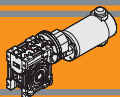

Dimensioni

Dimensions

ECMP600/071/050 U

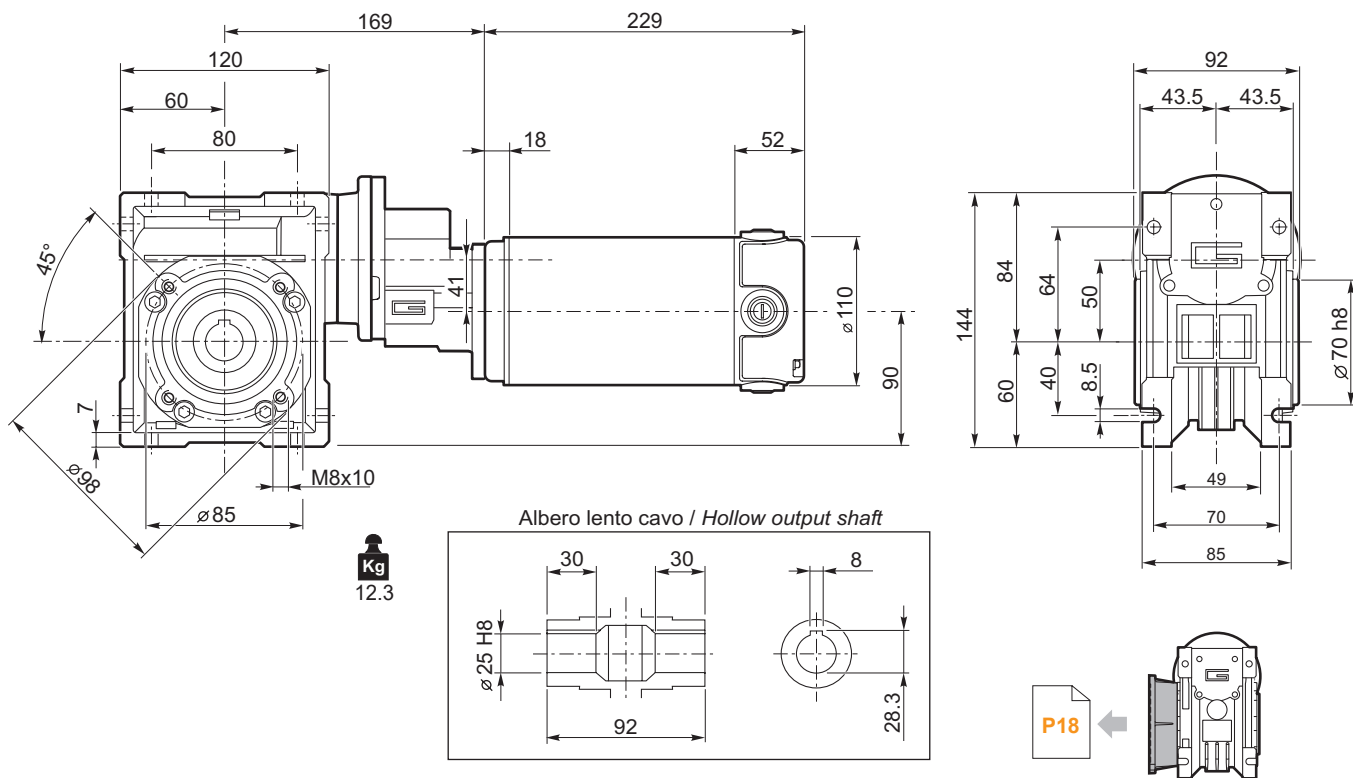

Motori / Motors IP66

I12

Freno / Brake

H23

ECMP600/071/050 F
ECMP600/071/050 FL
ECMP600/071/050 FB

ECMP600/071/063 U

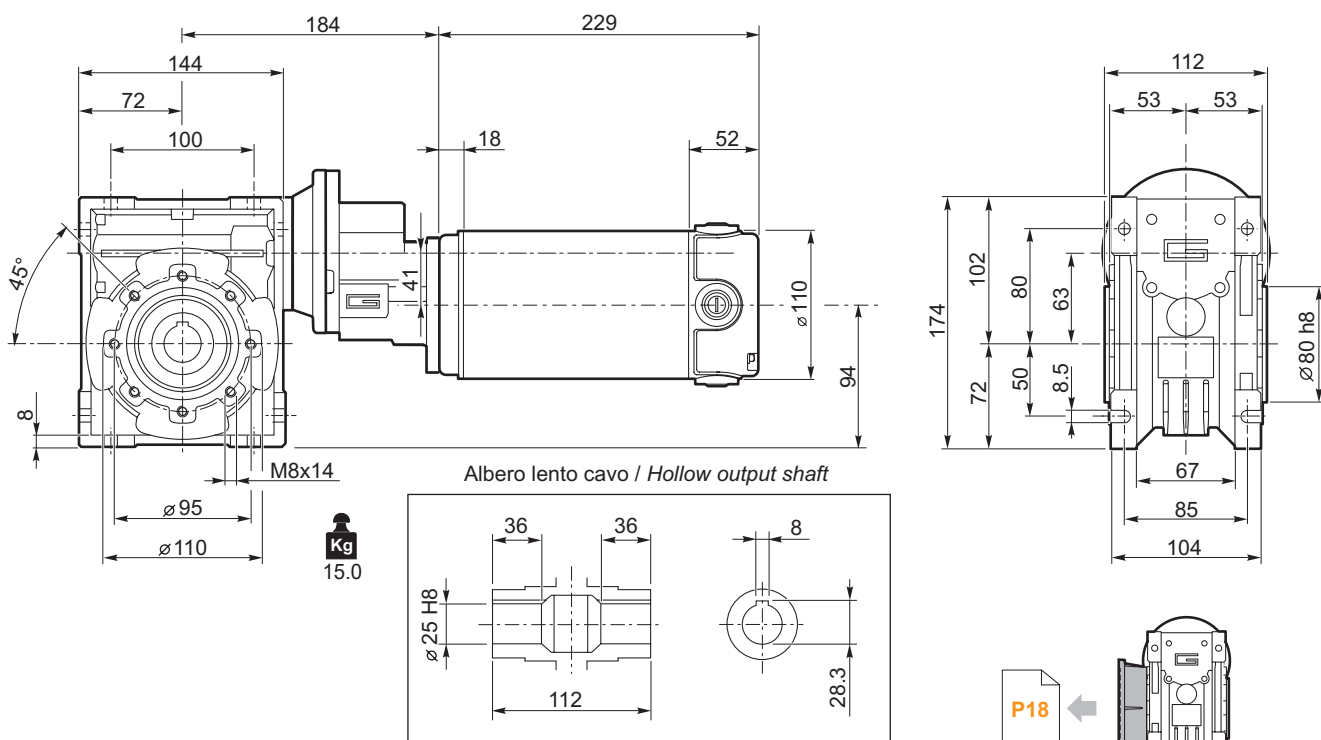

Motori / Motors IP66

I12

Freno / Brake

H23

ECMP600/071/063 F
ECMP600/071/063 FL
ECMP600/071/063 FB

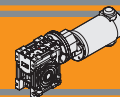

Dimensioni

Dimensions

ECMP600/071/070 U

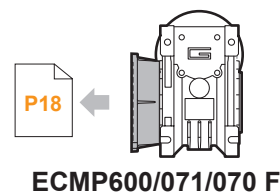
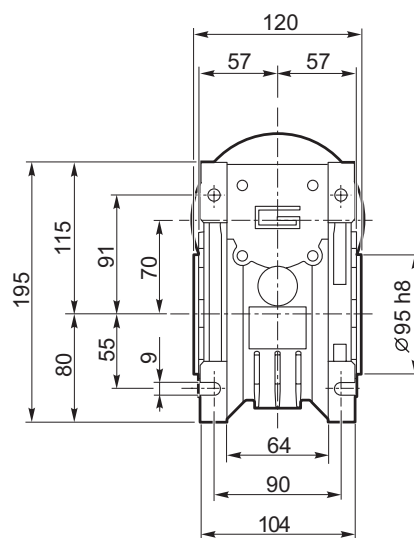
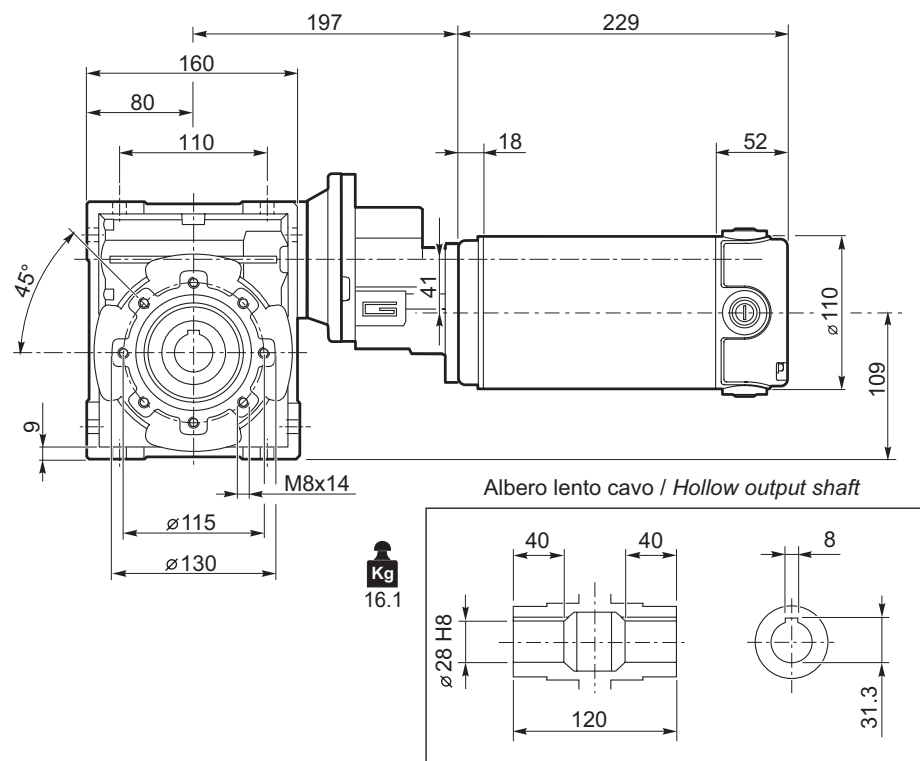

Motori / Motors IP66

➔ **I12**

Freno / Brake

➔ **H23**

ECMP600/071/075 U

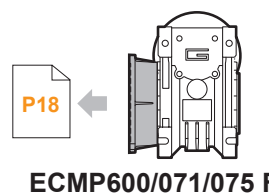
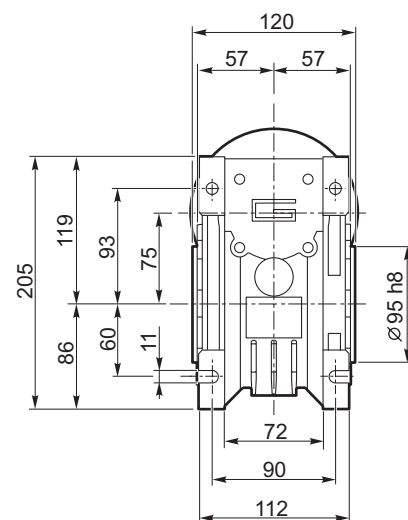
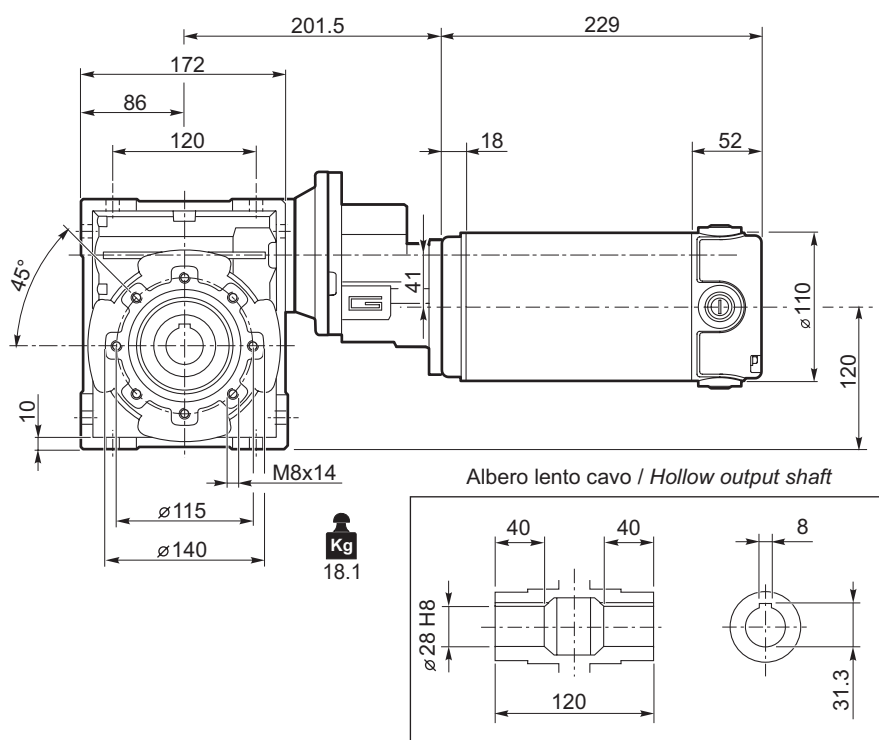

Motori / Motors IP66

➔ **I12**

Freno / Brake

➔ **H23**

ECMP

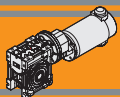

Dimensioni

Dimensions

EC100.24E
EC180.24E

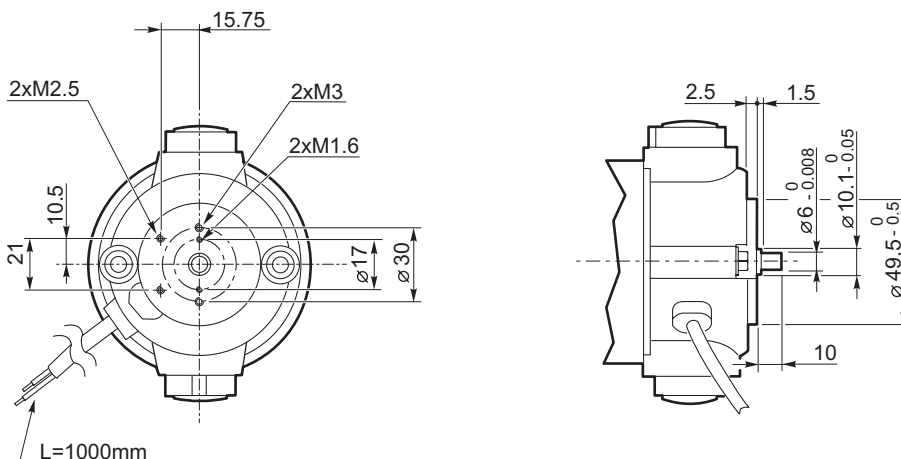

ECMP.../... F... Flange uscita / Output flanges

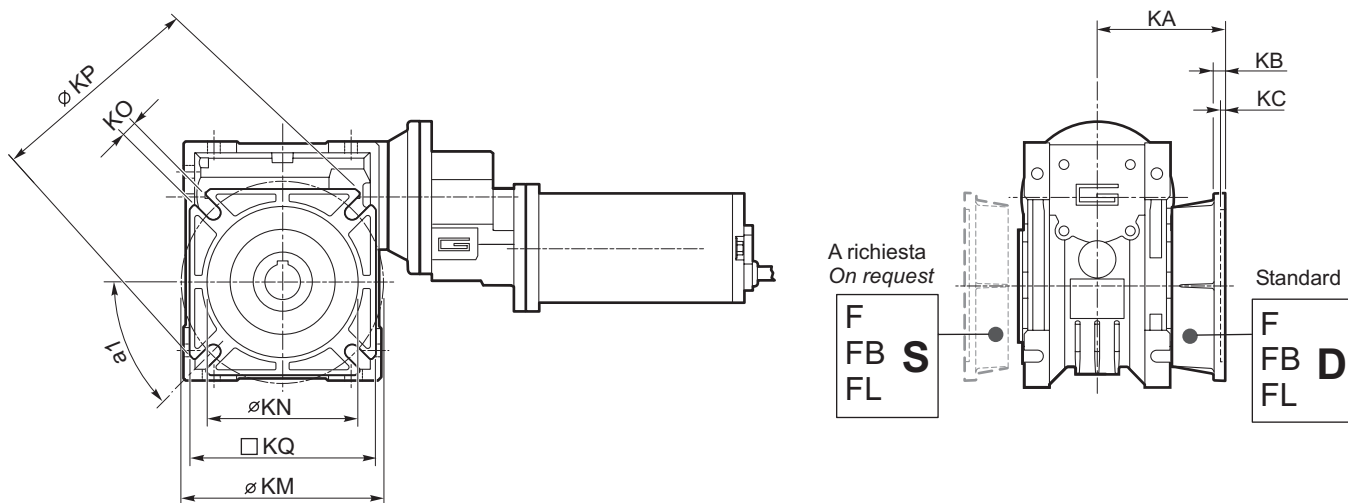

CMP	CMP..F								CMP..FB								CMP..FL								
	a1	KA	KB	KC	KM	KN _{H8}	KO	KP	KQ	KA	KB	KC	KM	KN _{H8}	KO	KP	KQ	KA	KB	KC	KM	KN _{H8}	KO	KP	KQ
056/030	45°	54.5	6	4	68	50	6.5(n.4)	80	70	—	—	—	—	—	—	—	—	—	—	—	—	—	—	—	—
056/040 063/040	45°	67	7.5	4	80-95	60	9(n.4)	110	95	80	8.5	5	115-125	95	9.5(n.4)	140	112	97	7.5	4.5	80-95	60	9(n.4)	110	95
063/050 071/050	45°	90	9	5	90-110	70	11(n.4)	125	110	89	9	5	130-145	110	9.5(n.4)	160	132	120	9	5	90-110	70	11(n.4)	125	110
063/063 071/063	45°	82	10	6	150-160	115	11(n.4)	180	142	98	10	5	165-180	130	11(n.4)	200	160	112	10	6	150-160	115	11(n.4)	180	142
071/070	45°	107	13	6	165-180	130	14(n.4)	200	170	—	—	—	—	—	—	—	—	—	—	—	—	—	—	—	—
071/075	45°	111	13	6	165-180	130	14(n.4)	200	170	—	—	—	—	—	—	—	—	—	—	—	—	—	—	—	—

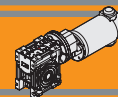

Opzioni

Options

VS - Vite sporgente / Extended input shaft

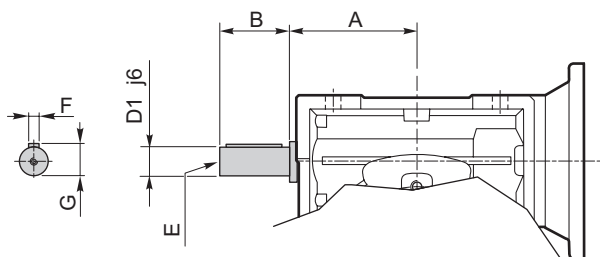

SC - Safety cover

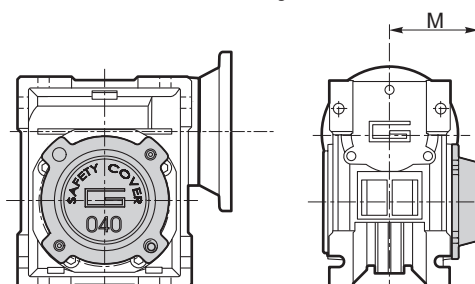

CMP	A	B	D ₁ j6	E	F	G
056/030	45	20	9	M4	3	10.2
056/040 063/040	53	23	11	M5	4	12.5
063/050	64	30	14	M6	5	16
063/063 071/063 080/063	75	40	19	M6	6	21.5
071/070	84	40	19	M6	6	21.5
071/075	90	50	24	M8	8	27

	M
CM 030	47
CM 040	54.5
CM 050	62.5
CM 063	73
CM 070	75
CM 075	79

Costruito su richiesta
Built on request

Accessori

Accessories

Albero lento semplice e doppio

CMP	d h7	B	B1	G1	L	L1	f	b1	t1
056/030	14	30	32.5	63	102	128	M6	5	16
056/040 063/040	18	40	43	78	128	164	M6	6	20.5
063/050	25	50	53.5	92	153	199	M10	8	28
063/063 071/063 080/063	25	50	53.5	112	173	219	M10	8	28
071/070	28	60	63.5	120	192	247	M10	8	31
071/075	28	60	63.5	120	192	247	M10	8	31

Single and double output shaft

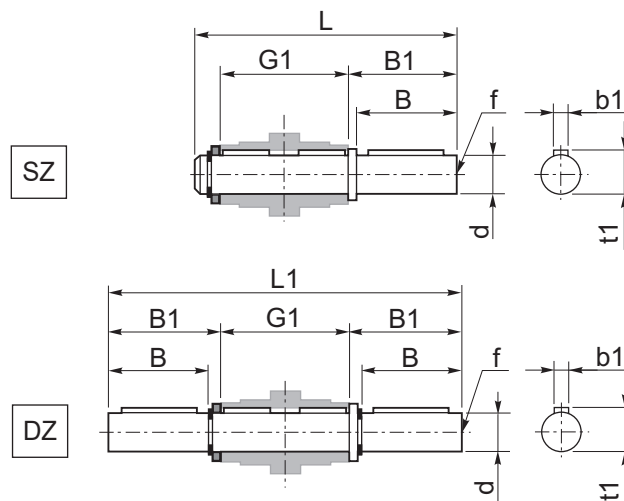

Braccio di reazione

CMP	K1	G	KG	KH	R
056/030	85	14	23	8	15
056/040 063/040	100	14	31	10	18
063/050	100	14	38	10	18
063/063 071/063 080/063	150	14	47.5	10	18
071/070	200	25	46.5	20	30
071/075	200	25	46.5	20	30

Torque arm

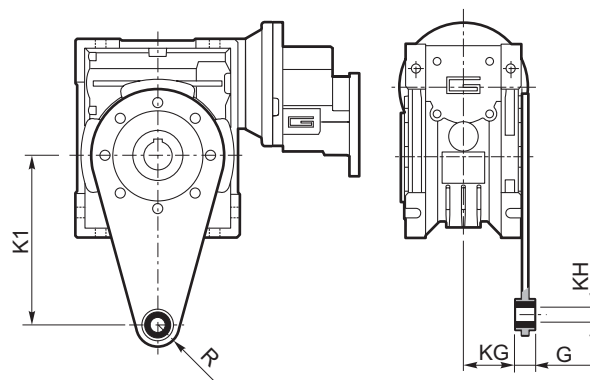



Motoriduttori CC a vite senza fine combinati
DC double reduction wormgearmotors





Indice	Index	Pag. Page
Caratteristiche tecniche	<i>Technical features</i>	Q2
Designazione	<i>Classification</i>	Q2
Simbologia	<i>Symbols</i>	Q2
Esecuzioni di montaggio	<i>Mounting executions</i>	Q2
Combinazioni rapporti	<i>Combination ratio</i>	Q3
Lubrificazione	<i>Lubrication</i>	Q3
Dati tecnici per servizio S2	<i>Technical data for S2 duty</i>	Q4
Motori applicabili	<i>Motor adapters</i>	Q9
Dimensioni	<i>Dimensions</i>	Q10
Accessori	<i>Accessories</i>	Q24
Opzioni	<i>Options</i>	Q24

Questa sezione annulla e sostituisce ogni precedente edizione o revisione. Qualora questa sezione non Vi sia giunta in distribuzione controllata, l'aggiornamento dei dati ivi contenuto non è assicurato. **In tal caso la versione più aggiornata è disponibile sul nostro sito internet www.transtecno.com**

This section replaces any previous edition and revision. If you obtained this catalogue other than through controlled distribution channels, the most up to date content is not guaranteed. In this case the latest version is available on our web site www.transtecno.com

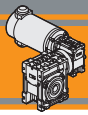

Caratteristiche tecniche

Technical features

Le caratteristiche principali dei motoriduttori CC a vite senza fine combinati a magneti permanenti in ferrite serie ECMM sono:

The main features of ECMM ferrite permanent magnets DC reduction wormgearmotors range are:

- Alimentazione in bassa tensione 12/24Vcc
- Possibilità di montaggio encoder
- Potenze motore disponibili da 100 a 800W S2
- Magneti in ferrite
- Carcassa in pressofusione di alluminio nelle grandezze 026, 030, 040, 050, 063, 075, 090 e 110. La grandezza 130 è costruita con carcassa in ghisa
- Lubrificazione permanente con olio sintetico
- Low voltage power supply 12/24Vdc
- Suitable for encoder assembly
- Motor power ratings available from 100 up to 800W S2
- Ferrite magnets
- Die cast aluminium housing on sizes 026, 030, 040, 050, 063, 075, 090 and 110. Cast iron housing on size 130
- Permanent synthetic oil long life lubrication

Designazione

Classification

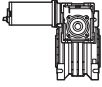
MOTORIDUTTORE / GEARMOTOR													
ECMM	100/026/026				U	150	SZDX	BRSX	90	B3	UB1	120	VS1
Tipo Type	Grandezza Size				Versione Version	Rapporto Ratio	Albero di uscita Output shaft	Braccio di reazione Torque arm	Angolo Angle	Pos. di montaggio Mounting position	Esecuzione di montaggio Mounting execution	Versione motore Motor version	Opzioni Options
	070/026/026	100/026/026	180/026/040	350/030/040	U F...	vedi tabelle see tables	SZDX SZSX DZ	BRDX BRSX *	0° 90° 180° 270°	B3 B8 B6 B7 V5 V6	UB1 UB2 US1 US2 UV1 UV2 UC1 UC2	120 240 24E	VS1 VS2
	070/026/026 (D11)	100/026/026 (D11)	180/026/050	350/030/050									
	070/026/026 (D14)	100/026/026 (D14)	180/030/040	350/030/063									
	070/026/030	100/026/030	180/030/050	350/040/070									
	070/026/040	100/026/040	180/030/063	350/040/075									
	070/026/050	100/026/050	180/040/070	350/040/090									
	070/030/040	100/030/040	180/040/075	350/050/110									
	070/030/050	100/030/050	180/040/090	350/063/130									
	070/030/063	100/030/063	180/050/110										
	070/040/070	100/040/075	250/030/040	600/040/070									
	070/040/075	100/040/090	250/030/050	600/040/075									
	070/040/090		250/030/063	600/040/090									
			250/040/070	600/050/110									
			250/040/075	600/063/130									
			250/040/090										
			250/050/110										

* NOTA: il braccio di reazione viene fornito smontato.
NOTE: the torque arm will be supplied not assembled.

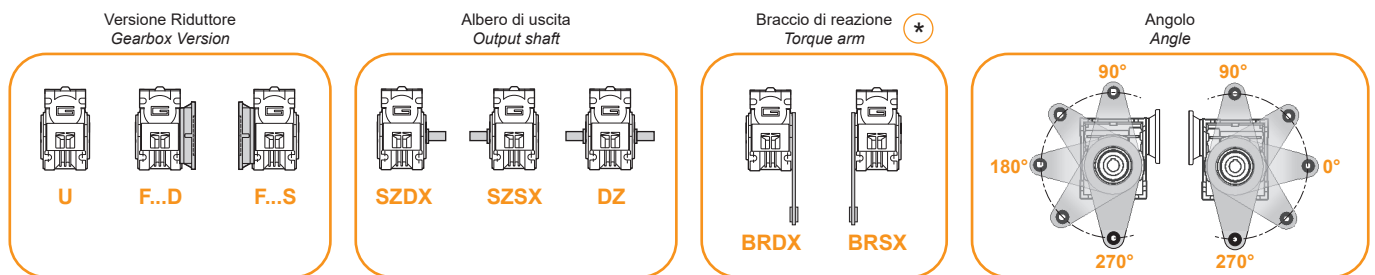

Simbologia

Symbols

n_1 [min ⁻¹]	Velocità in ingresso / Input speed	M_2 [Nm]	Coppia in uscita in funzione di P_1 / Output torque referred to P_1
n_2 [min ⁻¹]	Velocità in uscita / Output speed	sf	Fattore di servizio / Service factor
i	Rapporto di riduzione / Ratio	R_2 [N]	Carico radiale ammissibile in uscita / Permitted output radial load
P_1 [kW]	Potenza in entrata / Input power	A_2 [N]	Carico assiale ammissibile in uscita / Permitted output axial load



Esecuzioni di montaggio

Mounting executions

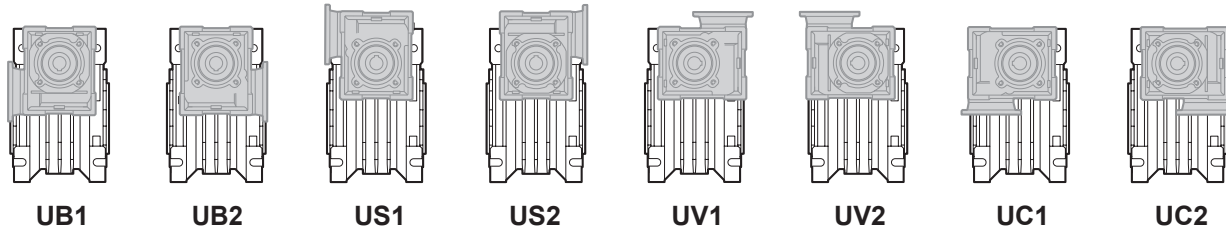

Combinazioni rapporti

Combination ratio

CMM 026/026 - CMM 026/030 - CMM 026/040 - CMM 026/050												
i (i ₁ x i ₂)												
	150	225	300	450	600	900	1200	1500	1800	2400	3000	3600
i ₁	10	15	10	15	20	30	40	50	60	60	60	60
i ₂	15	15	30	30	30	30	30	30	30	40	50	60

CMM 030/040 - CMM 030/050 - CMM 030/063 - CMM 040/070 - CMM 040/075 - CMM 040/090 - CMM 050/110 - CMM 063/130																
i (i ₁ x i ₂)																
	75	100	150	200	250	300	400	500	600	750	900	1200	1500	1800	2400	3000
i ₁	7.5	10	10	10	10	10	10	10	20	25	30	40	50	60	60	60
i ₂	10	10	15	20	25	30	40	50	30	30	30	30	30	30	40	50

Lubrificazione

Lubrication

Tutti i motoriduttori nelle taglie 26, 30, 40, 50, 63, 70, 75, 90, 110 sono forniti completi di lubrificante sintetico viscosità 320, pertanto possono essere installati in qualunque posizione di montaggio e non necessitano di manutenzione. Per la taglia 130 la lubrificazione dipende dalla posizione di montaggio

Permanent synthetic oil long-life lubrication (viscosity grade 320) makes it possible to use the gearmotors size 26, 30, 40, 50, 63, 70, 75, 90, 110 in all mounting positions; for this reason they can be installed in any assembly position and do not require maintenance. Only for size 130, the lubrication depended of mounting positions

Quantità di olio (litri) / Oil quantity (litres)						
	M1 (B3)	M3 (B8)	M6 (B6)	M5 (B7)	M4 (V5)	M2 (V6)
CM130	4.5	3.3	3.5	3.5	4.5	3.3

Lubrificato a vita
Life lubrication

Posizioni di montaggio / Mounting positions

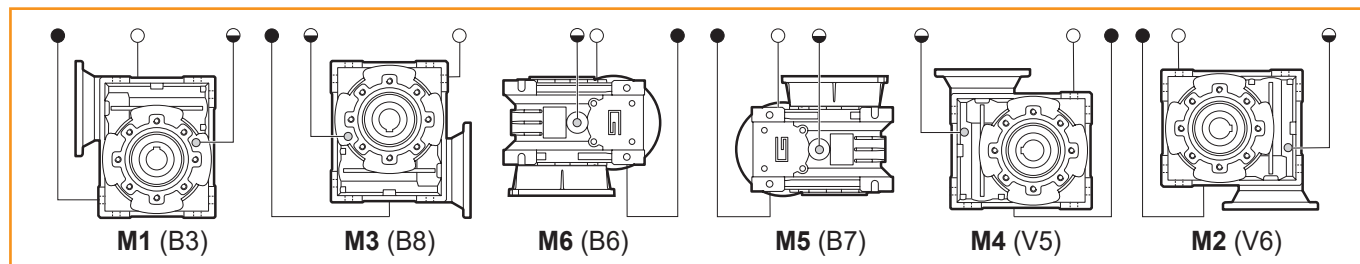



(standard)

- Sfiato e tappo di riempimento / Breather and filling plug
- ◐ Livello olio / Oil level plug
- Tappo di scarico / Oil drain plug



Dati tecnici per servizio S2

Technical data for S2 duty

P_1 [W]	n_2 [min ⁻¹]	M_2 [Nm]	sf	i		Versione motore Motor version	P_1 [W]	n_2 [min ⁻¹]	M_2 [Nm]	sf	i		Versione motore Motor version					
100							100											
(3000 min ⁻¹)	20.0	26	1.0	150	ECMM 070/026/026	12E/24E	(3000 min ⁻¹)	40.0	15	5.5	75	ECMM 070/030/040	12E/24E					
	13.3	26	1.0	225					30.0	20	4.2			100				
	10.0	27	1.0	300					20.0	28	3.2			150				
	6.7	27	1.0	450					15.0	36	2.1			200				
	5.0	27	1.0	600					12.0	43	1.6			250				
	3.3	27	1.0	900					10.0	46	2.0			300				
	2.5	27	1.0	1200					7.5	55	1.3			400				
	2.0	27	1.0	1500					6.0	63	1.1			500				
	1.7	27	1.0	1800					5.0	86	1.0			600				
	1.3	22	1.0	2400					4.0	103	0.9			750				
	1.0	20	1.0	3000					3.3	118	0.8			900				
	0.8	18	1.0	3600					2.5	74	1.0			1200				
									2.0	90	1.0			1500				
	20.0	26	1.5	150			ECMM 070/026/030	12E/24E		1.7	90			1.0	1800			
	13.3	39	1.0	225							1.3			74	1.0	2400		
	10.0	40	1.0	300					1.0	68	1.0	3000						
	6.7	40	1.0	450														
	5.0	40	1.0	600					15.0	36	3.8	200	ECMM 070/030/050	12E/24E				
	3.3	40	1.0	900					12.0	43	2.9	250						
	2.5	40	1.0	1200					10.0	46	3.5	300						
	2.0	40	1.0	1500					7.5	57	2.4	400						
	1.7	40	1.0	1800					6.0	64	2.0	500						
	1.3	34	1.0	2400					5.0	87	1.9	600						
	1.0	30	1.0	3000					4.0	105	1.5	750						
	0.8	27	1.0	3600					3.3	120	1.4	900						
									2.5	146	0.9	1200						
	20.0	27	3.2	150	ECMM 070/026/040	12E/24E				2.0	175	0.9			1500			
	13.3	40	2.2	225							1.7	201			0.8	1800		
	10.0	45	2.0	300					1.3	135	1.0	2400						
	6.7	66	1.4	450					1.0	125	1.0	3000						
	5.0	85	1.1	600														
	3.3	90	1.0	900					4.0	109	2.8	750			ECMM 070/030/063	12E/24E		
	2.5	90	1.0	1200					3.3	124	2.5	900						
	2.0	90	1.0	1500					2.5	149	1.7	1200						
	1.7	90	1.0	1800					2.0	181	1.7	1500						
	1.3	74	1.0	2400					1.7	208	1.5	1800						
	1.0	68	1.0	3000					1.3	249	1.0	2400						
	0.8	62	1.0	3600					1.0	288	0.8	3000						
	20.0	28	5.7	150			ECMM 070/026/050	12E/24E		2.5	155	2.5	1200	ECMM 070/040/070			12E/24E	
	13.3	42	3.9	225							2.0	193	2.4					1500
	10.0	46	3.5	300					1.7	221	2.1	1800						
	6.7	67	2.4	450					1.3	265	1.4	2400						
	5.0	86	1.9	600					1.0	307	1.1	3000						
	3.3	118	1.4	900														
	2.5	147	1.1	1200					2.5	158	3.0	1200	ECMM 070/040/075					12E/24E
	2.0	162	1.0	1500					2.0	193	2.8	1500						
	1.7	162	1.0	1800					1.7	221	2.5	1800						
	1.3	135	1.0	2400					1.3	270	1.7	2400						
	1.0	125	1.0	3000					1.0	307	1.3	3000						
	0.8	113	1.0	3600														
									1.3	285	2.9	2400			ECMM 070/040/090	12E/24E		
									1.0	331	2.1	3000						



N.B.
Verificare sempre che la coppia M2 utilizzata non ecceda il valore indicato nelle caselle in grigio
N.B.
Please check that the output torque M2 does not exceed the value in the grey areas

NOTA: per servizio continuo o altamente intermittente, contattare il servizio tecnico
NOTE: for continuous or highly intermittent duty, please contact our technical service



Dati tecnici per servizio S2

Technical data for S2 duty



P_1 [W]	n_2 [min ⁻¹]	M_2 [Nm]	sf	i		Versione motore Motor version	P_1 [W]	n_2 [min ⁻¹]	M_2 [Nm]	sf	i		Versione motore Motor version						
140							140												
(3000 min ⁻¹)	20.0	26	1.0	150	ECMM 100/026/026	120/240/24E	(3000 min ⁻¹)	40.0	21	3.9	75	ECMM 100/030/040	120/240/24E						
	13.3	26	1.0	225						30.0	28			3.0	100				
	10.0	27	1.0	300						20.0	38			2.3	150				
	6.7	27	1.0	450						15.0	50			1.5	200				
	5.0	27	1.0	600						12.0	59			1.1	250				
	3.3	27	1.0	900						10.0	63			1.4	300				
	2.5	27	1.0	1200						7.5	77			1.0	400				
	2.0	27	1.0	1500						6.0	87			0.8	500				
	1.7	27	1.0	1800						5.0	119			0.8	600				
	1.3	22	1.0	2400						4.0	90			1.0	750				
	1.0	20	1.0	3000						3.3	90			1.0	900				
	0.8	18	1.0	3600						2.5	74			1.0	1200				
										2.0	90			1.0	1500				
										1.7	90			1.0	1800				
										1.3	74			1.0	2400				
								1.0	68	1.0	3000								
	20.0	37	1.1	150	ECMM 100/026/030	120/240/24E						ECMM 100/030/050	120/240/24E						
	13.3	39	1.0	225						15.0	50			2.7	200				
	10.0	40	1.0	300						12.0	59			2.1	250				
	6.7	40	1.0	450						10.0	64			2.5	300				
	5.0	40	1.0	600						7.5	78			1.7	400				
	3.3	40	1.0	900						6.0	89			1.4	500				
	2.5	40	1.0	1200						5.0	121			1.3	600				
	2.0	40	1.0	1500						4.0	146			1.1	750				
	1.7	40	1.0	1800						3.3	166			1.0	900				
	1.3	34	1.0	2400						2.5	202			0.7	1200				
	1.0	30	1.0	3000						2.0	243			0.7	1500				
	0.8	27	1.0	3600						1.7	162			1.0	1800				
										1.3	135			1.0	2400				
										1.0	125			1.0	3000				
	20.0	38	2.3	150			ECMM 100/026/040	120/240/24E								ECMM 100/030/063	120/240/24E		
	13.3	55	1.6	225						6.0	92	2.5	500						
	10.0	63	1.4	300						5.0	125	2.5	600						
	6.7	92	1.0	450						4.0	151	2.1	750						
	5.0	90	1.0	600						3.3	172	1.8	900						
	3.3	90	1.0	900						2.5	206	1.3	1200						
	2.5	90	1.0	1200						2.0	252	1.2	1500						
	2.0	90	1.0	1500						1.7	288	1.1	1800						
	1.7	90	1.0	1800						1.3	346	0.8	2400						
	1.3	74	1.0	2400						1.0	232	1.0	3000						
	1.0	68	1.0	3000										ECMM 100/040/070	120/240/24E				
	0.8	62	1.0	3600						3.3	179	2.5	900						
										2.5	215	1.8	1200						
										2.0	267	1.7	1500						
										1.7	307	1.5	1800						
								1.3	368	1.0	2400								
								1.0	426	0.8	3000								
												ECMM 100/040/075	120/240/24E						
								3.3	179	3.1	900								
								2.5	219	2.2	1200								
								2.0	267	2.0	1500								
								1.7	307	1.8	1800								
								1.3	375	1.3	2400								
								1.0	426	0.9	3000								
																ECMM 100/040/090	120/240/24E		
								1.7	322	2.9	1800								
								1.3	395	2.1	2400								
								1.0	460	1.5	3000								

N.B.
Verificare sempre che la coppia M2 utilizzata non ecceda il valore indicato nelle caselle in grigio
N.B.
Please check that the output torque M2 does not exceed the value in the grey areas

NOTA: per servizio continuo o altamente intermittente, contattare il servizio tecnico

NOTE: for continuous or highly intermittent duty, please contact our technical service

**Dati tecnici per servizio S2****Technical data for S2 duty**

P_1 [W]	n_2 [min ⁻¹]	M_2 [Nm]	sf	i		Versione motore Motor version	P_1 [W]	n_2 [min ⁻¹]	M_2 [Nm]	sf	i		Versione motore Motor version		
250							250								
(3000 min ⁻¹)	20.0	70	1.2	150	ECMM 180/026/040	120/240	(3000 min ⁻¹)	12.0	113	3.6	250	ECMM 180/040/075	120/240/24E		
	13.3	103	0.8	225				10.0	125	4.4	300				
	10.0	116	0.8	300				7.5	153	3.1	400				
	20.0	73	2.2	150	ECMM 180/026/050	120/240		6.0	174	2.3	500				
	13.3	108	1.5	225				5.0	239	2.3	600				
	10.0	118	1.4	300				4.0	288	1.9	750				
	6.7	173	0.9	450				3.3	333	1.6	900				
	5.0	223	0.7	600				2.5	407	1.2	1200				
	40.0	40	2.1	75			ECMM 180/030/040	120/240/24E		2.0	497	1.1	1500		
	30.0	52	1.6	100						1.7	570	1.0	1800		
	20.0	71	1.2	150		1.3			470	1.0	2400				
	15.0	92	0.8	200		1.0			403	1.0	3000				
	12.0	67	1.0	250		5.0			251	3.8	600				
	10.0	90	1.0	300		4.0			302	3.1	750				
	7.5	74	1.0	400		3.3			349	2.7	900				
	6.0	68	1.0	500		2.5			429	1.9	1200				
	5.0	90	1.0	600		2.0			522	1.8	1500				
	4.0	90	1.0	750		1.7			599	1.6	1800				
	3.3	90	1.0	900		1.3	735	1.1	2400						
	40.0	40	3.9	75	ECMM 180/030/050	120/240/24E		1.0	855	0.8	3000				
	30.0	52	3.0	100				3.3	359	4.4	900				
	20.0	74	2.2	150				2.5	457	3.2	1200				
	15.0	94	1.5	200				2.0	545	2.9	1500				
	12.0	110	1.1	250				1.7	627	2.5	1800				
	10.0	120	1.4	300				1.3	796	1.8	2400				
	7.5	146	0.9	400				1.0	947	1.3	3000				
	6.0	165	0.8	500				3.3	359	4.4	900				
	5.0	226	0.7	600				2.5	457	3.2	1200				
	4.0	162	1.0	750				2.0	545	2.9	1500				
	3.3	162	1.0	900		1.7	627	2.5	1800						
	2.5	135	1.0	1200		1.3	796	1.8	2400						
	2.0	162	1.0	1500		1.0	947	1.3	3000						
	1.7	162	1.0	1800											
	15.0	92	2.8	200	ECMM 180/030/063	120/240/24E									
	12.0	108	2.1	250											
	10.0	124	2.5	300											
	7.5	149	1.7	400											
	6.0	172	1.3	500											
	5.0	233	1.3	600											
	4.0	281	1.1	750											
	3.3	320	1.0	900											
	2.5	384	0.7	1200											
	2.0	468	0.7	1500											
	1.7	310	1.0	1800											
	1.3	260	1.0	2400											
	1.0	232	1.0	3000											
	12.0	113	3.0	250	ECMM 180/040/070	120/240/24E									
	10.0	125	3.6	300											
	7.5	150	2.5	400											
	6.0	174	1.9	500											
	5.0	239	1.9	600											
	4.0	288	1.6	750											
	3.3	333	1.4	900											
	2.5	399	0.9	1200											
	2.00	497	0.9	1500											
	1.67	570	0.8	1800											
	1.25	379	1.0	2400											
	1.00	336	1.0	3000											
350							350								
(3000 min ⁻¹)	40.0	55	1.5	75	ECMM 250/030/040	120/240	(3000 min ⁻¹)	40.0	55	1.5	75	ECMM 250/030/050	120/240		
	30.0	72	1.2	100				30.0	73	2.1	100				
	20.0	100	0.9	150				20.0	104	1.5	150				
	15.0	74	1.0	200				15.0	131	1.0	200				
	12.0	67	1.0	250				12.0	154	0.8	250				
	10.0	90	1.0	300				10.0	168	1.0	300				
	7.5	74	1.0	400				7.5	204	0.7	400				
	6.0	68	1.0	500				6.0	125	1.0	500				
	5.0	90	1.0	600				5.0	162	1.0	600				
	4.0	90	1.0	750				4.0	162	1.0	750				
	3.3	90	1.0	900		3.3	162	1.0	900						
	2.5	74	1.0	1200		2.5	135	1.0	1200						
	2.0	90	1.0	1500		2.00	162	1.0	1500						

N.B.
Verificare sempre che la coppia M2 utilizzata non ecceda il valore indicato nelle caselle in grigio
N.B.
Please check that the output torque M2 does not exceed the value in the grey areas





NOTA: per servizio continuo o altamente intermittente, contattare il servizio tecnico





NOTE: for continuous or highly intermittent duty, please contact our technical service



Dati tecnici per servizio S2

Technical data for S2 duty

P_1 [W]	n_2 [min ⁻¹]	M_2 [Nm]	sf	i		Versione motore Motor version		
350								
(3000 min ⁻¹)	30.0	74	3.9	100		ECMM 250/030/063 120/240		
	20.0	103	3.0	150				
	15.0	129	2.0	200				
	12.0	152	1.5	250				
	10.0	173	1.8	300				
	7.5	208	1.2	400				
	6.0	241	1.0	500				
	5.0	327	0.9	600				
	4.0	393	0.8	750				
	3.3	448	0.7	900				
	2.5	260	1.0	1200				
	2.00	310	1.0	1500				
	15.0	133	2.9	200				ECMM 250/040/070 120/240
	12.0	158	2.2	250				
	10.0	175	2.6	300				
	7.5	210	1.8	400				
	6.0	244	1.4	500				
	5.0	335	1.4	600				
	4.0	403	1.1	750				
	3.3	466	1.0	900				
	2.5	379	1.0	1200				
	2.00	453	1.0	1500				
	1.67	453	1.0	1800				
	1.25	379	1.0	2400				
	1.00	336	1.0	3000				
	15.0	134	3.5	200		ECMM 250/040/075 120/240		
	12.0	158	2.6	250				
	10.0	175	3.1	300				
	7.5	214	2.2	400				
	6.0	244	1.7	500				
	5.0	335	1.6	600				
	4.0	403	1.4	750				
	3.3	466	1.2	900				
	2.5	569	0.8	1200				
	2.00	696	0.8	1500				
	1.67	547	1.0	1800				
	1.25	470	1.0	2400				
	1.00	403	1.0	3000				
	12.0	168	4.2	250				ECMM 250/040/090 120/240
	10.0	184	5.1	300				
	7.5	226	3.6	400				
	6.0	263	2.6	500				
	5.0	351	2.7	600				
	4.0	423	2.2	750				
	3.3	489	1.9	900				
	2.5	600	1.4	1200				
	2.00	730	1.3	1500				
	1.67	838	1.1	1800				
	1.25	1029	0.8	2400				
	1.00	689	1.0	3000				

P_1 [W]	n_2 [min ⁻¹]	M_2 [Nm]	sf	i		Versione motore Motor version		
350								
(3000 min ⁻¹)	6.0	286	4.5	500		ECMM 250/050/110 120/240		
	5.0	361	4.4	600				
	4.0	441	3.6	750				
	3.3	503	3.2	900				
	2.5	639	2.3	1200				
	2.00	763	2.1	1500				
	1.67	877	1.8	1800				
	1.25	1115	1.3	2400				
	1.00	1325	1.0	3000				
500								
(3000 min ⁻¹)	40.0	78	1.1	75		ECMM 350/030/040 120/240		
	30.0	101	0.8	100				
	20.0	87	1.0	150				
	15.0	74	1.0	200				
	12.0	67	1.0	250				
	10.0	90	1.0	300				
	7.5	74	1.0	400				
	40.0	79	2.0	75				ECMM 350/030/050 120/240
	30.0	103	1.5	100				
	20.0	146	1.1	150				
	15.0	184	0.7	200				
	12.0	216	0.6	250				
	10.0	235	0.7	300				
	7.5	135	1.0	400				
	6.0	125	1.0	500				
	5.0	162	1.0	600				
	4.0	162	1.0	750				
	3.3	162	1.0	900				
	40.0	80	3.6	75		ECMM 350/030/063 120/240		
	30.0	104	2.8	100				
	20.0	144	2.1	150				
	15.0	181	1.4	200				
	12.0	213	1.1	250				
	10.0	243	1.3	300				
	7.5	292	0.9	400				
	6.0	338	0.7	500				
	5.0	458	0.7	600				
	4.0	310	1.0	750				
	3.3	310	1.0	900				
	2.5	260	1.0	1200				
	2.0	310	1.0	1500				

N.B.
Verificare sempre che la coppia M2 utilizzata non ecceda il valore indicato nelle caselle in grigio
N.B.
Please check that the output torque M2 does not exceed the value in the grey areas



NOTA: per servizio continuo o altamente intermittente, contattare il servizio tecnico

NOTE: for continuous or highly intermittent duty, please contact our technical service



Dati tecnici per servizio S2

Technical data for S2 duty

P_1 [W]	n_2 [min ⁻¹]	M_2 [Nm]	sf	i		Versione motore Motor version	P_1 [W]	n_2 [min ⁻¹]	M_2 [Nm]	sf	i		Versione motore Motor version				
500							800										
(3000 min ⁻¹)	20.0	148	3.0	150	ECMM 350/040/070	120/240	(3000 min ⁻¹)	40.0	132	3.2	75	ECMM 600/040/070	120/240				
	15.0	186	2.1	200				30.0	172	2.4	100						
	12.0	222	1.5	250				20.0	239	1.8	150						
	10.0	246	1.8	300				15.0	301	1.3	200						
	7.5	295	1.3	400				12.0	359	0.9	250						
	6.0	341	1.0	500				10.0	398	1.1	300						
	5.0	469	1.0	600				7.5	477	0.8	400						
	4.0	565	0.8	750				6.0	336	1.0	500						
	3.3	653	0.7	900				5.0	453	1.0	600						
	2.5	379	1.0	1200				4.0	453	1.0	750						
	2.00	453	1.0	1500				3.3	453	1.0	900						
	1.67	453	1.0	1800				2.5	379	1.0	1200						
	1.25	379	1.0	2400													
	20.0	150	3.5	150			ECMM 350/040/075	120/240	40.0	132	3.8			75	ECMM 600/040/075	120/240	
	15.0	188	2.5	200						30.0	172			2.9			100
	12.0	222	1.8	250						20.0	242			2.2			150
	10.0	246	2.2	300						15.0	305			1.5			200
	7.5	300	1.6	400						12.0	359			1.1			250
	6.0	341	1.2	500						10.0	398			1.4			300
	5.0	469	1.2	600						7.5	486			1.0			400
	4.0	565	1.0	750		6.0			403	1.0	500						
	3.3	653	0.8	900		5.0			547	1.0	600						
	2.5	470	1.0	1200		4.0			547	1.0	750						
	2.0	547	1.0	1500		3.3			547	1.0	900						
	1.7	547	1.0	1800		2.5			470	1.0	1200						
	1.3	470	1.0	2400													
	12.0	236	3.0	250	ECMM 350/040/090	120/240	20.0	249	3.5	150	ECMM 600/040/090	120/240					
	10.0	258	3.7	300				15.0	318	2.5			200				
	7.5	317	2.6	400				12.0	381	1.9			250				
	6.0	369	1.9	500				10.0	418	2.3			300				
	5.0	493	1.9	600				7.5	513	1.6			400				
	4.0	593	1.6	750				6.0	597	1.2			500				
	3.3	685	1.4	900				5.0	797	1.2			600				
	2.5	841	1.0	1200				4.0	960	1.0			750				
	2.0	1024	0.9	1500				3.3	1109	0.9			900				
	1.7	1175	0.8	1800				2.5	813	1.0			1200				
	1.3	813	1.0	2400													
	1.0	689	1.0	3000													
	6.0	401	3.2	500	ECMM 350/050/110	120/240	12.0	402	3.2	250	ECMM 600/050/110	120/240					
	5.0	506	3.1	600				10.0	429	3.7			300				
	4.0	618	2.6	750				7.5	545	2.6			400				
	3.3	705	2.3	900				6.0	648	2.0			500				
	2.5	896	1.6	1200				5.0	819	1.9			600				
	2.0	1070	1.5	1500				4.0	1000	1.6			750				
	1.7	1230	1.3	1800				3.3	1141	1.4			900				
	1.3	1563	0.9	2400				2.5	1450	1.0			1200				
	1.0	1272	1.0	3000				2.0	1731	0.9			1500				
								1.7	1990	0.8			1800				
								1.3	1443	1.0			2400				
								1.0	1272	1.0			3000				
	4.0	645	2.6	750	ECMM 350/063/130	120/240	7.5	563	2.8	400	ECMM 600/063/130	120/240					
	3.3	737	2.3	900				6.0	682	2.2			500				
	2.5	938	1.7	1200				5.0	845	2.0			600				
	2.0	1135	1.5	1500				4.0	1044	1.6			750				
	1.7	1306	1.3	1800				3.3	1192	1.4			900				
	1.3	1662	1.0	2400				2.5	1517	1.1			1200				
	1.0	2011	0.7	3000				2.0	1836	0.9			1500				
								1.7	2112	0.8			1800				
								1.3	1600	1.0			2400				
								1.0	1500	1.0			3000				

N.B.
Verificare sempre che la coppia M_2 utilizzata non ecceda il valore indicato nelle caselle in grigio
N.B.
Please check that the output torque M_2 does not exceed the value in the grey areas

NOTA: per servizio continuo o altamente intermittente, contattare il servizio tecnico

NOTE: for continuous or highly intermittent duty, please contact our technical service



Motori applicabili

Motor adapters

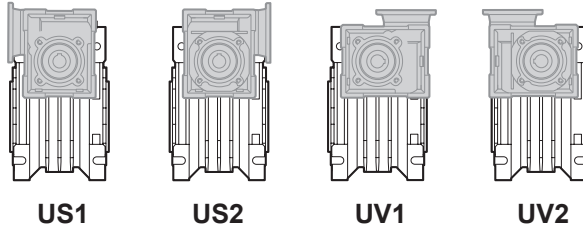

US1

US2

UV1

UV2

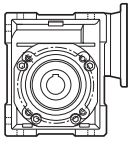
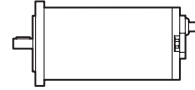

		EC			
		070.12E 070.24E	100.120 100.240	100.24E	180.120 180.240
CMM	026/026	150 - 3600	150 - 3600	150 - 3600	150 - 3600

150 - 3600

Rapporti di riduzione i
Ratio i

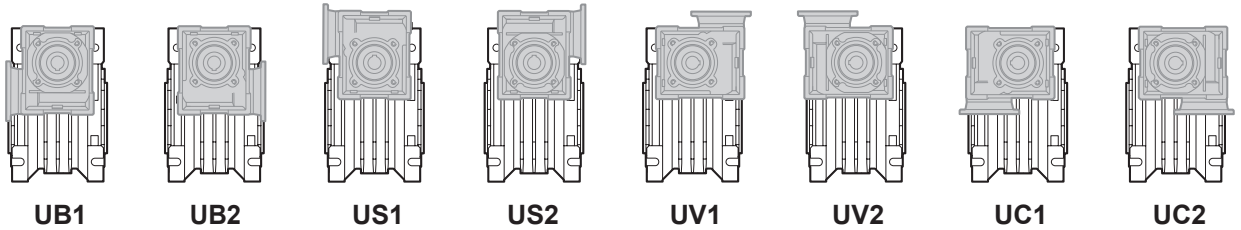

UB1

UB2

US1

US2

UV1

UV2

UC1

UC2

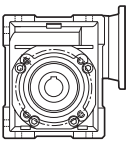
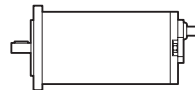

		EC							
		070.12E 070.24E	100.120 100.240	100.24E	180.120 180.240	180.24E	250.120 250.240	350.120 350.240	600.120 600.240
CMM	026/030	150 - 3600	150 - 3600	150 - 3600	150 - 3600				
	026/040	150 - 3600	150 - 3600	150 - 3600	150 - 3600				
	026/050	150 - 3600	150 - 3600	150 - 3600	150 - 3600				
	030/040	75 - 3000	75 - 3000	75 - 3000	75 - 3000	75 - 1500	75 - 1500	75 - 1500	
	030/050	75 - 3000	75 - 3000	75 - 3000	75 - 3000	75 - 1500	75 - 1500	75 - 1500	
	030/063	75 - 3000	75 - 3000	75 - 3000	75 - 3000	75 - 1500	100 - 1500	75 - 1500	
	040/070	75 - 3000	75 - 3000	75 - 3000	75 - 3000	75 - 3000	200 - 3000	75 - 3000	75 - 1200
	040/075	75 - 3000	75 - 3000	75 - 3000	75 - 3000	75 - 3000	200 - 3000	75 - 3000	75 - 1200
	040/090	75 - 3000	75 - 3000	75 - 3000	75 - 3000	75 - 3000	250 - 3000	75 - 3000	75 - 1200
	050/110				1200 - 3000	75 - 3000	500 - 3000	75 - 3000	75 - 3000
063/130							75 - 3000	75 - 3000	

150 - 3600

Rapporti di riduzione i
Ratio i

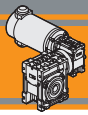

Dimensioni

Dimensions

CMM..U - CMM..F..																	
	A	C	D _{H8}	E	F	G	G1	H	H1	I	I1	K	L	M	N _{h8}	N1	N2
026/026 (D11)	45	70	11	83	22	47.5	50	35	34	26	26	34	42	55	45	22.5	21
026/026			12														
026/026 (D14)			14														
026/030	54	80	14	97	32	47.5	63	40	34	30	26	44	56	65	55	29	21
026/040	70	100	18	121.5	43	47.5	78	50	34	40	26	60	71	75	60	36.5	21
026/050	80	120	25	144	49	47.5	92	60	34	50	26	70	85	85	70	43.5	21
030/040	70	100	18	121.5	43	55	78	50	40	40	30	60	71	75	60	36.5	29
030/050	80	120	25	144	49	55	92	60	40	50	30	70	85	85	70	43.5	29
030/063	100	144	25	174	67	55	112	72	40	63	30	85	104	95	80	53	29
040/070	110	160	28	195	64	70	120	80	50	70	40	90	104	115	95	57	35.5
040/075	120	172	28	205	72	70	120	86	50	75	40	90	112	115	95	57	36.5
040/090	140	208	35	238	74	70	140	103	50	90	40	100	130	130	110	67	36.5

CMM..U - CMM..F..														
	O	P	Q	R	R1	S	T	V	Z	KE	a	b	t	Kg (*)
026/026 (D11)	6	—	37	49	49	5	15	21	76	7	—	4	12.8	3.3
026/026												4	13.8	
026/026 (D14)												5	16.2	
026/030	6.5	75	44	57	49	5.5	22	27	81	M6x10(n.4)	90°	5	16.3	4.1
026/040	6.5	87	55	71.5	49	6.5	26	35	91.5	M6x8(n.4)	45°	6	20.8	5.2
026/050	8.5	98	64	84	49	7	30	40	100.5	M8x10(n.4)	45°	8	28.3	6.7
030/040	6.5	87	55	71.5	57	6.5	26	35	122	M6x8(n.4)	45°	6	20.8	5.6
030/050	8.5	98	64	84	57	7	30	40	132	M8x10(n.4)	45°	8	28.3	6.7
030/063	8.5	110	80	102	57	8	36	50	145	M8x14(n.8)	45°	8	28.3	8.7
040/070	9	130	91	115	71.5	9	40	55	160	M8x14(n.8)	45°	8	31.3	12.7
040/075	11	140	93	119	71.5	10	40	60	165	M8x14(n.8)	45°	8	31.3	13.7
040/090	13	160	102	135	71.5	11	45	70	182	M10x18(n.8)	45°	10	38.3	17.3

(*) **Nota:** Il peso in kg si riferisce al motoriduttore ECMM 070 /...
Note: The weight in kg is referred to the gearmotor ECMM 070 /...



Dimensioni

Dimensions

ECMM070/...U

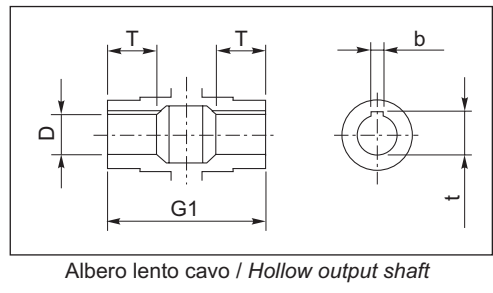
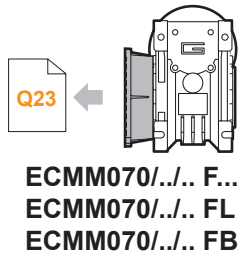
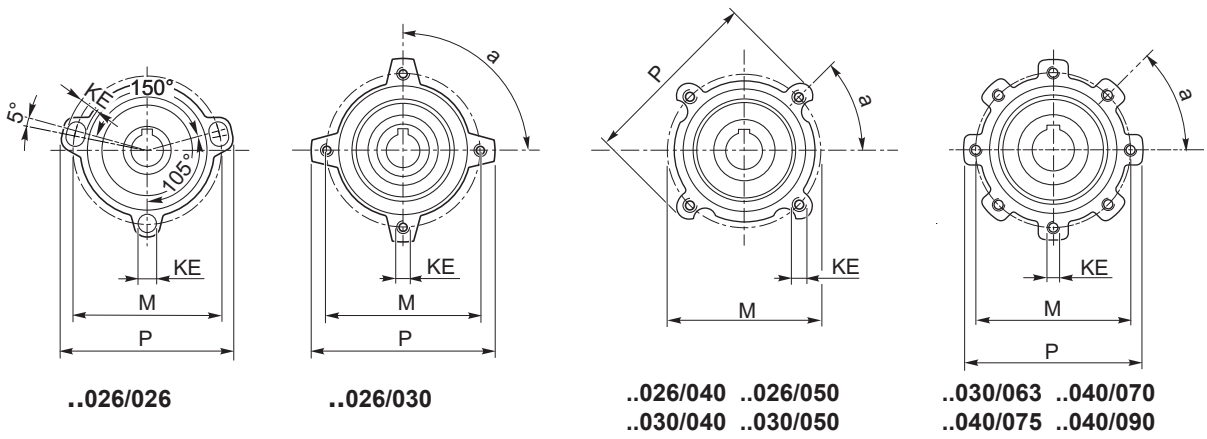
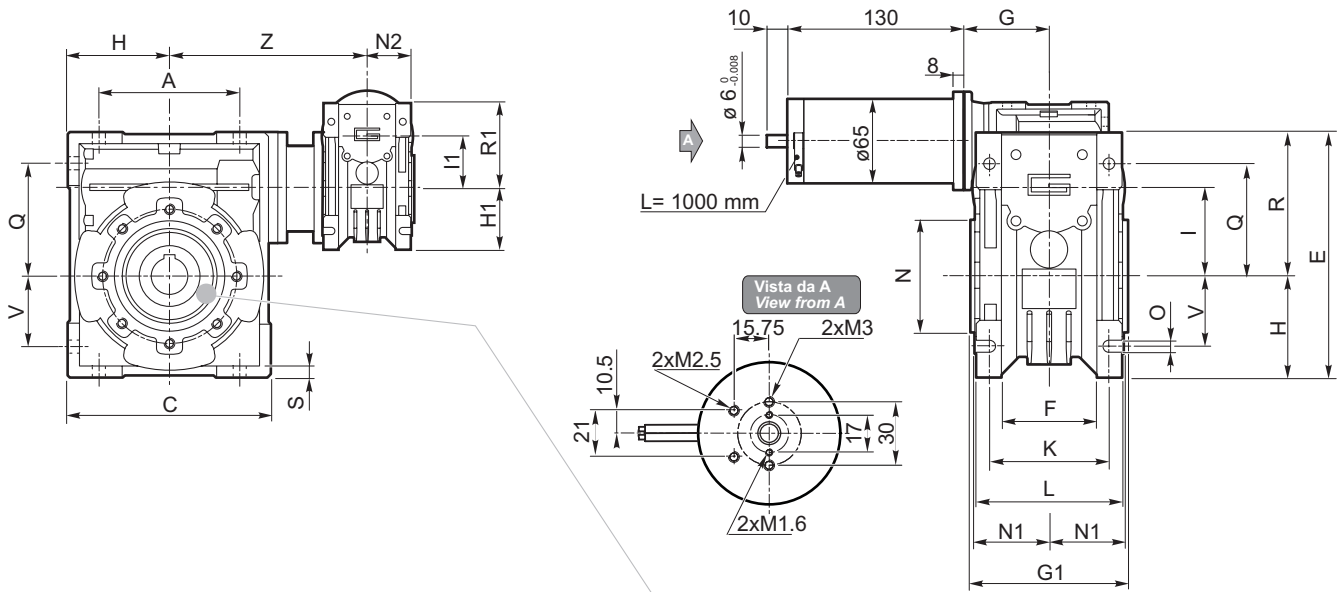

Motori / Motors IP66 → I2

Freno / Brake → H23

Encoder → H24

ECMM



Dimensioni

Dimensions

CMM..U - CMM..F...																	
	A	C	D _{H8}	E	F	G	G1	H	H1	I	I1	K	L	M	N _{H8}	N1	N2
026/026 (D11)	45	70	11	83	22	47.5	50	35	34	26	26	34	42	55	45	22.5	21
026/026			12														
026/026 (D14)			14														
026/030	54	80	14	97	32	47.5	63	40	34	30	26	44	56	65	55	29	21
026/040	70	100	18	121.5	43	47.5	78	50	34	40	26	60	71	75	60	36.5	21
026/050	80	120	25	144	49	47.5	92	60	34	50	26	70	85	85	70	43.5	21
030/040	70	100	18	121.5	43	55	78	50	40	40	30	60	71	75	60	36.5	29
030/050	80	120	25	144	49	55	92	60	40	50	30	70	85	85	70	43.5	29
030/063	100	144	25	174	67	55	112	72	40	63	30	85	104	95	80	53	29
040/070	110	160	28	195	64	70	120	80	50	70	40	90	104	115	95	57	35.5
040/075	120	172	28	205	72	70	120	86	50	75	40	90	112	115	95	57	36.5
040/090	140	208	35	238	74	70	140	103	50	90	40	100	130	130	110	67	36.5

CMM..U - CMM..F...														
	O	P	Q	R	R1	S	T	V	Z	KE	a	b	t	Kg (*)
026/026 (D11)	6	—	37	49	49	5	15	21	76	7	—	4	12.8	3.3
026/026												4	13.8	
026/026 (D14)												5	16.2	
026/030	6.5	75	44	57	49	5.5	22	27	81	M6x10(n.4)	90°	5	16.3	5.1
026/040	6.5	87	55	71.5	49	6.5	26	35	91.5	M6x8(n.4)	45°	6	20.8	6.2
026/050	8.5	98	64	84	49	7	30	40	100.5	M8x10(n.4)	45°	8	28.3	7.7
030/040	6.5	87	55	71.5	57	6.5	26	35	122	M6x8(n.4)	45°	6	20.8	6.6
030/050	8.5	98	64	84	57	7	30	40	132	M8x10(n.4)	45°	8	28.3	7.7
030/063	8.5	110	80	102	57	8	36	50	145	M8x14(n.8)	45°	8	28.3	9.7
040/070	9	130	91	115	71.5	9	40	55	160	M8x14(n.8)	45°	8	31.3	13.7
040/075	11	140	93	119	71.5	10	40	60	165	M8x14(n.8)	45°	8	31.3	14.7
040/090	13	160	102	135	71.5	11	45	70	182	M10x18(n.8)	45°	10	38.3	18.3

(*) **Nota:** Il peso in kg si riferisce al motoriduttore ECMM 100 /...
Note: The weight in kg is referred to the gearmotor ECMM 100 /...



Dimensioni

Dimensions

ECMM100/...U

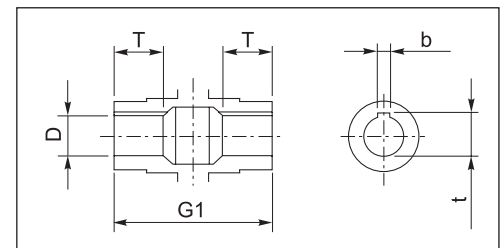
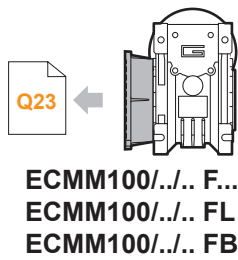
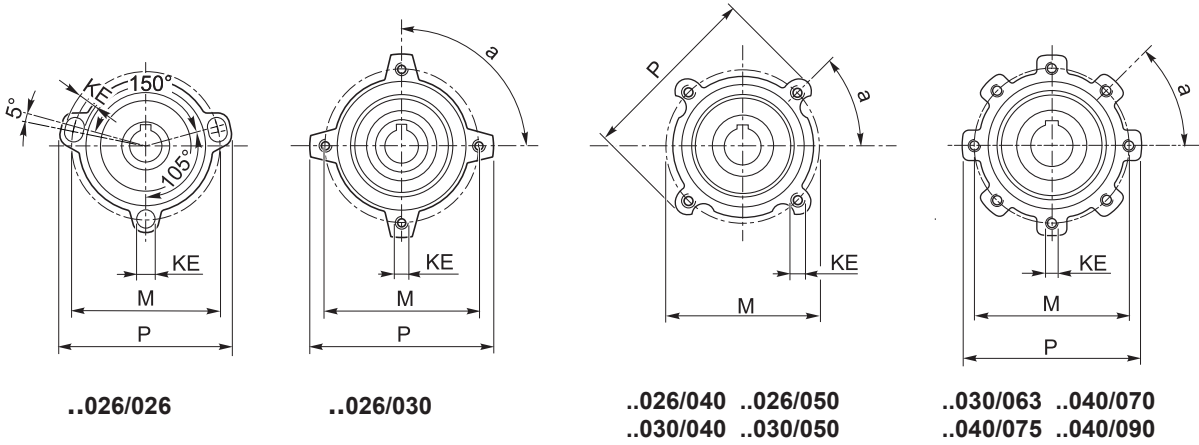
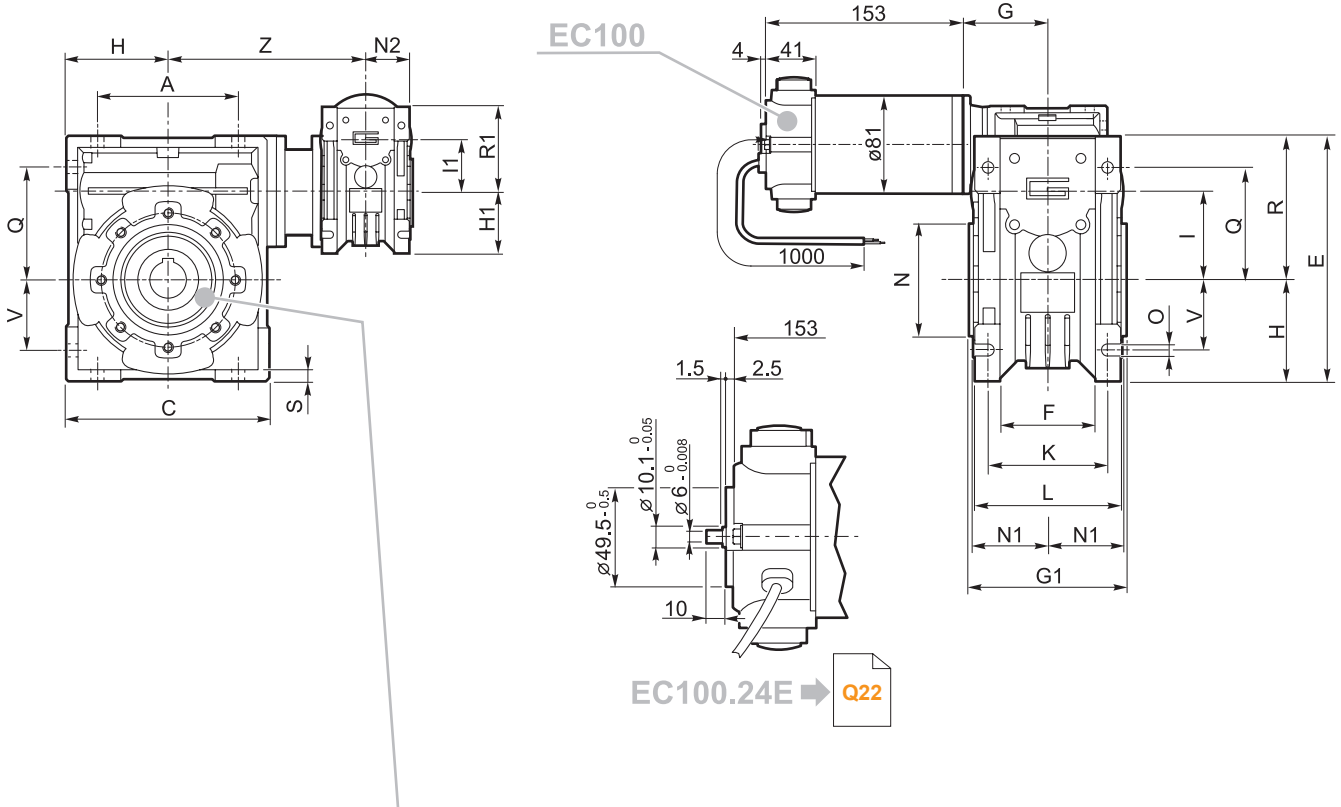

Albero lento cavo / Hollow output shaft

Motori / Motors IP66 → **14**

Freno / Brake → **H23**

Encoder → **H24**

Dimensioni
Dimensions

CMM..U - CMM..F - CMM..FB - CMM..FL																	
	A	C	D _{H8}	E	F	G	G1	H	H1	I	I1	K	L	M	N _{h8}	N1	N2
026/040	70	100	18	121.5	43	47.5	78	50	34	40	26	60	71	75	60	36.5	21
026/050	80	120	25	144	49	47.5	92	60	34	50	26	70	85	85	70	43.5	21
030/040	70	100	18	121.5	43	55	78	50	40	40	30	60	71	75	60	36.5	29
030/050	80	120	25	144	49	55	92	60	40	50	30	70	85	85	70	43.5	29
030/063	100	144	25	174	67	55	112	72	40	63	30	85	104	95	80	53	29
040/070	110	160	28	195	64	70	120	80	50	70	40	90	104	115	95	57	35.5
040/075	120	172	28	205	72	70	120	86	50	75	40	90	112	115	95	57	36.5
040/090	140	208	35	238	74	70	140	103	50	90	40	100	130	130	110	67	36.5
050/110	170	252.5	42	295	—	80	155	127.5	60	110	50	115	144	165	130	74	43.5

CMM..U - CMM..F - CMM..FB - CMM..FL															
	O	P	Q	R	R1	S	T	V	Z	KE	a	b	t	Kg (*)	
026/040	6.5	87	55	71.5	49	6.5	26	35	91.5	M6x8(n.4)	45°	6	20.8	6.9	
026/050	8.5	98	64	84	49	7	30	40	100.5	M8x10(n.4)	45°	8	28.3	8.4	
030/040	6.5	87	55	71.5	57	6.5	26	35	122	M6x8(n.4)	45°	6	20.8	7.3	
030/050	8.5	98	64	84	57	7	30	40	132	M8x10(n.4)	45°	8	28.3	8.4	
030/063	8.5	110	80	102	57	8	36	50	145	M8x14(n.8)	45°	8	28.3	10.4	
040/070	9	130	91	115	71.5	9	40	55	160	M8x14(n.8)	45°	8	31.3	14.4	
040/075	11	140	93	119	71.5	10	40	60	165	M8x14(n.8)	45°	8	31.3	15.4	
040/090	13	160	102	135	71.5	11	45	70	182	M10x18(n.8)	45°	10	38.3	19	
050/110	14	200	125	167.5	84	14	50	85	225	M10x18(n.8)	45°	12	45.3	33.6	

(*) **Nota:** Il peso in kg si riferisce al motoriduttore ECMM 180 /...

Note: The weight in kg is referred to the gearmotor ECMM 180 /...



Dimensioni

Dimensions

ECMM180/.../..U

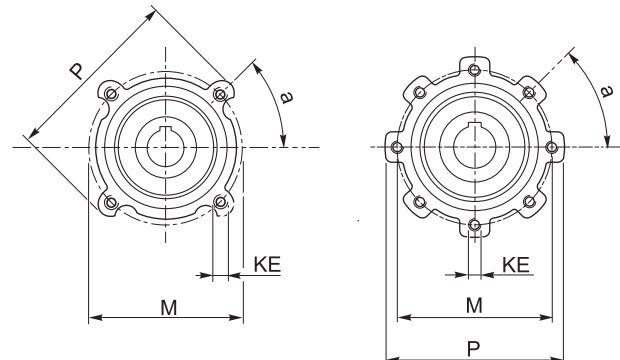
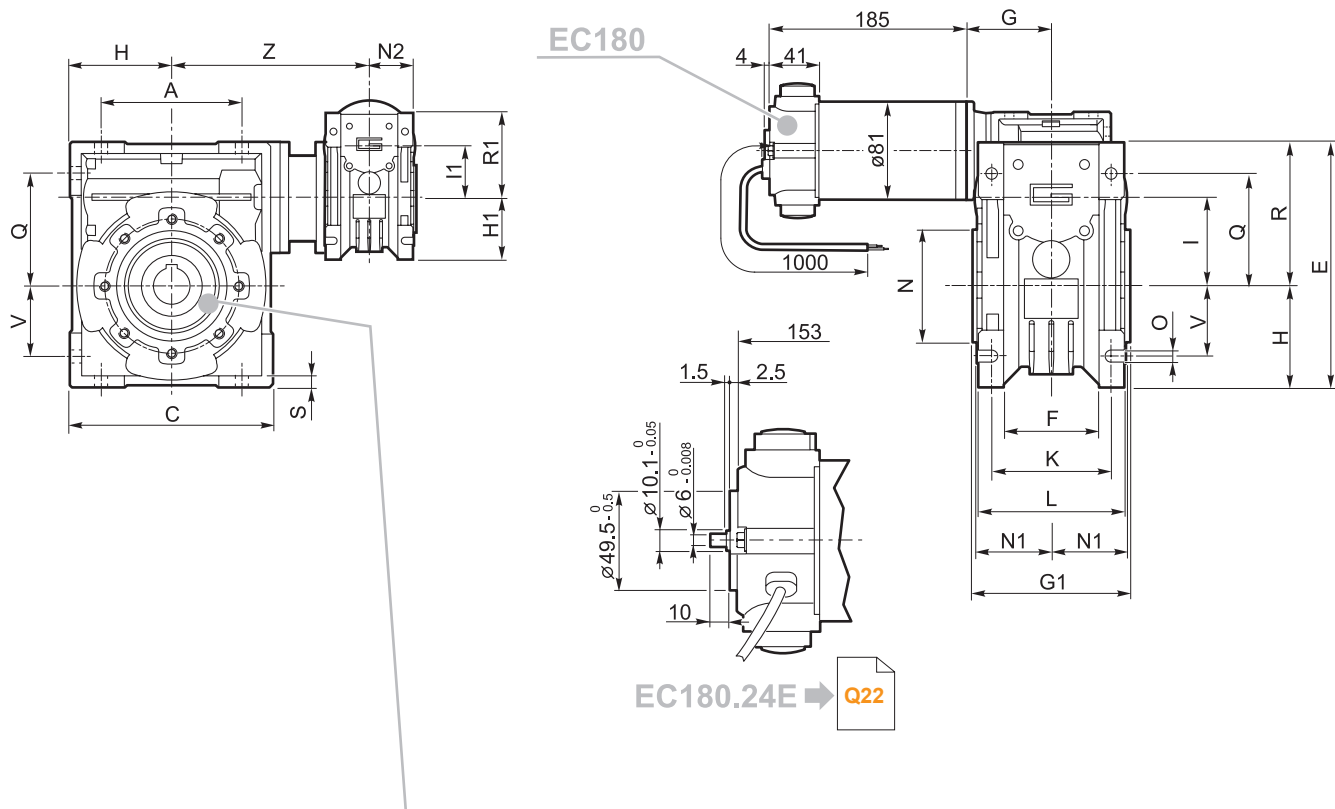

- | | | | |
|-----------|-----------|-----------|-----------|
| ..026/040 | ..026/050 | ..030/063 | ..040/070 |
| ..030/040 | ..030/050 | ..040/075 | ..040/090 |
| | | ..050/110 | |

Q23 →

ECMM180/.../.. F
ECMM180/.../.. FL
ECMM180/.../.. FB

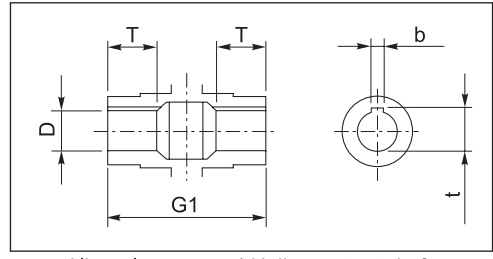

Motori / Motors IP66 → **16**

Freno / Brake → **H23**

Encoder → **H24**

ECMM

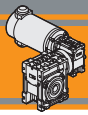

Dimensioni

Dimensions

CMM..U - CMM..F - CMM..FB - CMM..FL																	
	A	C	D _{H8}	E	F	G	G1	H	H1	I	I1	K	L	M	N _{H8}	N1	N2
030/040	70	100	18	121.5	43	55	78	50	40	40	30	60	71	75	60	36.5	29
030/050	80	120	25	144	49	55	92	60	40	50	30	70	85	85	70	43.5	29
030/063	100	144	25	174	67	55	112	72	40	63	30	85	104	95	80	53	29
040/070	110	160	28	195	64	70	120	80	50	70	40	90	104	115	95	57	35.5
040/075	120	172	28	205	72	70	120	86	50	75	40	90	112	115	95	57	36.5
040/090	140	208	35	238	74	70	140	103	50	90	40	100	130	130	110	67	36.5
050/110	170	252.5	42	295	—	80	155	127.5	60	110	50	115	144	165	130	74	43.5

CMM..U - CMM..F - CMM..FB - CMM..FL															
	O	P	Q	R	R1	S	T	V	Z	KE	a	b	t	Kg (*)	
030/040	6.5	87	55	71.5	57	6.5	26	35	122	M6x8(n.4)	45°	6	20.8	8.2	
030/050	8.5	98	64	84	57	7	30	40	132	M8x10(n.4)	45°	8	28.3	9.3	
030/063	8.5	110	80	102	57	8	36	50	145	M8x14(n.8)	45°	8	28.3	11.3	
040/070	9	130	91	115	71.5	9	40	55	160	M8x14(n.8)	45°	8	31.3	15.3	
040/075	11	140	93	119	71.5	10	40	60	165	M8x14(n.8)	45°	8	31.3	16.3	
040/090	13	160	102	135	71.5	11	45	70	182	M10x18(n.8)	45°	10	38.3	19.9	
050/110	14	200	125	167.5	84	14	50	85	225	M10x18(n.8)	45°	12	45.3	34.5	

(*) **Nota:** Il peso in kg si riferisce al motoriduttore ECMM 250 /...
Note: The weight in kg is referred to the gearmotor ECMM 250 /...



Dimensioni

Dimensions

ECMM250/...U

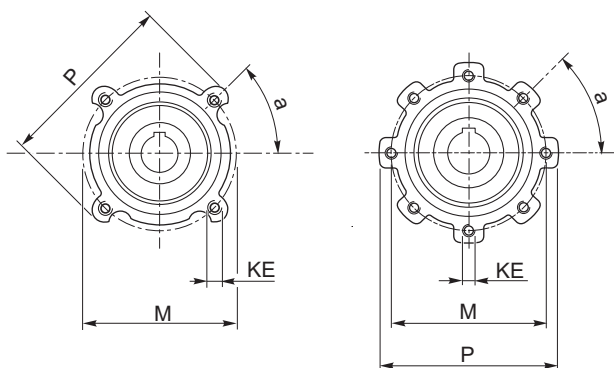
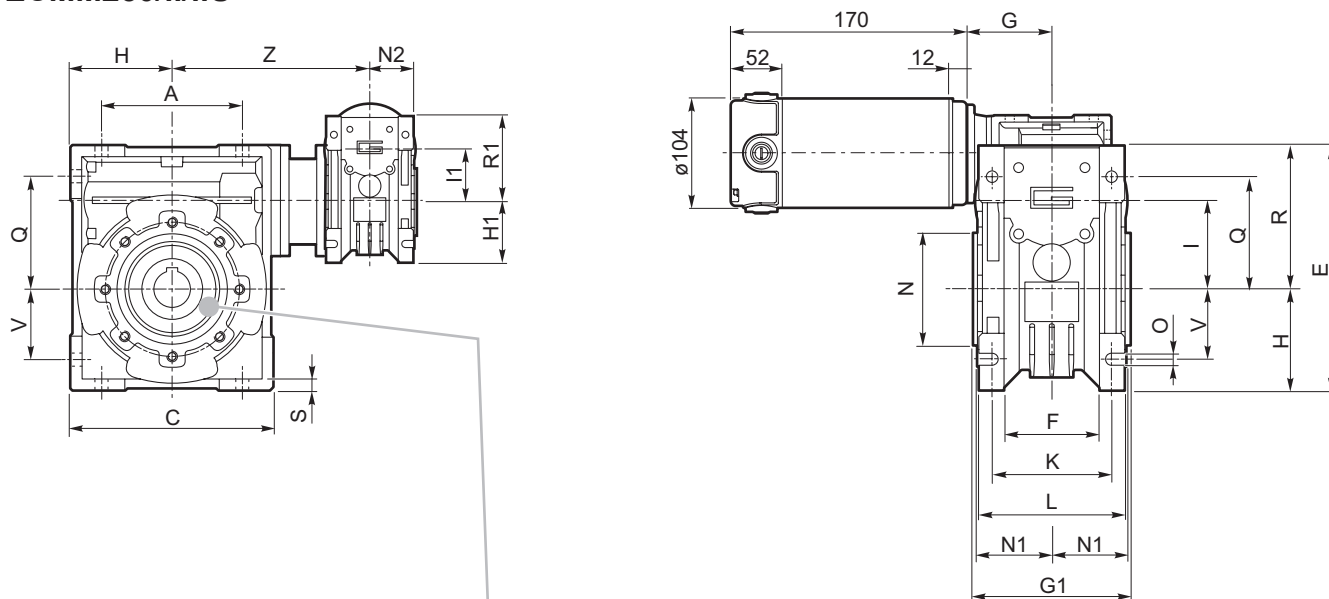

..030/040 ..030/050

..030/063 ..040/070
..040/075 ..040/090
..050/110

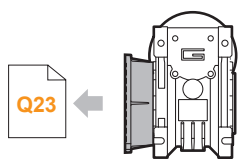

ECMM250/... F
ECMM250/... FL
ECMM250/... FB

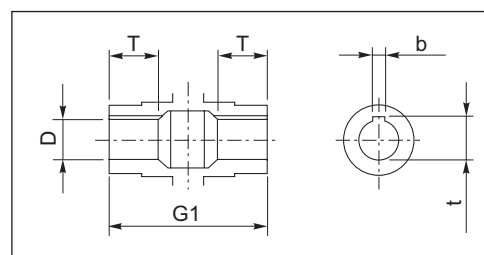

Albero lento cavo / Hollow output shaft

Motori / Motors IP66

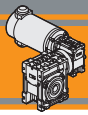

Dimensioni
Dimensions

CMM..U - CMM..F - CMM..FB - CMM..FL																	
	A	C	D _{H8}	E	F	G	G1	H	H1	I	I1	K	L	M	N _{H8}	N1	N2
030/040	70	100	18	121.5	43	55	78	50	40	40	30	60	71	75	60	36.5	29
030/050	80	120	25	144	49	55	92	60	40	50	30	70	85	85	70	43.5	29
030/063	100	144	25	174	67	55	112	72	40	63	30	85	104	95	80	53	29
040/070	110	160	28	195	64	70	120	80	50	70	40	90	104	115	95	57	35.5
040/075	120	172	28	205	72	70	120	86	50	75	40	90	112	115	95	57	36.5
040/090	140	208	35	238	74	70	140	103	50	90	40	100	130	130	110	67	36.5
050/110	170	252.5	42	295	—	80	155	127.5	60	110	50	115	144	165	130	74	43.5
063/130	200	292.5	45	335	—	95	170	147.5	72	130	63	120	155	215	180	81	53

CMM..U - CMM..F - CMM..FB - CMM..FL															
	O	P	Q	R	R1	S	T	V	Z	KE	a	b	t	Kg (*)	
030/040	6.5	87	55	71.5	57	6.5	26	35	122	M6x8(n.4)	45°	6	20.8	9.2	
030/050	8.5	98	64	84	57	7	30	40	132	M8x10(n.4)	45°	8	28.3	10.3	
030/063	8.5	110	80	102	57	8	36	50	145	M8x10(n.8)	45°	8	28.3	12.3	
040/070	9	130	91	115	71.5	9	40	55	160	M8x14(n.8)	45°	8	31.3	16.3	
040/075	11	140	93	119	71.5	10	40	60	165	M8x14(n.8)	45°	8	31.3	17.3	
040/090	13	160	102	135	71.5	11	45	70	182	M10x18(n.8)	45°	10	38.3	20.9	
050/110	14	200	125	167.5	84	14	50	85	225	M10x18(n.8)	45°	12	45.3	35.5	
063/130	16	250	140	187.5	102	15	60	100	245	M12x21(n.8)	45°	14	48.8	60.3	

(*) **Nota:** Il peso in kg si riferisce al motoriduttore ECMM 350 /...

Note: The weight in kg is referred to the gearmotor ECMM 350 /...



Dimensioni

Dimensions

ECMM350/...U

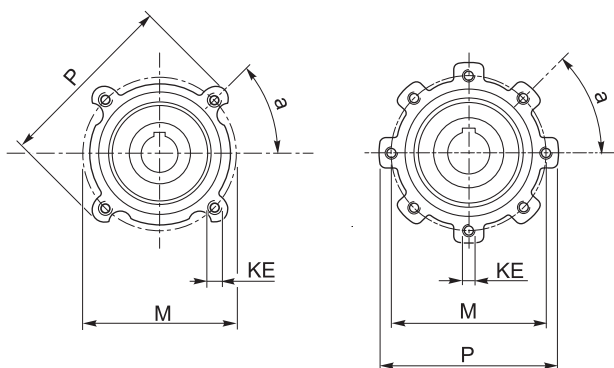
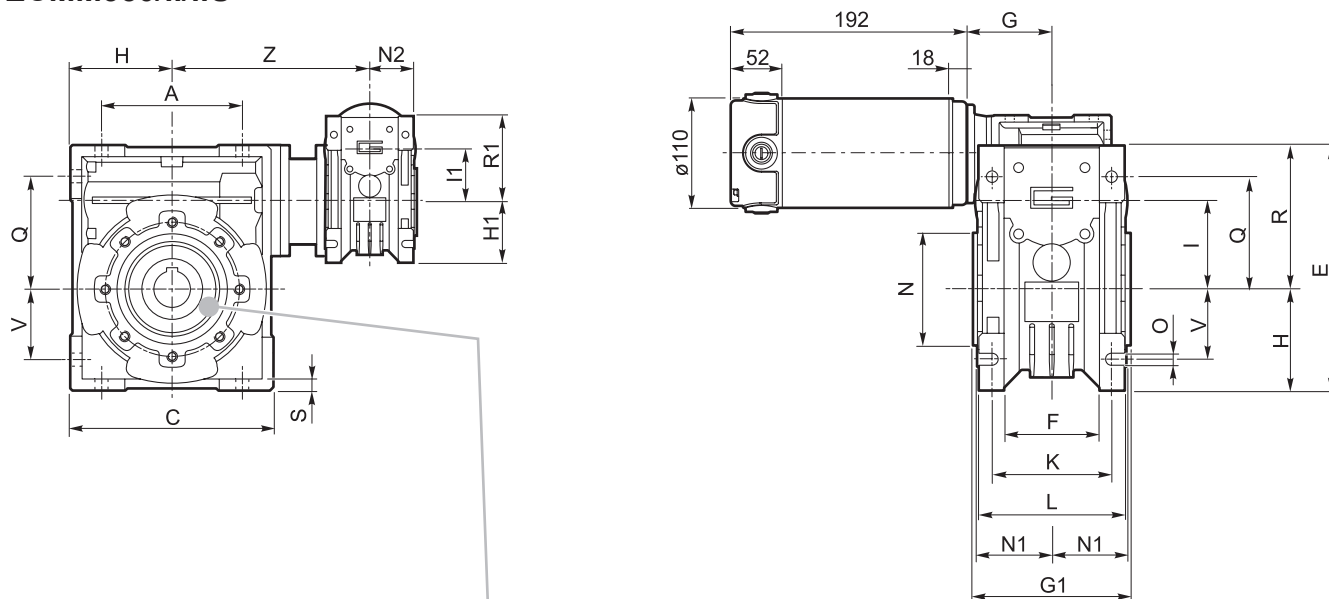

..030/040 ..030/050

..030/063 ..040/070
..040/075 ..040/090
..050/110 ..063/130

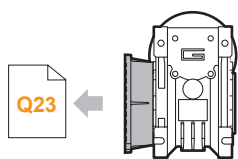

ECMM350/... F
ECMM350/... FL
ECMM350/... FB

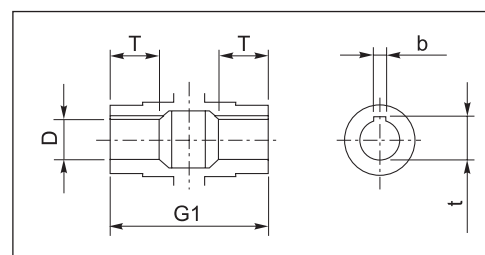

Albero lento cavo / Hollow output shaft

Motori / Motors IP66 → **I10**

Freno / Brake → **H23**

**Dimensioni****Dimensions**

CMM..U - CMM..F - CMM..FB - CMM..FL																	
	A	C	D _{H8}	E	F	G	G1	H	H1	I	I1	K	L	M	N _{H8}	N1	N2
040/070	110	160	28	195	64	70	120	80	50	70	40	90	104	115	95	57	35.5
040/075	120	172	28	205	72	70	120	86	50	75	40	90	112	115	95	57	36.5
040/090	140	208	35	238	74	70	140	103	50	90	40	100	130	130	110	67	36.5
050/110	170	252.5	42	295	—	80	155	127.5	60	110	50	115	144	165	130	74	43.5
063/130	200	292.5	45	335	—	95	170	147.5	72	130	63	120	155	215	180	81	53

CMM..U - CMM..F - CMM..FB - CMM..FL															
	O	P	Q	R	R1	S	T	V	Z	KE	a	b	t	Kg (*)	
040/070	9	130	91	115	71.5	9	40	55	160	M8x14(n.8)	45°	8	31.3	18.3	
040/075	11	140	93	119	71.5	10	40	60	165	M8x14(n.8)	45°	8	31.3	19.3	
040/090	13	160	102	135	71.5	11	45	70	182	M10x18(n.8)	45°	10	38.3	22.7	
050/110	14	200	125	167.5	84	14	50	85	225	M10x18(n.8)	45°	12	45.3	37.3	
063/130	16	250	140	187.5	102	15	60	100	245	M12x21(n.8)	45°	14	48.8	62.1	

(*) **Nota:** Il peso in kg si riferisce al motoriduttore ECMM 600 /...

Note: The weight in kg is referred to the gearmotor ECMM 600 /...



Dimensioni

Dimensions

ECMM600/...U

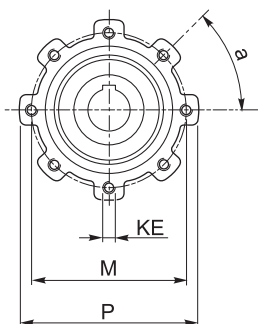
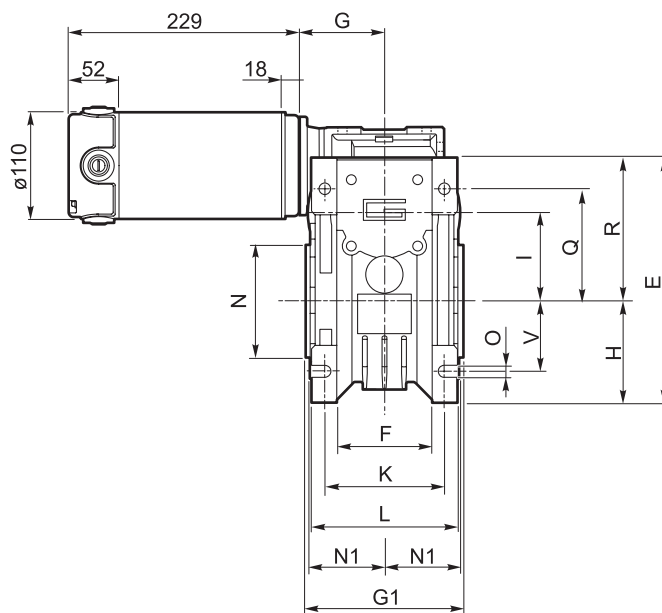
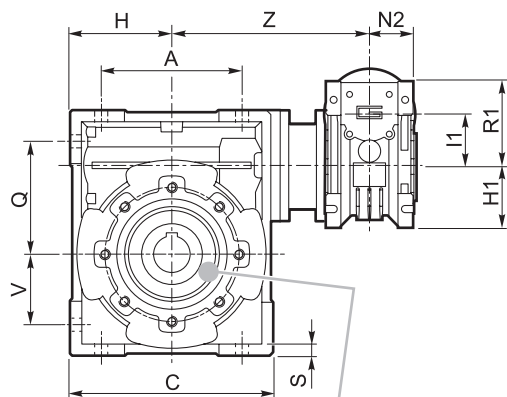

..040/070 ..040/075
..040/090 ..050/110
..063/130

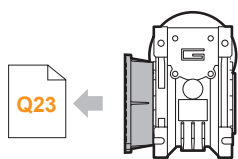

ECMM600/... F
ECMM600/... FL
ECMM600/... FB

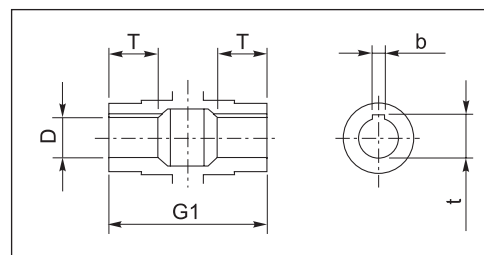

Albero lento cavo / Hollow output shaft

Motori / Motors IP66

→ I12

Freno / Brake

→ H23

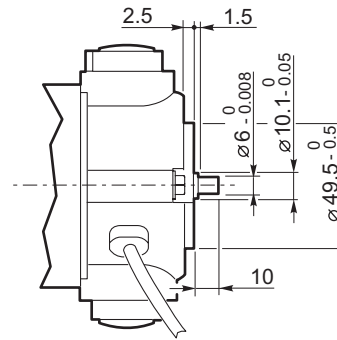
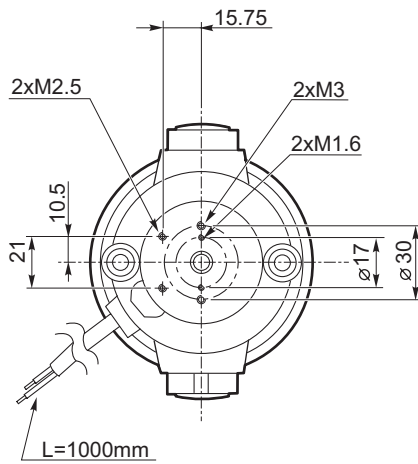
**Dimensioni****Dimensions****EC100.24E**
EC180.24E



Dimensioni

Dimensions

ECMM.../... F... Flange uscita / Output flanges

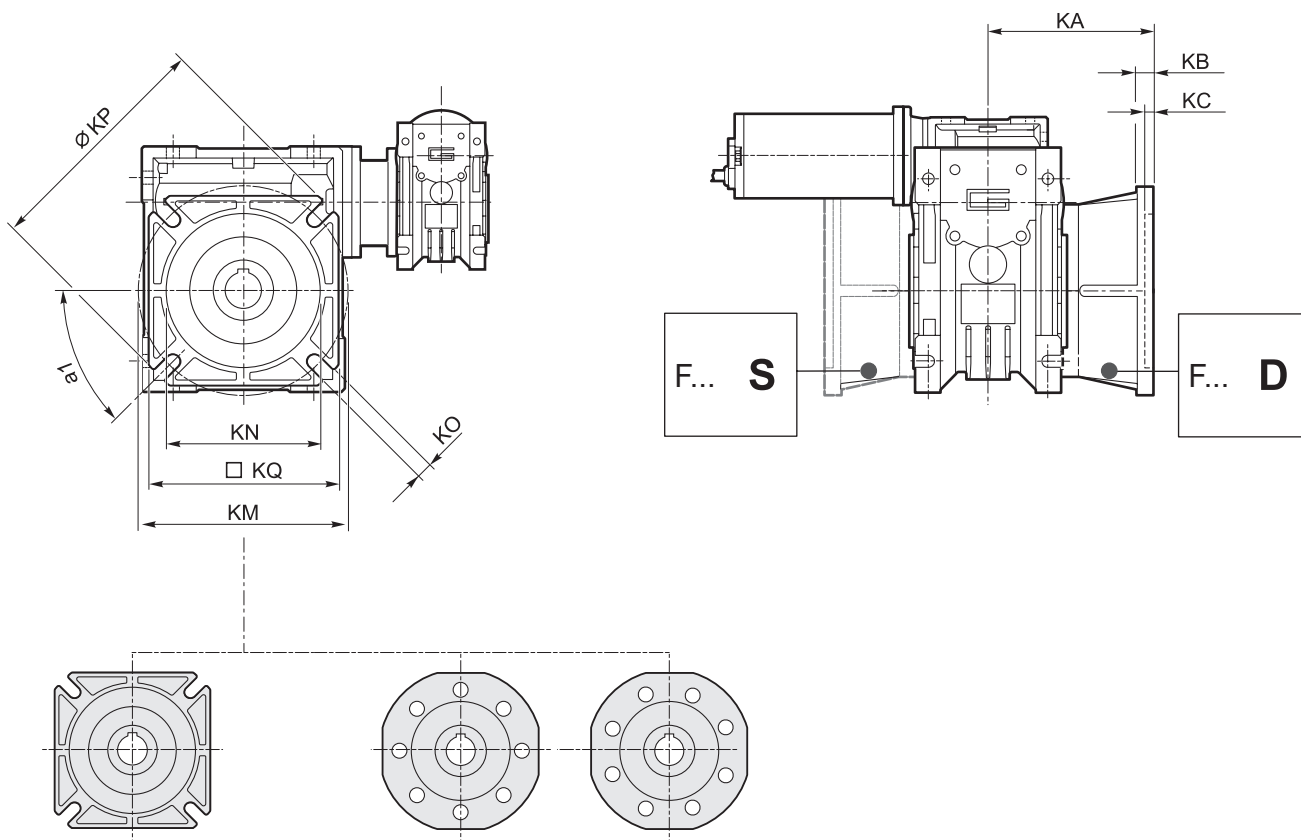

CMM..F...

(../026 - ../030 - ../040 - ../050
../063 - ../070 - ../075 - ../090)

CMM..F

(../110) (../130)

	CMM..F								CMM..F28						CMM..F30										
	a1	KA	KB	KC	KM	KN _{H8}	KO	KP	KQ	KA	KB	KC	KM	KN _{H8}	KO	KP	KQ	KA	KB	KC	KM	KN _{H8}	KO	KP	KQ
026/026 (D11)	45°	45	6	4.5	55-69	40	6.5(n.4)	75	70	44	6.5	5	56-64	40	6.5	70	60	48	6.5	5	68	50	6.5	80	70
026/026																									
026/026 (D14)																									

	CMM..F								CMM..FB						CMM..FL										
	a1	KA	KB	KC	KM	KN _{H8}	KO	KP	KQ	KA	KB	KC	KM	KN _{H8}	KO	KP	KQ	KA	KB	KC	KM	KN _{H8}	KO	KP	KQ
026/030	45°	54.5	6	4	68	50	6.5(n.4)	80	70	—	—	—	—	—	—	—	—	—	—	—	—	—	—	—	—
026/040	45°	67	7.5	4.5	80-95	60	9(n.4)	110	95	80	8.5	5	115-125	95	9.5(n.4)	140	112	97	7.5	4.5	80-95	60	9(n.4)	110	95
030/040																									
026/050	45°	90	9	5	90-110	70	11(n.4)	125	110	89	9	5	130-145	110	9.5(n.4)	160	132	120	9	5	90-110	70	11(n.4)	125	110
030/050																									
030/063	45°	82	10	6	150-160	115	11(n.4)	180	142	98	10	5	165-180	130	11(n.4)	200	112	112	10	6	150-160	115	11(n.4)	180	142
040/070	45°	107	13	6	165-180	130	14(n.4)	200	170	—	—	—	—	—	—	—	—	—	—	—	—	—	—	—	—
040/075	45°	111	13	6	165-180	130	14(n.4)	200	170	—	—	—	—	—	—	—	—	—	—	—	—	—	—	—	—
040/090	45°	111	13	6	175-190	152	14(n.4)	210	200	—	—	—	—	—	—	—	—	—	—	—	—	—	—	—	—
050/110	45°	131	15	6	230	170	14(n.8)	280	260	—	—	—	—	—	—	—	—	—	—	—	—	—	—	—	—
063/130	22.5°	140	15	6	255	180	16(n.8)	320	290	—	—	—	—	—	—	—	—	—	—	—	—	—	—	—	—

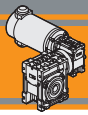

Accessori

Accessories

Albero lento semplice e doppio

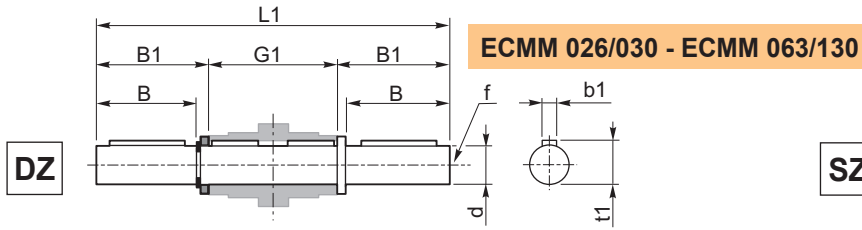

Single and double output shaft

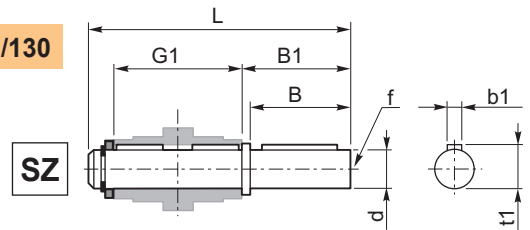

ECMM	d _{h7}	B	B1	G1	L	L1	f	b1	t1
026/030	14	30	32.5	63	102	128	M6	5	16
026/040	18	40	43	78	128	164	M6	6	20.5
030/040									
026/050	25	50	53.5	92	153	199	M10	8	28
030/050									
030/063	25	50	53.5	112	173	219	M10	8	28
040/070	28	60	63.5	120	192	247	M10	8	31
040/075	28	60	63.5	120	192	247	M10	8	31
040/090	35	80	84.5	140	234	309	M12	10	38
050/110	42	80	84.5	155	249	324	M16	12	45
063/130	45	80	85	170	265	340	M16	14	48.5

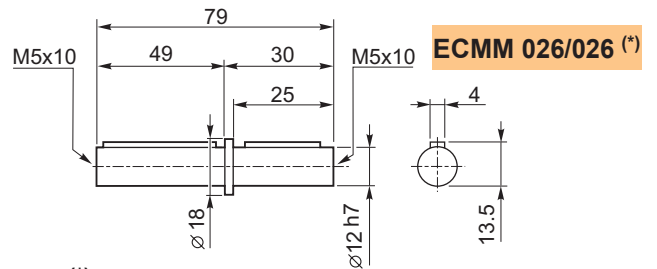

(*)
Nota: disponibile solo per cavo uscita Ø12
Note: available for output hollow shaft Ø12 only

Braccio di reazione

ECMM	K1	G	KG	KH	R
026/030	85	14	23	8	15
026/040	100	14	31	10	18
030/040					
026/050	100	14	38	10	18
030/050					
030/063	150	14	47.5	10	18
040/070	200	25	46.5	20	30
040/075	200	25	46.5	20	30
040/090	200	25	56.5	20	30
050/110	250	30	62	25	35
063/130	250	30	69	25	35

Torque arm

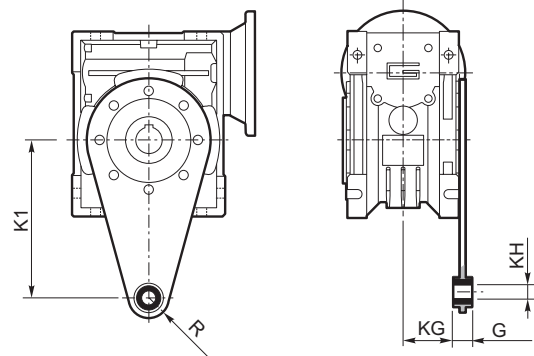

Opzioni

Options

VS1 - VS2 - Vite sporgente / Extended input shaft

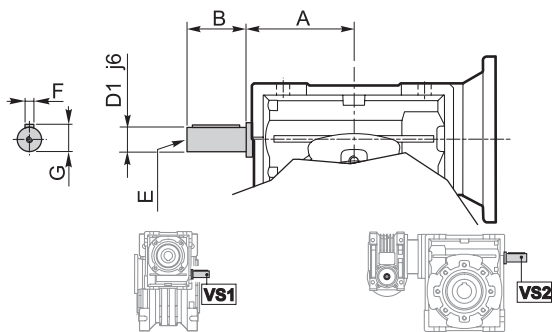

CMM	VS1						VS2					
	A	B	D ₁ j6	E	F	G	A	B	D ₁ j6	E	F	G
026/030	—	—	—	—	—	—	45	20	9	M4	3	10.2
026/040	—	—	—	—	—	—	53	23	11	M5	4	12.5
026/050	—	—	—	—	—	—	64	30	14	M6	5	16
030/040	45	20	9	M4	3	10.2	53	23	11	M5	4	12.5
030/050	45	20	9	M4	3	10.2	64	30	14	M6	5	16
030/063	45	20	9	M4	3	10.2	75	40	19	M6	6	21.5
040/070	53	23	11	M5	4	12.5	84	40	19	M6	6	21.5
040/075	53	23	11	M5	4	12.5	90	50	24	M8	8	27
040/090	53	23	11	M5	4	12.5	108	50	24	M8	8	27
050/110	64	30	14	M6	5	16	135	60	28	M10	8	31
063/130	75	40	19	M6	6	21.5	—	—	—	—	—	—

SC - Safety cover

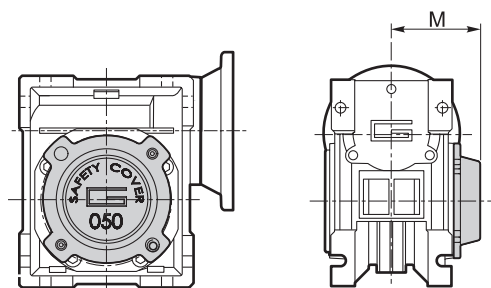

M	CM								
	30	40	50	63	70	75	90	110	130
	47	54.5	62.5	73	79	79	94	102	117

Costruito su richiesta
Built on request



Azionamenti per motori CC DC motor controls



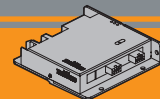

	Indice	Index	Pag. Page
PLN19-8	Schema dei collegamenti	<i>Main connection diagram</i>	R2
	Caratteristiche tecniche	<i>Technical features</i>	R2
	Dimensioni	<i>Dimensions</i>	R3
	Opzioni	<i>Options</i>	R3
PLN20 PLN40	Schema dei collegamenti	<i>Main connection diagram</i>	R4
	Caratteristiche tecniche	<i>Technical features</i>	R5
	Dotazioni	<i>Equipment</i>	R5
	Manuale	<i>User manual</i>	R5
	Dimensioni	<i>Dimensions</i>	R6
	GUIDA alla selezione dell'azionamento	<i>Drive selection GUIDE</i>	R7
	Note	<i>Note</i>	R8

Questa sezione annulla e sostituisce ogni precedente edizione o revisione. Qualora questa sezione non Vi sia giunta in distribuzione controllata, l'aggiornamento dei dati ivi contenuto non è assicurato. **In tal caso la versione più aggiornata è disponibile sul nostro sito internet www.transtecno.com**

This section replaces any previous edition and revision. If you obtained this catalogue other than through controlled distribution channels, the most up to date content is not guaranteed. In this case the latest version is available on our web site www.transtecno.com

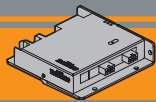

**AZIONAMENTO UNIDIREZIONALE PWM PER LA
REGOLAZIONE DI VELOCITA' DEI MOTORI A
CORRENTE CONTINUA A BASSA TENSIONE**

**LOW VOLTAGE SINGLE DIRECTION
PWM DC MOTORS CONTROL**

SCHEMA DEI COLLEGAMENTI - MAIN CONNECTION DIAGRAM

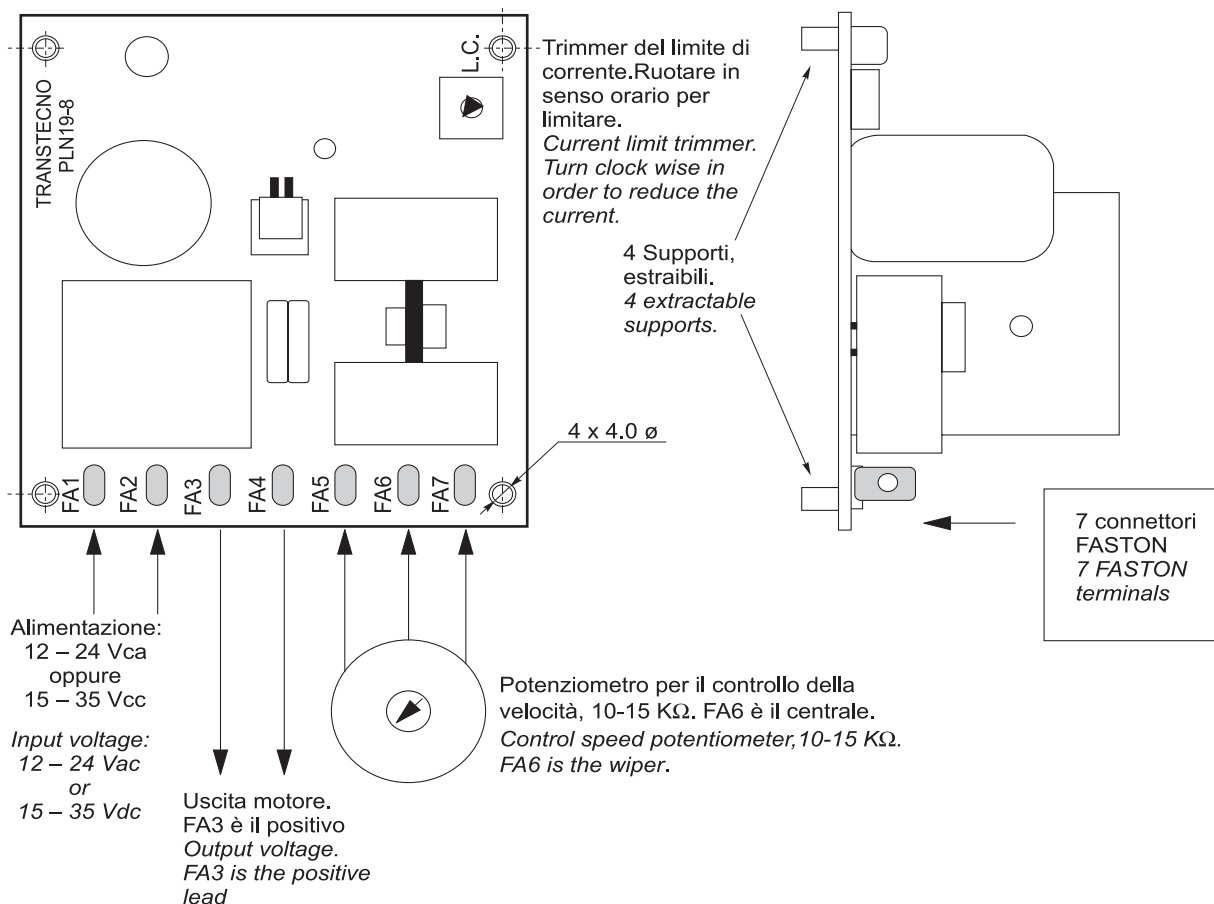

Attenzione: se si scollega il potenziometro con la scheda alimentata, il motore ruota alla velocità nominale.

Warning: if speed pot is disconnected when the board is powered, the motor runs at its maximum speed.

Caratteristiche tecniche

Technical features

- Alimentazione ai terminali FA1 e FA2:
12 - 24 Vca oppure 15 - 35 Vcc.
- Regolazione della velocità mediante potenziometro 10-15 KΩ.
- Trimmer di Limitazione della corrente, per adattare la scheda anche a motori di piccole potenze. Per limitare l'erogazione di corrente, ruotare in senso orario il trimmer.
- Uscita motore ai terminali FA3 e FA4, regolabile da 0 a Vcc MAX che è proporzionale alla tensione di ingresso. Con 35 Vcc di alimentazione, l'uscita MAX è circa 30 Vcc.
- Corrente di uscita (*): Massima corrente ammessa: 8 A in ambiente ventilato, servizio continuo.
- Peso: 0.120 Kg.
- Line voltage at terminals FA1 and FA2:
12 – 24 Vac or 15 – 35 Vdc.
- The speed of the drive is to be controlled by potentiometer, 10-15 KΩ.
- Current Limit trimmer, in order to suit the board for small motors. In order to limit the current, turn clock wise the trimmer.
- Output voltage from terminals FA3 and FA4, from 0 up to Vdc MAX which is proportional to the input voltage. With 35 Vdc input voltage, the max output voltage is about 30 Vdc.
- Output current (*): Maximum output current allowed: 8 A in a ventilated environment, continuous duty.
- Weight: 0.120 Kg.

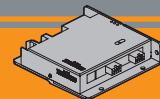

Dimensioni

Dimensions

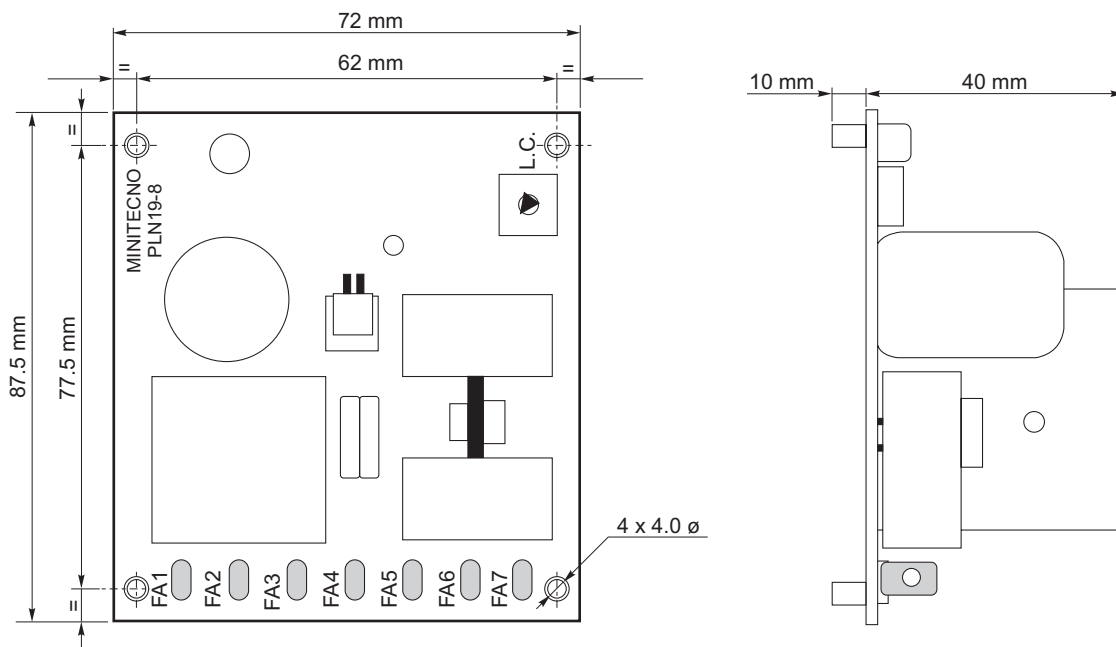

Opzioni

Options

1. Potenzimetro 10 k Ω
2. Supporto per montaggio su guida DIN

1. Speed potentiometer 10 k Ω
2. DIN mounting support

(*) il valore massimo di corrente motore deve essere utilizzato in **ambiente ventilato**. In ambienti non ventilati e per temperatura ambiente di 45 °C, ridurre la corrente motore massima a 4 A; servizio continuo.

(*) *the maximum output current value must be used in a ventilated environment. Derate the maximum output current down to 4 A if the environment is not ventilated and the temperature is about 45 °C; continuous duty.*

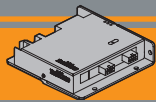

AZIONAMENTO BIDIREZIONALE PWM PER LA REGOLAZIONE DI VELOCITA' DEI MOTORI A CORRENTE CONTINUA A BASSA TENSIONE

LOW VOLTAGE BIDIRECTIONAL PWM DC MOTORS CONTROL

SCHEMA DEI COLLEGAMENTI - MAIN CONNECTION DIAGRAM

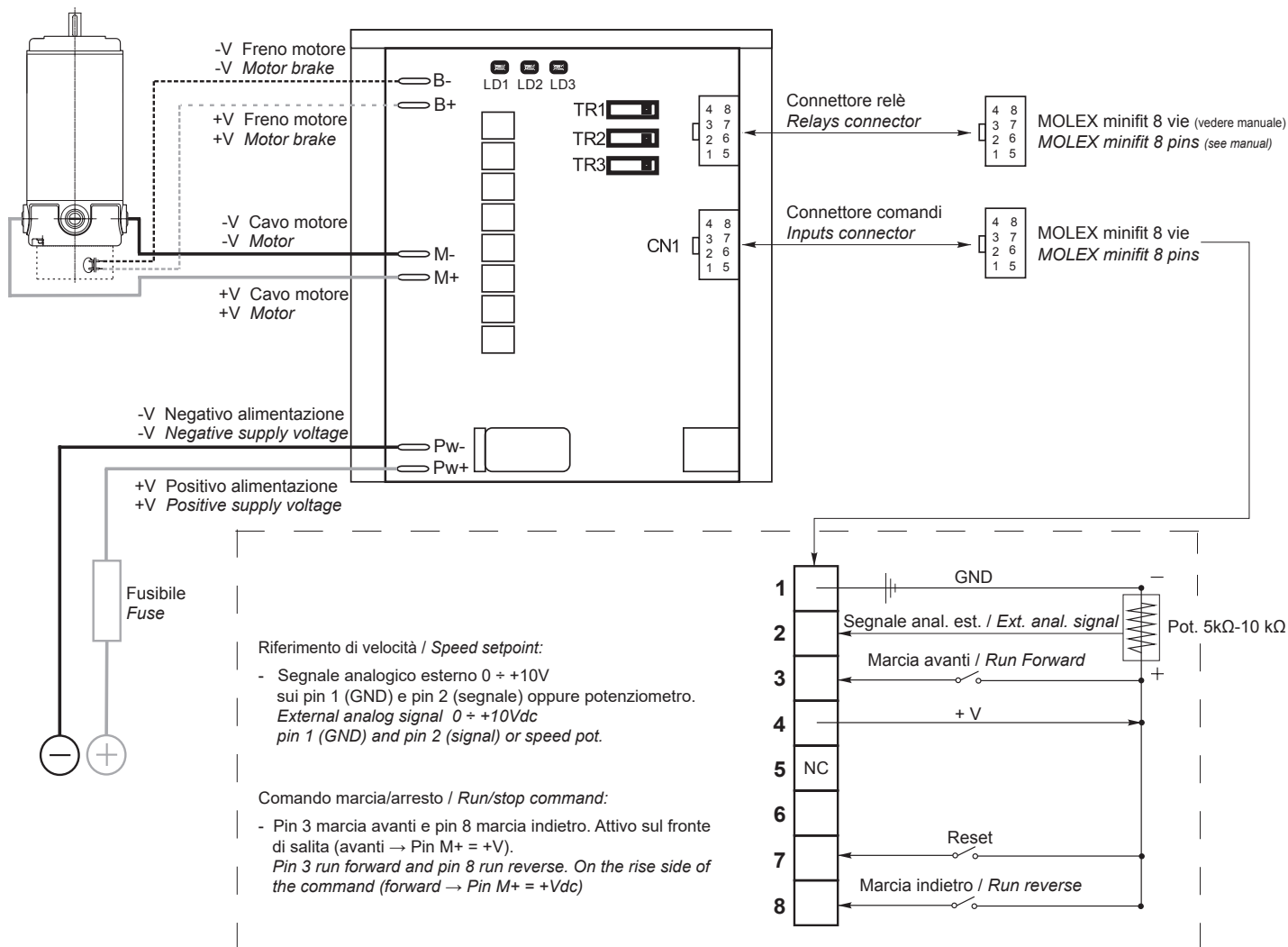

Fusibile:

150-200% della corrente motore. Max 3 volte la corrente nominale della scheda, con intervento entro pochi secondi.

Fuse:

150-200 % rated motor current. Max 3 times rated current of the drive (trip time in few seconds).

Trimmer multigiro:

TR1: Accelerazione: selezione da 0.5 a 10 sec.

TR2: Limite di corrente: riduce il limite di corrente nominale da 100% a circa 30% (corrente di picco 3 volte la corrente selezionata).

TR3: Decelerazione: selezione da 0.5 a 10 sec.

Multiturn trimmers:

TR1: Acceleration time: from 0.5 to 10 sec.

TR2: Current limitation: rated current limited from 100% to about 30% (peak current 3 times the selected limited current).

TR3: Deceleration time: from 0.5 to 10 sec.

LED:

LD1: Visualizza lo stato di funzionamento con limite di corrente attivo (il motore assorbe più della corrente selezionata e l'azionamento opera in limitazione).

LD2: Stato dell'azionamento: lampeggio veloce e continuo = funzionamento normale, lampeggio lento e codificato = presenza di un allarme

LD3: Segnalazione presenza alimentazione.

LED:

LD1: ON when the drive runs under current limitation (motor requires more than the rated current and drive supplies only limited current).

LD2: Status: quick continuous flash = drive ok, slow coded flash = fault).

LD3: Power ON

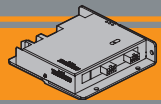

Caratteristiche tecniche

Technical features

- Scheda bidirezionale a transistor a ricircolo di corrente.
 - Selezionabili i seguenti parametri (mediante trimmer):
 - rampa di accelerazione: 0.5 - 10 sec
 - rampa di decelerazione: 0.5 - 10 sec
 - limite corrente 100%-30% circa
 - Temperatura di lavoro: 0°C / +40°C (allarme sotto zero)
 - Diagnostica tramite LED
 - Frequenza di commutazione: 16kHz
 - Dotata di coperchio
 - Velocità regolabile con potenziometro 5-10 kΩ o con segnale 0-10 Vcc
 - Limitazione della corrente regolabile
 - Sensore termico di protezione
- *Transistor bidirectional drive with regenerative current system.*
 - *Following settings can be adjusted (by built in trimmers):*
 - *acceleration ramp: 0.5 - 10 sec*
 - *deceleration ramp: 0.5 - 10 sec*
 - *current limit 100% - about 30%*
 - *Room temperature: 0°C / +40°C (alarm below zero)*
 - *LED for system diagnosis*
 - *Switching frequency: 16kHz*
 - *Covered*
 - *5-10 kΩ Speed pot. or 0-10 Vdc external signal for speed re-
gulation*
 - *Variable current limit*
 - *Thermal sensor for protection*

Modello Model number	Tensione di alimentazione DC input voltage [Vdc]	Tensione di uscita Motor voltage [Vdc]*	Corrente di uscita nominale DC load current [A]	Corrente di picco motore Maximum load current [A]**	Campo di alimentazione Power supply range [Vdc]
PLN20	12 ÷ 24	0 ÷ Vin	20	60 (4 sec)	10 ÷ 30
PLN40	12 ÷ 24	0 ÷ Vin	40	120 (1 sec)	10 ÷ 30

* L'azionamento riduce la tensione nominale di 1-2 Vcc. Il fenomeno è normale e fisiologico. Se serve ottenere 24 ÷ 12 Vcc in uscita sotto ogni condizione di carico, si suggerisce di sovralimentare di un paio di volt.

** Un timer impone il limite con un andamento temporale iperbolico, cioè quanta più corrente eroga e tanto meno è il tempo per il quale ciò è ammesso, prima che appunto la scheda vada in limitazione. Alla corrente di picco (x 3 volte quella nominale) la scheda funziona per pochi secondi.

* *The drive reduces the rated voltage of 1-2 Vdc. This is normal and physiological. If 24 ÷ 12 VDC output is required under all load conditions, it is advisable to supercharge a couple of volts.*

** *A timer imposes a limit with a temporary hyperbolic performance, which means the more current is requested, the less time is permitted with this current before the drive is limited. When the current reaches its peak (3 times the rated value) the drive will work for a few seconds.*

Dotazioni

Equipment

	PLN20	PLN40
Trimmer di selezione ACCEL, DECEL e LIMITE di CORRENTE / <i>Selection Trimmer ACCEL, DECEL, CURRENT LIMIT</i>	■	■
2 contatti: marcia avanti e marcia indietro / <i>2 contacts : forward and reverse</i>	■	■
Riferimento di velocità / <i>Speed setpoint reference</i>	■	■
3 LEDs di segnalazione / <i>3 LEDs signals</i>	■	■
Segnale di comando di eventuale freno negativo di stazionamento / <i>Command signal for possible negative electromagnetic brake</i>	■	■
Predisposizione per montaggio a libro e a zoccolo / <i>Arranged for 2 different ways of mounting</i>	■	■
Memorizzazione e segnalazione degli allarmi / <i>Memory storage and report of alarm</i>	■	■
2 ingressi digitali ausiliari / <i>2 auxiliary digital inputs</i>	■	#
1 relè segnalazione allarmi / <i>Alarm output relays</i>	■	■

uno impegnato dal reset / *one comitted by reset*



Manuale



User manual

Per approfondimenti si raccomanda di scaricare il manuale d'uso dal nostro sito www.transtecno.com alla pagina dei prodotti.

Please, download the user manual for more information from our web site www.transtecno.com from the product page.

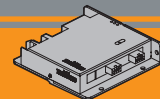

GUIDA alla selezione dell'azionamento

Drive selection GUIDE

Corrente di uso del motore \leq Corrente nominale dell'azionamento

Real motor current \leq Rated current of the drive

Attenzione: la reale corrente assorbita dal motore può essere diversa da quella indicata in targhetta.

PLN19-8 = max 6 A

PLN20 = max 22 A

PLN40 = max 44 A

Vedere sotto la tabella per esemplificazioni

Warning: the real absorbed current by the motor can be different from the one written on the nameplate.

PLN19-8 = max 6 A

PLN20 = max 22 A

PLN40 = max 44 A

See the table below for quick reference

Codice motore Motor code	Corrente motore Motor current S1	Scheda-Drive (servizio motore-motor duty) S1	Corrente motore Motor current S2	Scheda-Drive (servizio motore-motor duty) S2
EC020.120	3.2	PLN19-8 – PLN20	4	PLN19-8 – PLN20
EC020.240	1.5	PLN19-8 – PLN20	2	PLN19-8 - PLN20
EC035.120	5.2	PLN19-8 – PLN20	8	PLN20
EC035.240	2.6	PLN19-8 - PLN20	4	PLN19-8 - PLN20
EC050.120	6.8	PLN20	9.4	PLN20
EC050.240	3.4	PLN19-8 - PLN20	4.7	PLN19-8 - PLN20
EC070.120	8.4	PLN20	11.8	PLN20
EC070.240	4.2	PLN19-8 - PLN20	5.9	PLN19-8 - PLN20
EC100.120	12	PLN20	16.8	PLN20
EC100.240	6	PLN19-8 - PLN20	8.4	PLN20
EC100.24E	6	PLN19-8 - PLN20	8.4	PLN20
ND100.120	13.9	PLN20	19	PLN20
ND100.240	6.9	PLN20	9.0	PLN20
EC180.120	21.5	PLN20	30	PLN40
EC180.240	10.8	PLN20	15	PLN20
EC180.24E	10.8	PLN20	15	PLN20
ND180.120	20	PLN20	30	PLN40
ND180.240	10	PLN20	14	PLN20
EC250.120	30	PLN40	39	PLN40
EC250.240	15	PLN20	19.5	PLN20
EC350.240	21	PLN20	29.4	PLN40
EC350.240BR				
EC600.240	35.5	PLN40	47	PLN40
EC600.240BR				

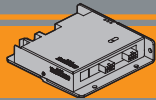

Note/Notes

**TRANSTECNO SRL
HEADQUARTERS**

Company subject to the management
and coordination of INTERPUMP GROUP SPA
Via Caduti di Sabbiuno, 11/D-E
40011 Anzola dell'Emilia (BO)
ITALY
T+39 051 64 25 811
F +39 051 73 49 43
sales@transtecno.com
www.transtecno.com

TRANSTECNO®
the modular gearmotor
MEMBER OF INTERPUMP GROUP

CATDCALU0521



**HANGZHOU TRANSTECNO POWER
TRANSMISSIONS CO LTD**
No.4 Xiuyan Road Fengdu Industry Zone
Pingyao Town Yuhang District
Hangzhou City, Zhejiang Province
311115 – CHINA
T +86 571 86 92 02 60
F +86 571 86 92 18 10
info-china@transtecno.cn
www.transtecno.cn

MA TRANSTECNO S.A.P.I. DE C.V.
Av. Mundial # 176, Parque Industrial
JM Apodaca, Nuevo León,
C.P. 66600 – MÉXICO
T +52 8113340920
info@transtecno.com.mx
www.transtecno.com.mx

**TRANSTECNO IBÉRICA
THE MODULAR GEARMOTOR, S.A.**
Carrer de la Ciència, 45
08840 Viladecans (Barcelona) – SPAIN
T +34 931 598 950
info@transtecno.es
www.transtecno.es

TRANSTECNO B.V.
De Stuwdam, 43
3815 KM Amersfoort – NETHERLANDS
T +31(0) 33 45 19 505
F +31(0) 33 45 19 506
info@transtecno.nl
www.transtecno.nl

www.transtecno.com

TRANSTECNO AANDRIJFTECHNIEK B.V.
De Stuwdam 43
3815 KM Amersfoort – NETHERLANDS
T +31 (0) 33 20 4 7 006
info@transtecnoaandrijftechniek.nl
www.transtecnoaandrijftechniek.nl

TRANSTECNO USA
8 Creek Parkway,
Boothwyn PA 19061-8136
UNITED STATES
T +1 (610) 4970154
F +1 (610) 497 6085

14561 Fryelands Blvd SE
Monroe, WA 98272 - UNITED STATES
T +1 360-863-1300
F +1 360-863-1303
usaoffice@transtecno.com
www.transtecno.com

TRANSTECNO CANADA
51 B Caldari Road Unit 10
Vaughan, ON L4K 4G3 - CANADA
T +1 905 761 0762
F +1 905 761 9265
canadaoffice@transtecno.com
www.transtecno.com

TRANSTECNO CHILE-PERU
Av. Los Libertadores 41
Parque Industrial - Los Libertadores 16.500
Santiago, Colina - CHILE
T +56 2 29633870

Carretera Panamericana Sur KM 29.5,
Interior I-3, Z.I. Lurin - PERU
T +51 1 3546259 / + 51 1 3434231
chileoffice@transtecno.com
www.transtecno.com

SALES OFFICE BRAZIL
Rua Dr. Freire Alemão 155 / 402 - CEP. 90450-060
Auxiliadora Porto Alegre RS - BRAZIL
T +55 51 3251 5447
F +55 51 3251 5447
M +55 51 811 45 962
braziloffice@transtecno.com
www.transtecno.com.br

SALES OFFICE OCEANIA
44 Northview drive, Sunshine west 3020
Victoria - AUSTRALIA
T +61 03 9312 4722
F +61 03 9312 4714
M +61 0438060997
oceaniaoffice@transtecno.com
www.transtecno.com.au

SALES OFFICE INDIA
Woodbine 2003/04, Everest World
Kolshet Road, Thane west Mumbai 400607
INDIA
T +91 982 061 46 98
indiaoffice@transtecno.com
www.transtecno.com

SALES OFFICE SOUTH KOREA
772-41, Bongdong-ro, Bongdong-eup, Wanju-goon
Chonbuk, 55313
SOUTH KOREA
T +82 70 8867 8897
F +82 504 199 2107
M +82 10 5094 2107
koreaoffice@transtecno.com
www.transtecno.com