



# Service manual

## Optical encoder ME 22



### Index

	Pag.
Description	2
Features	2
Ordering information	2
Recommended operating conditions	3
Absolute maximum ratings	3
Dimensions	4
Electrical interface	4
Mechanical notes	5
Mounting considerations	5
ME22 mounting instructions	6
Available accessories	8



#### MANUFACTURER INFORMATION

THIS DOCUMENT AND ANY ASSOCIATED DATA CONTAIN RESTRICTED INFORMATION THAT IS PROPERTY OF THE MANUFACTURER AND MAY NOT BE DISCLOSED OR DUPLICATED FOR OTHERS EXCEPT AS AUTHORIZED BY THE MANUFACTURER. INFORMATION CONTAINED IN THIS PUBLICATION MAY BE SUPERSEDED BY UPDATES. IT IS YOUR RESPONSIBILITY TO ENSURE THAT YOUR APPLICATION MEETS WITH YOUR SPECIFICATIONS.



## Description

The ME22 is a reliable low cost optical hollow shaft encoder that can be fixed quickly and easily on different sizes of motor shafts.

The encoder provides two square wave outputs in quadrature (90 degrees phase shifted) for counting and direction information. The revolution of the encoder is determined by the number of counts per revolution (CPR).

Power supply and signals are provided by a 5 pin Molex connector.

## Features

- Small size: 22 mm diameter x 21.9 mm length.
- Quick and easy assembly without touching sensitive components
- Output channels: 2 in quadrature
- Power supply: 5 VDC
- Output type: TTL compatible
- Output circuit: pull-up
- Resolution up to 360 CPR (counts per revolution)
- Maximum shaft diameter: 9.525 mm (3/8)
- Operating temperature: -20 °C to 85 °C
- Frequency: 60 kHz
- Compliant EU-directive 2002/95/EG (RoHS)

## Ordering information

ME22	100	6.000	2	LS
	Encoder Resolution (CPR)*	Motor shaft diameter (mm)	Number of channels	Output option
	001 **	1.500	1 = 1 Canale	LS = connector + standar cable
	002 **	2.000	2 = 2 Canali	
	004 **	2.300		
	008 **	2.500		
	050 ***	3.000		
	064 ***	3.175 (1/8")		
	100	3.969 (5/32")		
	108	4.000		
	120	4.763 (3/16")		
	124	5.000		
	128	6.000		
	150	6.350 (1/4")		
	160	8.000		
	200	9.000		
	250	9.525 (3/8")		
	256			
	300			
	360			

\*: other encoder resolutions on request

\*\* : only two channel

\*\*\*: only one channel

 Preferential codes

**Available accessories**, see page 8

- cable 300 mm length (UL1061 / AWG28)
- centering gauge (not included as standard part)
- fastening screws DIN 84 M1.6x3



### Recommended operating conditions

Electrical characteristics are only effective for the range of the operating temperatures.  
Standard values at 25 °C and  $V_{DC} = 5 V$ .

Parameter	Symbol	Min.	Standard	Max.	Unit	Notes
Operating temperature	$T_A$	+25	- 20	+85	° C	
Supply voltage	$V_{DC}$	5.0	4.5	5.5	$V_{CC}$	
Supply current (two channels)	$I_{CC}$	15	13	18	mA	
Load capacitance	$C_L$			100	pF	internal pull-up 2.7 k $\Omega$
Count frequency	f			60	kHz	rpm x N / 60 x 10 <sup>-3</sup>
<b>A &amp; B Channel</b>						
High level output voltage	$V_{OH}$		2.4		$V_{CC}$	$I_{OH} = -0.2$ mA
Low level output voltage	$V_{OL}$			0.4	$V_{CC}$	$I_{OL} = 8$ mA
Rise time	$T_r$	500/(7)*			ns /( $\mu$ s)*	$C_L = 25$ pF
Fall time	$T_f$	100/(1.3)*			ns /( $\mu$ s)*	$R_L = 2.7$ k $\Omega$

\* only for 1, 2, 4, 8 CPR variant

### Absolute maximum ratings

Parameter	Symbol	Min.	Max.	Unit	Notes
Storage temperature	$T_S$	- 40	+ 85	° C	
Operating temperature	$T_A$	- 20	+ 85	$V_{CC}$	
Humidity exposure			90	% RH	not condensing
Supply voltage	$V_{CC}$	- 0.5	7	$V_{CC}$	
Output voltage	$V_O$	- 0.5		$V_{CC}$	
Output current per channel	$I_{OUT}$	- 1.0	8	mA	
Vibration			2000	Hz	20 g

#### ATTENTION

#### ESD Warning:

Normal handling precautions should be taken to avoid static discharge damage to the sensor.

## Dimensions

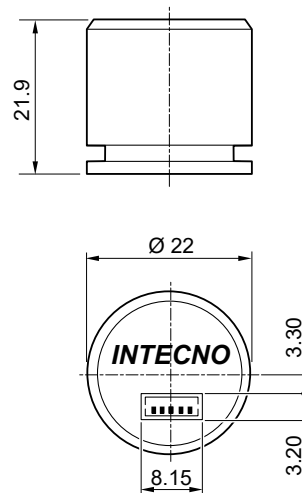

## Electrical interface

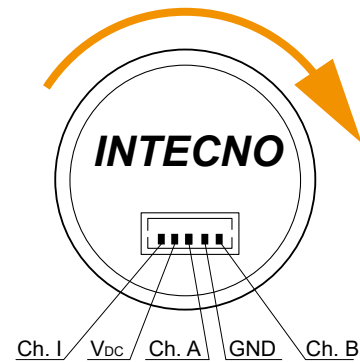
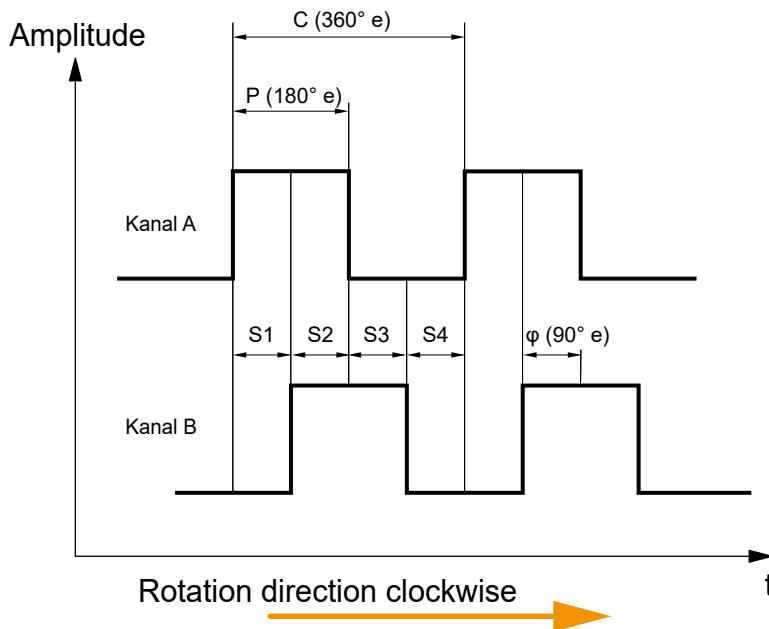

### Definitions:

- **CPR** - Counts per Revolution: The number of bar and window pairs or increments per revolution of the code wheel.
- **C** - One cycle: 360 electrical degrees ( $^{\circ}e$ ), one period of the signal, caused by one pair of bar and window.
- **P** - Pulse Width: The number of electrical degrees that an output is high during one cycle. This value is nominally  $180^{\circ}e$ .
- **S** - State Width: The number of electrical degrees between a transition in the output of channel A and the neighbouring transition in the output of channel B. There are 4 states per cycle, each nominally  $90^{\circ}e$ .
- **$\phi$**  - Phase: The number of electrical degrees between the centre of the high state of channel A and the center of the high state of channel B. This value is nominally  $90^{\circ}e$ .
- **$\Delta Q$**  - Position error: The angular difference between the actual angular shaft position and the position indicated by the encoder cycle count.

### Encoding characteristics channel A & B:

Parameter	Symbol	Nominal	Max. Error	Unit
Pulse width	P	180	$\pm 70$	$^{\circ}e$
Phase shift	$\phi$	90	$\pm 60$	$^{\circ}e$

## Mechanical Notes



Parameter	Symbol	Value	Tolerance	Unit
Outer dimensions		Ø 22,0 x 21,9	-	mm
Shaft diameter	Øw	1,5 / 2,0 / 2,3 / 2,5 / 3,0 / 3,175 / 3,969 / 4,0 4,763 / 5,0 / 6,0 / 6,35 / 8,0 / 9,0 / 9,525	± 0.01	mm
Required shaft length	Lw	9,5	+ 2.0	mm
Max. allowable axial shaft play of motor		0,6	-	mm
Max. allowable radial shaft play of motor		0,025	-	mm
Mounting screw size (DIN 84)		M1.6	-	-
Tightening torque of the screws		15	- 5	Ncm
Pitch circle diameter	Øc	17,0	± 1.0	mm
Flange inside bore diameter	Øz	7,1 o 10,1	+ 0.03	mm
Mounting boss diameter	Øm	7,1	- 0.03	mm
Max. mounting boss height	hz	1,5	- 0.1	mm
Mating connector (Molex)		5 pin 50079-8000 housing 51021-0500	-	
Total weight		7	-	g
Moment of inertia of the hub with the code wheel		5,2	± 1.0	g·mm <sup>2</sup>
Protection grade according to DIN 40500		IP50	-	-

## Mounting considerations

The ME22 encoder is designed to self align by using a mounting boss. **You need a tool centering gauge.** The drawing shows the configuration of the mounting boss along with the location of the mounting screw holes. Shaft diameter and tolerances are given in the above mentioned chart.

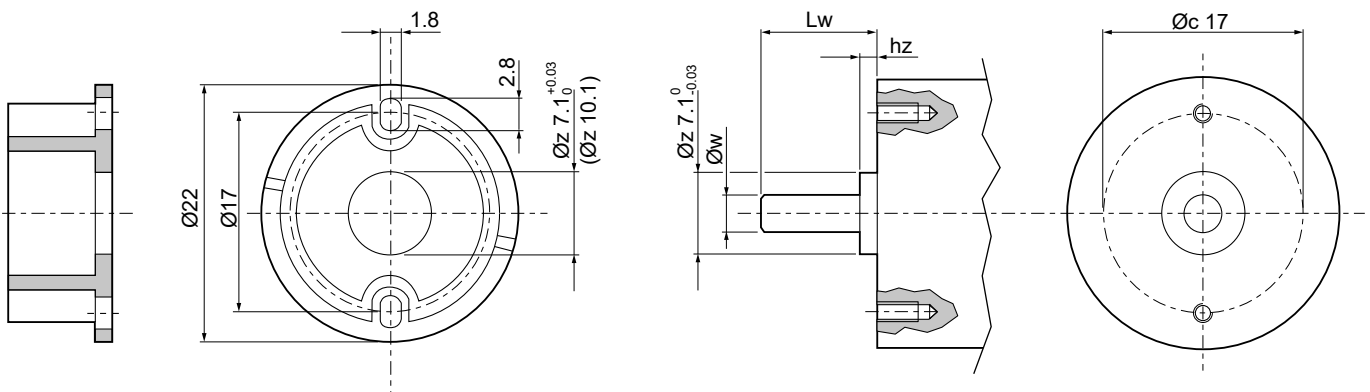



1

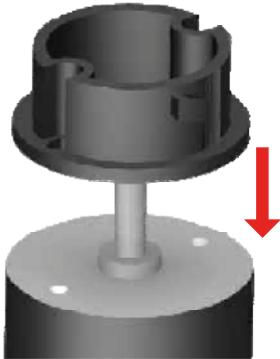

Align the base plate to the motor shaft by using the centering gauge

2

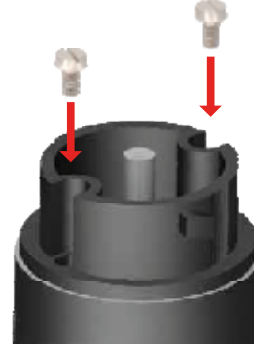

Afterwards fix the base plate to the motor flange using two screws

3



Align the housing to the base plate, slide the housing onto the base plate

4



and the hub centers itself on the motor shaft

5



From this position the housing cannot be locked

6



Press the housing into the final position

## ME22 mounting instructions



7



Now the housing can be locked

8



Turn the housing into its final position, the encoder is now ready for use

## WARNING



**DO NOT ROTATE AND PULL OUT THE ENCODER AFTER ASSEMBLY OR WHEN IT IS IN OPERATION.**

### ATTENTION

The encoder is designed that it may be assembled only one time, otherwise the guarantee will be voided. Note: see IMPORTANT NOTICE (page 8)

## Available accessories



- Standard cable length 300 mm (UL 1061 / AWG 28)

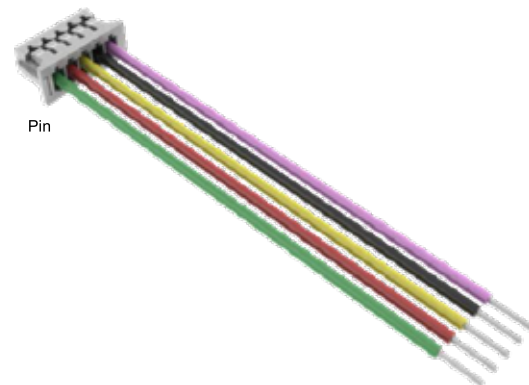

- Centering gauge for centering the ME base plate on the motor flange or an adapter plate



- Screws DIN84 M1.6 X 3



## IMPORTANT NOTICE

The encoder is designed that it may be assembled only one time, otherwise the guarantee will be voided. The guarantee will be voided by misuse, accident, modification, unsuitable physical or operating environment, operation in other than the specified operating environment, or failure caused by a product for which the manufacturer is not responsible.

The manufacturer reserves the right to make corrections, modifications, enhancements, improvements, and other changes to its products and services also datasheets at any time.